

GLOBAL JOURNAL

OF MEDICAL RESEARCH: I

Surgeries and Cardiovascular System



Chest Wall Reconstruction

Massive Hemothorax Following

Highlights

Impact of the use of Probiotics

Strategies in Ballistics Reconstruction

Discovering Thoughts, Inventing Future

VOLUME 24

ISSUE 1

VERSION 1.0



GLOBAL JOURNAL OF MEDICAL RESEARCH: I
SURGERIES AND CARDIOVASCULAR SYSTEM



GLOBAL JOURNAL OF MEDICAL RESEARCH: I
SURGERIES AND CARDIOVASCULAR SYSTEM

VOLUME 24 ISSUE 1 (VER. 1.0)

OPEN ASSOCIATION OF RESEARCH SOCIETY

© Global Journal of Medical Research. 2024.

All rights reserved.

This is a special issue published in version 1.0 of "Global Journal of Medical Research." By Global Journals Inc.

All articles are open access articles distributed under "Global Journal of Medical Research"

Reading License, which permits restricted use. Entire contents are copyright by of "Global Journal of Medical Research" unless otherwise noted on specific articles.

No part of this publication may be reproduced or transmitted in any form or by any means, electronic or mechanical, including photocopy, recording, or any information storage and retrieval system, without written permission.

The opinions and statements made in this book are those of the authors concerned. Ultraculture has not verified and neither confirms nor denies any of the foregoing and no warranty or fitness is implied.

Engage with the contents herein at your own risk.

The use of this journal, and the terms and conditions for our providing information, is governed by our Disclaimer, Terms and Conditions and Privacy Policy given on our website <http://globaljournals.us/terms-and-condition/menu-id-1463/>

By referring / using / reading / any type of association / referencing this journal, this signifies and you acknowledge that you have read them and that you accept and will be bound by the terms thereof.

All information, journals, this journal, activities undertaken, materials, services and our website, terms and conditions, privacy policy, and this journal is subject to change anytime without any prior notice.

Incorporation No.: 0423089
License No.: 42125/022010/1186
Registration No.: 430374
Import-Export Code: 1109007027
Employer Identification Number (EIN):
USA Tax ID: 98-0673427

Global Journals Inc.

(A Delaware USA Incorporation with "Good Standing"; **Reg. Number: 0423089**)

Sponsors: *Open Association of Research Society*

Open Scientific Standards

Publisher's Headquarters office

Global Journals® Headquarters
945th Concord Streets,
Framingham Massachusetts Pin: 01701,
United States of America

USA Toll Free: +001-888-839-7392

USA Toll Free Fax: +001-888-839-7392

Offset Typesetting

Global Journals Incorporated
2nd, Lansdowne, Lansdowne Rd., Croydon-Surrey,
Pin: CR9 2ER, United Kingdom

Packaging & Continental Dispatching

Global Journals Pvt Ltd
E-3130 Sudama Nagar, Near Gopur Square,
Indore, M.P., Pin:452009, India

Find a correspondence nodal officer near you

To find nodal officer of your country, please
email us at local@globaljournals.org

eContacts

Press Inquiries: press@globaljournals.org
Investor Inquiries: investors@globaljournals.org
Technical Support: technology@globaljournals.org
Media & Releases: media@globaljournals.org

Pricing (Excluding Air Parcel Charges):

Yearly Subscription (Personal & Institutional)
250 USD (B/W) & 350 USD (Color)

EDITORIAL BOARD

GLOBAL JOURNAL OF MEDICAL RESEARCH

Dr. Apostolos Ch. Zarros

DM, Degree (Ptychio) holder in Medicine,
National and Kapodistrian University of Athens
MRes, Master of Research in Molecular Functions in
Disease, University of Glasgow FRNS, Fellow, Royal
Numismatic Society Member, European Society for
Neurochemistry Member, Royal Institute of Philosophy
Scotland, United Kingdom

Dr. Alfio Ferlito

Professor Department of Surgical Sciences
University of Udine School of Medicine, Italy

Dr. Jixin Zhong

Department of Medicine, Affiliated Hospital of
Guangdong Medical College, Zhanjiang, China, Davis
Heart and Lung Research Institute, The Ohio State
University, Columbus, OH 43210, US

Rama Rao Ganga

MBBS
MS (University of Health Sciences, Vijayawada, India)
MRCS (Royal College of Surgeons of Edinburgh, UK)
United States

Dr. Izzet Yavuz

MSc, Ph.D., D Ped Dent.
Associate Professor, Pediatric Dentistry Faculty of
Dentistry, University of Dicle Diyarbakir, Turkey

Sanguansak Rerksuppaphol

Department of Pediatrics Faculty of Medicine
Srinakharinwirot University
NakornNayok, Thailand

Dr. William Chi-shing Cho

Ph.D.,
Department of Clinical Oncology
Queen Elizabeth Hospital
Hong Kong

Dr. Michael Wink

Ph.D., Technical University Braunschweig, Germany
Head of Department Institute of Pharmacy and Molecular
Biotechnology, Heidelberg University, Germany

Dr. Pejic Ana

Assistant Medical Faculty Department of Periodontology
and Oral Medicine University of Nis, Serbia

Dr. Ivandro Soares Monteiro

M.Sc., Ph.D. in Psychology Clinic, Professor University of
Minho, Portugal

Dr. Sanjay Dixit, M.D.

Director, EP Laboratories, Philadelphia VA Medical Center
Cardiovascular Medicine - Cardiac Arrhythmia
Univ of Penn School of Medicine
Web: pennmedicine.org/wagform/MainPage.aspx?

Antonio Simone Laganà

M.D. Unit of Gynecology and Obstetrics
Department of Human Pathology in Adulthood and
Childhood "G. Barresi" University of Messina, Italy

Dr. Han-Xiang Deng

MD., Ph.D
Associate Professor and Research Department
Division of Neuromuscular Medicine
Davee Department of Neurology and Clinical
Neurosciences
Northwestern University Feinberg School of Medicine
Web: neurology.northwestern.edu/faculty/deng.html

Dr. Roberto Sanchez

Associate Professor
Department of Structural and Chemical Biology
Mount Sinai School of Medicine
Ph.D., The Rockefeller University
Web: mountsinai.org/

Dr. Feng Feng

Boston University
Microbiology
72 East Concord Street R702
Duke University
United States of America

Dr. Hrushikesh Aphale

MDS- Orthodontics and Dentofacial Orthopedics.
Fellow- World Federation of Orthodontist, USA.

Gaurav Singhal

Master of Tropical Veterinary Sciences, currently
pursuing Ph.D in Medicine

Dr. Pina C. Sanelli

Associate Professor of Radiology
Associate Professor of Public Health
Weill Cornell Medical College
Associate Attending Radiologist
NewYork-Presbyterian Hospital
MRI, MRA, CT, and CTA
Neuroradiology and Diagnostic Radiology
M.D., State University of New York at Buffalo,
School of Medicine and Biomedical Sciences
Web: weillcornell.org/pinasanelli/

Dr. Michael R. Rudnick

M.D., FACP
Associate Professor of Medicine
Chief, Renal Electrolyte and Hypertension Division (PMC)
Penn Medicine, University of Pennsylvania
Presbyterian Medical Center, Philadelphia
Nephrology and Internal Medicine
Certified by the American Board of Internal Medicine
Web: uphs.upenn.edu/

Dr. Seung-Yup Ku

M.D., Ph.D., Seoul National University Medical College,
Seoul, Korea Department of Obstetrics and Gynecology
Seoul National University Hospital, Seoul, Korea

Santhosh Kumar

Reader, Department of Periodontology,
Manipal University, Manipal

Dr. Aarti Garg

Bachelor of Dental Surgery (B.D.S.) M.D.S. in Pedodontics
and Preventive Dentistr Pursuing Phd in Dentistry

Sabreena Safuan

Ph.D (Pathology) MSc (Molecular Pathology and Toxicology) BSc (Biomedicine)

Getahun Asebe

Veterinary medicine, Infectious diseases, Veterinary Public health, Animal Science

Dr. Suraj Agarwal

Bachelor of dental Surgery Master of dental Surgery in Oromaxillofacial Radiology.
Diploma in Forensic Science & Oodontology

Osama Alali

PhD in Orthodontics, Department of Orthodontics, School of Dentistry, University of Damascus. Damascus, Syria. 2013 Masters Degree in Orthodontics.

Prabudh Goel

MCh (Pediatric Surgery, Gold Medalist), FISPU, FICS-IS

Raouf Hajji

MD, Specialty Assistant Professor in Internal Medicine

Surekha Damineni

Ph.D with Post Doctoral in Cancer Genetics

Arundhati Biswas

MBBS, MS (General Surgery), FCPS, MCh, DNB (Neurosurgery)

Rui Pedro Pereira de Almeida

Ph.D Student in Health Sciences program, MSc in Quality Management in Healthcare Facilities

Dr. Sunanda Sharma

B.V.Sc.& AH, M.V.Sc (Animal Reproduction, Obstetrics & gynaecology),
Ph.D.(Animal Reproduction, Obstetrics & gynaecology)

Shahanawaz SD

Master of Physiotherapy in Neurology PhD- Pursuing in Neuro Physiotherapy Master of Physiotherapy in Hospital Management

Dr. Shabana Naz Shah

PhD. in Pharmaceutical Chemistry

Vaishnavi V.K Vedam

Master of dental surgery oral pathology

Tariq Aziz

PhD Biotechnology in Progress

CONTENTS OF THE ISSUE

- i. Copyright Notice
 - ii. Editorial Board Members
 - iii. Chief Author and Dean
 - iv. Contents of the Issue
-
1. Strategies in Ballistics Reconstruction in Shooting Deaths: Checklist, Methods, Tricks, and Pitfalls. *1-7*
 2. Technologies that will Transform Healthcare. *9-20*
 3. Impact of the use of Probiotics in Bariatric Patients in Promoting Weight Loss and Maintenance. A Systematic Review. *21-26*
 4. Chest Wall Reconstruction with Expanded Polytetrafluoroethylene Mesh in Pediatric Patient. Chest Wall Reconstruction with Mesh. *27-29*
 5. Massive Haemo Thorax Following Ultrasound-Guided Central Venous Catheterization in an Anaesthetised Patient: A Case Report. *31-34*
-
- v. Fellows
 - vi. Auxiliary Memberships
 - vii. Preferred Author Guidelines
 - viii. Index



GLOBAL JOURNAL OF MEDICAL RESEARCH: I
SURGERIES AND CARDIOVASCULAR SYSTEM
Volume 24 Issue 1 Version 1.0 Year 2024
Type: Double Blind Peer Reviewed International Research Journal
Publisher: Global Journals
Online ISSN: 2249-4618 & Print ISSN: 0975-5888

Strategies in Ballistics Reconstruction in Shooting Deaths: Checklist, Methods, Tricks, and Pitfalls

By De Luca Benedetta Pia, Francesco Vinci & Maricla Marrone

University of Bari Aldo Moro

Abstract- Background: The multidisciplinary type of Forensic Ballistics science is an essential database for the medical examiner to define the most compatible sequence of events and to motivate reconstructive hypotheses. In gunshot victims, analysis of biological data alone may be insufficient for recon-structive purposes. Knowledge of the basic general principles relating to mechanisms, indicators, operating systems, power supplies, types of bullets, and so on, can make the difference between a "sterile" autopsy and one that can be useful to judicial investigations.

Results: The reconstruction of the event, the final phase of criminal investigation, must include the interpretation and re-composition of the various elements of evidence and the overall evaluation of the same to obtain a legal characterization.

Keywords: *firearm, ballistic, medical examiner, forensic science.*

GJMR-I Classification: *NLMC Code: QY630*



Strictly as per the compliance and regulations of:



Strategies in Ballistics Reconstruction in Shooting Deaths: Checklist, Methods, Tricks, and Pitfalls

De Luca Benedetta Pia ^α, Francesco Vinci ^σ & Maricla Marrone ^ρ

Abstract- Background: The multidisciplinary type of Forensic Ballistics science is an essential database for the medical examiner to define the most compatible sequence of events and to motivate reconstructive hypotheses. In gunshot victims, analysis of biological data alone may be insufficient for reconstructive purposes. Knowledge of the basic general principles relating to mechanisms, indicators, operating systems, power supplies, types of bullets, and so on, can make the difference between a "sterile" autopsy and one that can be useful to judicial investigations.

Results: The reconstruction of the event, the final phase of criminal investigation, must include the interpretation and re-composition of the various elements of evidence and the overall evaluation of the same to obtain a legal characterization. Therefore it can be very difficult to express a scientifically valid and sufficiently motivated opinion on important issues relating to the immediacy or otherwise of death, the duration of survival, the possibility of residue acts committed by the victim after the injury, or autonomous movements or other acts conscious such as invocations for help, recognition of persons, report of lived events. The less early the investigator's intervention at the crime scene, the more difficult it will be to collect data and evidence correctly.

Conclusion: With this manuscript, the authors want to provide useful elements so that the medical examiner can integrate his knowledge and provide valid answers to the questions posed by the judge.

Keywords: firearm, ballistic, medical examiner, forensic science.

I. INTRODUCTION

The multidisciplinary type of forensic ballistic science and the intrinsic difficulty of evaluating the plurality of related investigations, of correlating and integrating the findings acquired during the various speculative phases, constitute an indispensable database for the medical examiner. These are used to define the most compatible sequence of events and to motivate reconstructive hypotheses, scientifically correct and therefore concretely used in the juridical context for the definition of responsibilities, to confirm or refute specific accusatory and/or defensive assumption juridical, and to obtain an adequate punishment [1] [2] [3] [4].

In gunshot victims, the analysis of biological data alone may be insufficient for reconstructive purposes, especially when an event has a strong emotional impact,

Author α σ ρ: Section of Legal Medicine, Interdisciplinary Department of Medicine, University of Bari "Aldo Moro", 70124 Bari, Italy.
e-mails: benedettapia.deluca@gmail.com (B.P.D.L.); mariclamarrone@hotmail.it (M.M.); alfabano@gmail.com (F.V.)

is of strong national importance, and is therefore subject to different interpretations not always strictly correlated with objective evidence [5] [6].

Knowledge of basic general principles regarding mechanisms, indicators, operating systems, power, types of bullet, and so on, can make the difference between a "sterile" autopsy and one that can be useful for judicial investigations [7].

An autopsy in this field, conducted without having any idea of how a firearm is made, especially in the presence of a large number of shots, and ignoring what damage can be produced based on various factors (caliber, type of ammunition, polygon, and much more), in our opinion it is like walking through a labyrinth on a moonless night and certainly does not meet the judge's needs to clarify the various aspects of judicial case [8] [9].

II. MATERIALS AND METHODS

The reconstruction of the events during which a firearm is a problem that escapes the exclusive pathological study of ballistic agent injuries and requires an integrated assessment by other criminological investigations, whose practical relevance in the legal field and the intrinsic difficulty of the interaction of the plurality of correlated investigations, suggests a constant scientific, cultural and methodological exchange between various disciplines (chemistry, physics, mechanics, engineering, economics of goods, information technology, etc...), sometimes different from each other for purposes and procedures, the coordination of which recognizes in the figure of the medical examiner a role of enlargement and synthesis of undoubted value [10] [11].

The reconstruction of the event, the final phase of criminal investigation, must include the interpretation and re-composition of the various elements of evidence and the overall evaluation of the same to obtain a legal characterization; In other words, the effort to determine, on the basis on the available data, the various phases of a criminal episode and how much more reliable and chronologically they are [10] [11] [12].

In particular, the immediate effects on the behavior of a person hit by a firearm bullet are predictable (therefore partially) only with the knowledge of the type of weapon used, the firing distance, and the anatomical region concerned. The individual factors that can lead to wide variations of the "perception" of the lesion must be kept in mind; as well as in the case of people subjected

to strong physical and mental stress or in a state of adrenaline stimulation, which can decrease it or in particular cases even abolish it, or, on the contrary, in severe states of fatigue and weakness or poor physical conditions efficiency that can significantly amplify [11] [13].

Therefore, it can be very difficult to express a scientifically valid and sufficiently motivated opinion on important issues relating to the immediacy or otherwise of death, the duration of survival, the possibility of residual acts committed by the victim after the injury, or autonomous movements or other acts conscious such as involocations for help, recognition of persons, report of lived events. Circumstantial and testimonial data are often not available or, when available, they must in any case be supported by other objective factors that demonstrate or evaluate their reliability [11] [12] [13] [14].

So, for each of the following cases, it is necessary to combine all findings to be able to put forward a truthful reconstructive hypothesis. In particular, the medical examiner must consider the autopsy findings and all other circumstantial data to be able to make a differential diagnosis between the following situations [15] [16]:

- Suicide with more than one stroke [14];
- Homicide-suicide or double suicide;
- Injury with the victim's reaction;
- Injury followed by conscious movements or acts;
- Death followed by missed or delayed aid.

There are particularly complex cases. For example, a suicide could shoot himself multiple times to kill himself: this could happen in cases where the first shot was not fatal. Or again there are cases in which the victim, after being shot may make conscious movements or acts, such as even returning gunfire. Finally, the victim may die not from the gunshot injury, but from a delay in rescue. For example, this may occur in cases where the bullet does not hit a "vital" site but causes a loss of blood that, if treated promptly by rescue, may not prove lethal.

III. RESULTS

The less early the investigator's at the crime scene, the more difficult it will be to collect data and evidence correctly; in other cases, the autopsies are supported by elements already acquired, not always sufficiently documented, and most of the time not verifiable both for the long interval of time that often elapses from the events under investigation and for profound changes in the characteristics of some elements, such as to preclude the repeatability of some investigations. In any case, all evidence should be available to the medical examiner. The same performs the autopsy and combines the autopsy findings with all other evidence to arrive at the reconstruction of the crime. [17].

It must be considered, however, that the forensic scientist must have an overall view. Considering only one

piece of evidence could be misleading. Nothing should ever be taken for granted. For example, the finding of shell casings and bullets at the crime scene is not sufficient to answer the question of the location of the findings. A shell casing or bullet may have been moved from one place to another intentionally or occasionally: they may be "trapped" in the victim's body or in a vehicle that may have been moved from their original location. Or, they could have been accidentally moved by being kicked by passersby, due to their circular shape.

Crucially important indications in this regard come from the correlation of the findings (cartridges and bullets) with any defects in the environment (walls, furniture, vehicles, etc.) that could be impact points.

Moreover, the caliber of the spent cartridges found at the crime scene is not sufficient to make a judgment of certainty about the type of weapon used to kill the victim. Only the ballistic investigations carried out on the bullet found inside the victim's body make it possible to express a definite opinion on the caliber used to kill the victim. Therefore, one must wait for the results of the laboratory ballistic investigations carried out on the bullets found during the autopsy inside the victim's body. In addition, revolvers do not leave cartridge cases as the spent cartridge cases remain inside the drum: cartridge cases may explode from a revolver and can be found only if the shooter unloaded the gun by hand by removing the spent cartridge cases.

The number of weapons used during shooting is possible only after Comparative Ballistics investigations are carried out on bullets and shell casings.

In addition, the presence of blood traces at the crime scene must be carefully and adequately evaluated, from the point of view of quantity, morphology, and location. The possibility that the victim's body moved or made autonomous movements, even after being hit by one or more bullets, must always be considered [13] [18]. It should also be considered that the victim's body may have moved after being shot.

A reliable chronological diagnosis on the dating of the shooting is only possible through examination and interpretation of the data collected on the corpse. Any other inference, for example, based on the degree of oxidation of shell casings or bullet defects, is purely arbitrary and inaccurate. Very old and oxidized ammunition can be efficient even after more than 50 years. We observed a case in which an old French revolver built in 1870 and using pin cartridges was able to easily cause fatal wounds [11].

Finally, the determination of firing points and trajectories is only possible if the exact location and characteristics of the impact points in the environment and the position of the cartridge cases on the ground are known.

IV. DISCUSSION

a) Autopsy Strategies

- Even in particularly striking cases, postpone any judgment regarding the cause of death to the autopsy; existing natural disease, anatomical damage, functional impairment, viability of each lesion, interaction with other possible natural pathologies, and associated bleeding, must be appropriately assessed [11].
- Verify the adequacy of the position of the corpse at the crime scene with the arrangement of the hypostases and the attitude posed by the rigor mortis, to establish the place where the death occurred;
- The type of weapon (or weapons) and its caliber must be recognized based on the interpretation of the data emerging from the autopsy; the analysis of the morphology and extent of skin lesions is usually sufficient to express only a general judgment on the type of ammunition (whether single or multiple bullets); more difficult, and often impossible, is the definition of the caliber [13];
- *single bullet* if no bullets were found during the autopsy, the dimension of the perforations of the flat bones (skull, scapula, iliac bones, etc.), which allow an orientation, with good approximation, can be of help on the diameter of the bullet that produced them. However, alongside the cases of simpler interpretation (subject hit by one or more bullets and then recovered during autopsy), it is not uncommon to have injuries caused by several bullets, all or part, not retained in the body. In this case, it is not possible to specify whether the injuries observed were produced by bullets of the same caliber and therefore whether they were fired from a single weapon; therefore the final evaluation should be based on a judgment of compatibility between the findings made during the autopsy and what is provided by the inspection, by historical and circumstantial data and above all by comparative findings on any material found during the inspection [19] [11];
- *Weapons with Multiple Bullets (Rifles)*
 - o The evaluation of the caliber is possible with certainty only with the finding of the wad during the autopsy.
 - o The evaluation starting from the pellet (weight - number of pellets - charge ratio on the pressure gauge) is considered too approximate, while it can be more reliable in the case of pellets, provided that all the components of the charge have been recovered:
- Some shots
- Single bullets

Apply the formula $N = E + R$ (Number of shots = exit wounds + recovered bullets), but consider the following possibilities:

- Bullets, usually two, entered through a single entry hole;
- Intracorporeal fragmentation of the bullet;
- More body regions are hit by the same bullet.

The last of the reported facts concerns particular positions of the victim at the time of the injury, which would justify more injuries than that of shots fired, regarding the possibility of multiple injuries produced by the same bullet (for example a bullet first hits a limb and then the trunk, or vice versa); in these cases, at the end of the autopsy, it will be possible to document the alignment possibilities of the different lesions with the use of rods (preferably metal, max diameter 5 mm, with rounded tips), highlighting the compatibility with particular positions of the limbs or trunk [20].

- Multiple rates
- Over very short distances the "ball" effect can make possible injuries in different anatomical sites (one of which is usually represented by a limb), like what is done by single bullets; this possibility must be verified using suitable positioning maneuvers.
- For shots fired at a distance that does not allow recovery of the wads, the definition of the number of shots can be cumbersome. It may be possible, depending on the case, to consider whether the saturation of a body surface by a given number of pellets may be due to the explosion of several shots at a distance. The certainty of the assessments can therefore only result in an explosion of test shots with the suspected weapon (loaded with pellets of adequate size), which will be used for the evaluation, at various distances, of the density of the pellets on the target [15].

- Form of wounds

The round or elliptical shape of the entrance wounds and the disposition of the abraded ring (and/or the secondary phenomena of the shot) provide a first indication of the degree of incidence of the projectile's trajectory; in case of tangential lesions, the examination of its edges may be useful.

- Assessment of intracorporeal lesions

Follow the signs of the advancement of the bullet in the anatomical areas and organs, which can lead to an exit hole or can be interrupted at the site of retention of the bullet, whose position, as well as for skin wounds, will be noted in a system of Cartesian coordinate.

Of course, this reconstruction of the trajectory is only anatomical and doesn't include intra/extra-somatic deviations that may not coincide with the ballistic trajectory of the bullet. Therefore, any judgment on the direction of the shot (be it produced by a single bullet or by several bullets) and expressed based on autopsy data,

will refer only to a standard position of the subject with limbs and torso in anatomical position. However, the possibilities offered by reciprocal variations of different anatomical regions (especially of the head and limbs against the trunk) can be considered [21] [22].

The data obtained from the autopsy will be taken into consideration to evaluate its compatibility with any environmental defect linked to the impact of the bullets. In any case, the reconstruction of the reciprocal position between the victim and shooter must be expressed in terms of compatibility; for example, postural changes in the trunk and head can make a crossing determined by a bullet that has described a horizontal trajectory appear oblique (downwards or upwards) [13].

Therefore, in the absence of elements of evaluation derived from a crime scene, the position of the shooter can only be established generically from what can be inferred from the location of the entry injuries, for example on the front, back, or side of the victim [11].

- Shooting range

It is necessary that surveys of the shooting ranges be made to get an overview of the place where the shooting occurred. In this way, an outline of the locations can be made with placement of all the findings and related legend. This is essential to put forward a correct reconstructive hypothesis.

b) *Single Bullet Injuries* [20]

- Close contact wounds
 - a. On soft tissues
 - b. Possible bruises of the muzzle on the skin; soot and burning at the edges of entrance wounds. Any deposits of soot and cooking residues along with them through and bright red coloration of muscles from carbon monoxide;
 - c. On the scalp above the skull or the skin above the ribs:
 - d. Starry entrance hole, "unglued" edges with deposits of soot and grains of dust in the space between the skin and the bone surface; discontinuous and barely visible excoriated ring due to the presence of lacerations, the red color of the first portion of the loop (carbon monoxide);
- Near-contact shot (distances of up to 5 or 20 cm):
- Dense soot around the inlet hole, sometimes separated by a relatively clean area immediately surrounding the hole; charring and burning at the edges of the hole; bright red color of the first portion of the loop (CO); burning of hair [Intermediate-rangerange shot (20-50 cm) [18]:

Absence of soot, presence or absence of tattoos (about the length of the barrel), and the type of dust. The use of a silencer should always be considered: in some cases, this device can completely abolish the secondary effects of the shot (flame, soot, tattoo) [18].

- Distance shots (over 50 cm)

Absence of any deposits around the entrance hole: it is not possible to further specify the exact distance, if not using other surveys (evaluation of the penetration and comparison with data obtained from experimental test shots) [18].

To determine the firing distance we use the well-known easy-to-field colorimetric method: sodium rhodizonate, in a simple and practical small-size kit, to detect the surrounding skin and clothing.

To ascertain whether the victim had also used firearms the SEM-EDX analysis must always be performed mainly on the hands.

c) *Injuries from Multiple Charges*

- Close

Circular entry hole approximately equal to the diameter of the barrel; regular, blackened margins; possible imprint of the muzzle; significant amounts of soot residues in the passage; red color of fabrics (CO); in areas of the skin in direct contact with the bone surfaces lacerations of the edges of the wound may be found; contact blows of the scalp are always destructive and may require reassembly of the skull fragments in the laboratory to try to identify the entrance lesion;

- Near and intermediate distance

Circular hole with smooth edges; burning of the skin and/or hair; presence in varying amounts of soot and tattoo.

At distances of about 30 cm, the margins begin to have an uneven appearance, the tattoo persists, and hair burns may still be present; the swad penetrates the lesion. The tattoo can sometimes persist for up to 1 meter.

- Long shots

- a. Between 1 and 5 meters → central hole with irregular edges; the presence of "satellite" holes around the edge of the inlet hole. The wad does not penetrate the body at the upper limits of this distance, but it can hit the target causing abrasions and lacerations, reproducing its shape and size.
- b. Over 5 meters → complete diffusion of the pellet with the absence of the central hole. Almost constant presence (usually no more than 8 meters) of wad contusion injuries, often with a figurative appearance.

All the previous data are to be considered approximate especially if it was not possible to carry out the investigation and examination of the garments [23].

A more accurate estimate of the firing distance in cases where firearms have been used (loaded with single bullets, or with pellets) can be achieved with firing tests at various distances using the specific weapon and ammunition [13].

d) *Survival Time*

Evaluate the influence of all the above factors with the different survival hypotheses based on the possibility of sensory integrity and availability of residual resources of the various systems (cardiovascular, respiratory, and musculoskeletal systems) [11].

Any attempt at reconstruction should be based on the preliminary acquisition of the available data, which include the classic biological parameters (type of injury, disposition of this, survival time, etc.), appropriately supplemented by the results of other criminalistic investigations (inspection, examination of ballistic findings, clothing, environmental, circumstantial and testimonial surveys, etc.). Indeed, it will be necessary to consider how long the victim survived the shooting and whether he was able to make subsequent movements. For example, the victim might survive long enough to respond to the shooting or still be able to move away from the scene of the shooting to get to safety.

e) *Other Types of Surveys*

Clothing examination:

The examination of clothing can be of decisive importance, based on the correspondence evaluation of the total number of lesions found on the body; keep in mind the possibility of clothing non-buttoned or raised and fabric folds that can cause numerical inconsistencies.

Virtual autopsy:

Radiological investigations and, above all, a virtual autopsy could provide fundamental help in the search for bullets retained in the body, especially in those cases in which the body is hit by multiple gun bullets, visualizing the bullets and the effects thanks to radiological investigations can help in reconstructing the event.

Vehicle Examination:

- The presence of completely shattered crystals which may not be an expression of the action of a bullet, or may mask the passage of several bullets;
- Check all the trajectories reconstructed on the vehicle;
- Search the cockpit for firearm residues;
- Evaluate firing distance and report the characteristics of the materials involved progressively by each bullet along trajectories for experimental laboratory tests;
- Reconstruct the direction of the shots and demonstrate it with appropriate graphic methods, expressing the appropriate reservation in the case of completely shattered glass;
- To determine if the vehicle was in motion at the time it was hit, the evaluation of all acquired data can allow one to express an opinion on the sequence of shots;
- Answer if it is possible only after the laboratory tests on how many weapons they have fired. Therefore, it

may be necessary to repeat the examination of the car as the laboratory data is provided;

- In addition to the surveys of the trajectories of the bullets through the car's structure, the analysis of the biological traces possibly found in the car is of fundamental importance. Possibly useful use of luminol or alternative light sources.

f) *Proof and Illustration of Conjectures*

The final phase of any criminalistics investigation is the reconstruction of the event, that is the interpretation and recomposition of the various elements of evidence and the overall evaluation of the same to the legal characterization of the event; In other words, the effort to determine or hypothesize how much more reliably and chronologically correct the various phases of a criminal episode are.

In Forensic Ballistics, perhaps even more than in other disciplines, graphic visualizations will facilitate the understanding of the various hypotheses.

The most important methodologies, more or less widespread, sometimes not updated, but cheap and easy, are:

- Freehand or computer graphics design: the more traditional one, not without major application problems.

Advantages: low cost, ease, and speed of use.

Disadvantages: two-dimensionality and risk of excessive approximation.

- Use of rigid rods and photographs: widely used in the United States by the police.

Benefits: low cost, three-dimensional, good level of approximation. *Disadvantages:* highlights short trajectories.

- The use of flexible highlighters (threads) and photographs allows the highlighting of longer trajectories.

Benefits: low cost, three-dimensional, good level of approximation. *Disadvantages:* relative difficulty of the method.

- Use of three-dimensional human models, real or simulated: allows a good visual rendering.

Advantages: low cost, three-dimensionality. *Disadvantages:* risk of excessive approximation [24] [25].

- Three-dimensional reconstruction in the scale of closed or open spaces allows the reconstruction of even very long trajectories.

Advantages: Accuracy. *Disadvantages:* complexity and trajectory documentation problems.

Advantages: the three-dimensional, ability to break down the action into detailed sequences, acceleration, and deceleration of execution times, and the possibility of real-time illustration of the possible variants.

Disadvantages: very high cost and complexity of implementation; too suggestive compared to other possibilities of reconstruction [21] [22].

- Laser pointers and telemetry: highlights very long trajectories.

Advantages: Accuracy.

Disadvantages: Complexity and trajectory documentation problems.

- Vector CAD and computer-animated simulation: Widespread in the USA in all areas of forensic reconstructions.

Advantages: three-dimensionality, ability to break down the action into detailed sequences, acceleration, and deceleration of execution times, and the possibility of real-time illustration of possible variants. *Disadvantages:* very high cost and complexity of implementation; too suggestive compared to the other possibilities of reconstruction [26].

V. CONCLUSIONS

With this manuscript, the Authors want to provide useful elements so that the medical examiner can integrate his knowledge and provide valid answers to the questions posed by the judge [27].

What emerges from what has been analyzed indicates that to face an autopsy in which firearms were used, it is necessary to integrate the main notions of Forensic Traumatology with those of Ballistics.

REFERENCES RÉFÉRENCES REFERENCIAS

1. Shrestha R, Kanchan T, Krishan K. Gunshot Wounds Forensic Pathology. 2020 Apr 15. In: StatPearls. Treasure Island (FL): StatPearls Publishing; 2020 Jan-. PMID: 32310579. PMID: 32310579; Bookshelf ID: NBK556119.
2. Pafko P, Mach J. Lege artis [Lege artis]. *RozhlChir*. 2013 Aug; 92(8):467-9. Czech. PMID: 24274350.
3. Cave R, DiMaio VJ, Molina DK. Homicide or suicide? Gunshot wound interpretation: a Bayesian approach. *Am J Forensic Med Pathol*. 2014 Jun;35(2):118-23. DOI: 10.1097/PAF.000000000000085. PMID: 24781397.
4. Eckert WG, Bell JS, Stein RJ, Tabakman MB, Taff ML, Tedeschi LG. Clinical forensic medicine. *Am J Forensic Med Pathol*. 1986 Sep; 7(3):182-5. doi: 10.1097/00000433-198607030-00002. PMID: 3788904.
5. Fackler ML. Gunshot wound review. *Ann Emerg Med*. 1996 Aug; 28(2):194-203. DOI: 10.1016/s0196-0644(96)70062-8. PMID: 8759585.
6. Breeze J. et al. Ballistic trauma. A Practical Guide. 4th Edition. Springer.
7. Molina DK, DiMaio V, Cave R. Gunshot wounds: a review of firearm type, range, and location as about manner of death. *Am J Forensic Med Pathol*. 2013 Dec;34(4):366-71. DOI: 10.1097/PAF.00000000000000065. PMID: 24196728.
8. Nikolić S, Zivković V, Babić D, Juković F. Suicidal single gunshot injury to the head: differences in site of entrance wound and direction of the bullet path between right- and left-handed--an autopsy study. *Am J Forensic Med Pathol*. 2012 Mar; 33(1):43-6. DOI: 10.1097/PAF.0b013e31823a8a32. PMID: 22083074.
9. Randall T. Clinicians' forensic interpretations of fatal gunshot wounds often miss the mark. *JAMA*. 1993 Apr 28; 269(16): 2058, 2061. DOI: 10.1001/jama.269.16.2058. PMID: 8468745.
10. Lorin de la Grandmaison G. Blessures par projectile d'arme à feu: aspects anatomopathologiques [Gunshot wounds: forensic pathology]. *Ann Pathol*. 2012 Feb; 32(1):33-9. French. doi: 10.1016/j.annpat.2011.10.005. Epub 2012 Jan 17. PMID: 22325312.
11. Yaremchuk VO. The use of medical knowledge in the crime investigation. *Wiad Lek*. 2019; 72(1):103-106. PMID: 30796872.
12. Handlos P, Joukal M, Dokoupil M, Uvíra M, Marecová K. Necessary Defense or Homicide?: The Importance of Crime Scene Reconstruction in Crossbow Injuries. *Am J Forensic Med Pathol*. 2019 Sep; 40(3):293-297. DOI: 10.1097/PAF.0000000000000493. PMID: 31205059.
13. Padosch SA, Schmidt PH, Schyma C, Hirsch RD, Kröner LU, Dettmeyer RB, Madea B. Rechtsmedizinische Aspekte des Suizides durch Kopfschussverletzungen. Teil II: Rechtsmedizinische Befunde und Schusshanduntersuchung [Medicolegal aspects of witnessed suicide due to a gunshot to the head. II. Legal medicine aspects and examination of the firing hand]. *Arch Kriminol*. 2004 Nov-Dec; 214(5-6):149-62. German. PMID: 15666971.
14. Biver A. Cas particulier des traumatismes vasculaires par projectiles de guerre [Special cases of vascular injuries by war projectiles]. *Acta Chir Belg*. 1982 Sep-Oct;82(5):457-61. French. PMID: 7148288.
15. Stevenson T, Carr DJ, Harrison K, Critchley R, Gibb IE, Stapley SA. Ballistic research techniques: visualizing gunshot wounding patterns. *Int J Legal Med*. 2020 May; 134(3):1103-1114. doi: 10.1007/s00414-020-02265-5. Epub 2020 Feb 14. PMID: 32060625; PMCID: PMC7181419
16. Mahoney P, Carr D, Harrison K, McGuire R, Hepper A, Flynn D, Delaney RJ, Gibb I. Forensic reconstruction of two military combat related shooting incidents using an anatomically correct synthetic skull with a surrogate skin/soft tissue layer. *Int J Legal Med*. 2019 Jan; 133(1):151-162. doi: 10.1007/s00414-018-1802-z. Epub 2018 Mar 7. PMID: 29516250; PMCID: PMC6342880.
17. Jacob B, Barz J, Haarhoff K, Sprick C, Wörz D, Bonte W. Multiple suicidal gunshots to the head. *Am J Forensic Med Pathol*. 1989 Dec; 10(4):289-94. DOI:

- 10.1097/00000433-198912000-00003. PMID: 2589288.
18. Price TG, O'Neill RM. EMS Crime Scene Responsibility. 2020 Oct 28. In: StatPearls [Internet]. Treasure Island (FL): StatPearls Publishing; 2020 Jan-. PMID: 29763175.
 19. Kabaliuk N, Jermy MC, Williams E, Laber TL, Taylor MC. Experimental validation of a numerical model for predicting the trajectory of blood drops in typical crime scene conditions, including droplet deformation and breakup, with a study of the effect of indoor air currents and wind on typical spatter drop trajectories. *Forensic Sci Int.* 2014 Dec; 245:107-20. DOI: 10.1016/j.forsciint.2014.10.020. Epub 2014 Oct 18. PMID: 25447183.
 20. Martrille L, Symes SA. Interpretation of long bones ballistic trauma. *Forensic Sci Int.* 2019 Sep; 302:109890. DOI: 10.1016/j.forsciint.2019.109890. Epub 2019 Jul 30. PMID: 31421439.
 21. Stevenson T, Carr DJ, Penn-Barwell JG, Ringrose TJ, Stapley SA. The burden of gunshot wounding of UK military personnel in Iraq and Afghanistan from 2003-14. *Injury.* 2018 Jun; 49(6):1064-1069. doi: 10.1016/j.injury.2018.03.028. Epub 2018 Mar 27. PMID: 29609973
 22. Mahoney P, Carr D, Arm R, Gibb I, Hunt N, Delaney RJ. Ballistic impacts on an anatomically correct synthetic skull with a surrogate skin/soft tissue layer. *Int J Legal Med.* 2018 Mar; 132(2):519-530. doi: 10.1007/s00414-017-1737-9. Epub 2017 Nov 28. PMID: 29185026; PMCID: PMC5807523
 23. Beat P. Kneubuehl *Editor.* Wound Ballistics. Basics and Applications. 2nd Ed
 24. Bell S, Feeney W. Single shot, single sample, single instrument detection of IGSR and OGSR using LC/MS/MS. *Forensic Sci Int.* 2019 Jun;299:215-222. DOI: 10.1016/j.forsciint.2019.04.002. Epub 2019 Apr 13. PMID: 31051336.
 25. Tuchman L, Gorincour G, Kolopp M, Mariani P, Léonetti G, Piercecchi-Marti MD, Bartoli C. Combined use of postmortem 3D computed tomography reconstructions and 3D-design software for post-mortem ballistic analysis. *DiagnInterv Imaging.* 2017 Nov;98(11):809-812. DOI: 10.1016/j.diii.2017.06.016. Epub 2017 Jul 21. PMID: 28739434.
 26. Wang J, Li Z, Hu W, Shao Y, Wang L, Wu R, Ma K, Zou D, Chen Y. Virtual reality and integrated crime scene scanning for immersive and heterogeneous crime scene reconstruction. *Forensic Sci Int.* 2019 Oct; 303:109943. DOI: 10.1016/j.forsciint.2019.109943. Epub 2019 Sep 13. PMID: 31546165.
 27. Vinci F., Stellacci A., Perrone C. *Medicina legale e balistica forense. La ricostruzione scientifica di reati consumati con armi da fuoco.* Aracne Ed, 2020.



This page is intentionally left blank



GLOBAL JOURNAL OF MEDICAL RESEARCH: I
SURGERIES AND CARDIOVASCULAR SYSTEM
Volume 24 Issue 1 Version 1.0 Year 2024
Type: Double Blind Peer Reviewed International Research Journal
Publisher: Global Journals
Online ISSN: 2249-4618 & Print ISSN: 0975-5888

Technologies that will Transform Healthcare

By J Tasič, R. Komadina & I. Škrjanc

Abstract- With the emergence of the latest sensor technologies, fast computer systems, useful artificial intelligence in healthcare, the processes of rapidly changing methods of healthcare for individuals and healthcare services began to be implemented. With increasing environmental pressure to use the latest advances in sensors and smart data mining, algorithms and processes are emerging that enable improved care and patient satisfaction while reducing costs, thereby enabling hospitals to become increasingly better in the areas of diagnosis, treatment, as well as prevention. All this increases their performance and competitiveness.

With the exponential growth of computing power and artificial intelligence algorithms, a noticeable leap is seen in many areas of healthcare. Thus, we observe that artificial intelligence is increasingly becoming the main component of successful clinical practice. The purpose of the present review is to provide a general introduction and overview of AI in medicine with a special focus on future perspectives in surgery.

Therefore, it is important that medical workers, especially emergency physicians and surgeons, which is the focus of this lecture, gain insight into artificial intelligence methods by understanding the operation of new technologies in healthcare.

Keywords: *technologies in healthcare, sensor technologies, healthcare, robotic surgery, artificial intelligence, databases.*

GJMR-I Classification: *NLMC Code: WO 500 NLMC*



Strictly as per the compliance and regulations of:



Technologies that will Transform Healthcare

J Tasič ^α, R. Komadina ^σ & I. Škrjanc ^ρ

Abstract- With the emergence of the latest sensor technologies, fast computer systems, useful artificial intelligence in healthcare, the processes of rapidly changing methods of healthcare for individuals and healthcare services began to be implemented. With increasing environmental pressure to use the latest advances in sensors and smart data mining, algorithms and processes are emerging that enable improved care and patient satisfaction while reducing costs, thereby enabling hospitals to become increasingly better in the areas of diagnosis, treatment, as well as prevention. All this increases their performance and competitiveness.

With the exponential growth of computing power and artificial intelligence algorithms, a noticeable leap is seen in many areas of healthcare. Thus, we observe that artificial intelligence is increasingly becoming the main component of successful clinical practice. The purpose of the present review is to provide a general introduction and overview of AI in medicine with a special focus on future perspectives in surgery.

Therefore, it is important that medical workers, especially emergency physicians and surgeons, which is the focus of this lecture, gain insight into artificial intelligence methods by understanding the operation of new technologies in healthcare.

Keywords: technologies in healthcare, sensor technologies, healthcare, robotic surgery, artificial intelligence, databases.

I. INTRODUCTION

Technologies that have already and will continue to have a strong impact on the transformation of healthcare are closely related to capture, data exchange, artificial intelligence, smart control, visualization with simulation, 3D printing and robotics, which are made possible by technologies in the field of automatic data processing and broadband communication technologies. All of the above, including the Internet, ambient devices and intelligent computer systems, are causing an increasing use of these technologies in medical practice. Thus, technologies from the field of Automation and ICT technology, through the increasingly widespread use of supported health services, also affect social relations.

In addition to ICT technologies, which already have and may have had a great impact on the transformation of healthcare, technologies such as: remote monitoring of vital parameters (Telehealth), artificial intelligence, 3D printing technologies (organs, parts of the skeleton), augmented and virtual reality, wearable non-invasive sensors, digitization, robotic

surgical systems and the development of bioinformatics smart structures.

We predict that the increasing aging of the population, the rise of chronic diseases, natural and other disasters, and the increased demand for real-time monitoring and patient care systems will accelerate the use of artificial intelligence in almost all areas of healthcare. In order to achieve the mentioned goals, it is necessary to increase the knowledge of the medical staff in the areas of application of the mentioned technologies. In addition to these, it will be necessary to look for support in making quality diagnoses, support in image analysis, 3D printing, simulation of surgical interventions, design of custom devices and tools, improvement of the accuracy of medication action, augmented and virtual reality, simulation of treatment procedures, augmented and virtual reality, wearable body sensors, improved patient participation, as well as the next generations of technology-supported healthcare.

II. IMPORTANT KNOWLEDGE OF MEDICAL STAFF

If we want to develop superior health care and expand it into widespread use in all branches of medicine, we must also properly educate doctors and support staff so that they can successfully use all the latest achievements in the treatment and rescue of patients. Since these skills are complex, and since the methods that support the aforementioned procedures are based on real data, it is important that only these are systematically managed throughout the healthcare system, while at the same time they are accessible to artificial intelligence methods, which increasingly support too many areas of healthcare. As the doctor becomes burdened with new challenges, let's give just a few basic technological areas important for successful treatment.

a) *Unified Database*

One of the biggest challenges in healthcare today is the lack of data sharing between healthcare providers. Almost no patient information is shared between providers, causing delays and potentially harmful patient treatment that could be avoided by implementing a single shared database. The secure exchange of patient data and information between healthcare providers is one of the most important advances of our time. Withholding patient data and information leads to unnecessary healthcare costs. This

Author α: e-mail: radko.komadina@gmail.com

greatly affects the duplication and thus the redundant bio-medical analyzes and examinations that are carried out. Such closing of patient data and information can also lead to inadequate treatment, which can also be dangerous. Shared databases can help bridge the gap by giving healthcare professionals direct and easy access to critical patient data and information. Thus, the safe exchange of data and information about patients between health service providers and the support of the analysis of this data using artificial intelligence will represent one of the most important advances in medicine in the coming decade.

b) *Artificial Intelligence*

Artificial intelligence (AI) is one of the most powerful tools in today's modern knowledge-based medicine systems. The power of artificial intelligence lies in its fast and detailed analysis of large amounts of data. Artificial intelligence enables real-time monitoring of all vital functions and thus high-quality, professional and affordable health care. By analyzing the data, it also helps healthcare workers to diagnose disease states, as well as to make the best decisions in the treatment of patients. Artificial intelligence is also helpful in managing and performing tedious and time-consuming administrative tasks. Using learning methods, we can develop models from known data that help predict the outcome of a certain patient treatment procedure. These are supervised learning methods, while unsupervised learning methods mainly look for patterns or similarities between data.

c) *Predictive Data Analysis*

Artificial intelligence (AI) and machine learning (ML) are already being used for predictive analytics in healthcare. AI and ML can help predict possible patient conditions by analyzing patient data on the fly, on the basis of which we can save their lives. By analyzing vital data, the system can monitor the patient's response to certain drugs or treatment protocols. Based on the remote monitoring of this data, the system will analyze which patients are likely to be readmitted to the hospital and for which reasons.

Real-time predictive analytics of patient and family data also enables preventive treatment of patients, because a timely medical history can mean how to avoid a patient's admission to the hospital.

d) *AI Assistance in Medical Image Analysis*

Artificial intelligence already has a strong influence on the transformation of healthcare. We can ask ourselves, how do doctors understand what is practically happening in the dynamic space of artificial intelligence? Pattern recognition algorithms supported by artificial intelligence transform a winter landscape image into a spring blooming scene.

Today, we've reached a point where pattern recognition algorithms and artificial intelligence (AI) are

more accurate than radiologists at spotting breast cancer images and other medical features that involve correlations between normal and abnormal patterns.

Artificial intelligence can therefore identify changes in imaging patterns faster than a top radiologist, which can help diagnose, track, progress and respond to disease treatment. The approach to the analysis of patients' imaging material using artificial intelligence represents a great support and potential for clinical decisions in time-critical situations or when there is a lack of available expertise. This aid represents an important support for medical staff in cases of remote or poorly funded medical institutions. AI is not only used in the evaluation of conventional radiological examinations, but also in cases of computed tomography (CT) and magnetic resonance imaging (MRI).

We use artificial intelligence where it enables better and more successful treatment, thereby increasing the quality of treatment and thus the credibility of the hospital.

Artificial intelligence is generally divided into 10 functional areas [19]:

1. Deduction, reasoning and problem solving.
2. Knowledge representation: useful information about the real-world objects of the problem.
3. Machine learning.
4. Robotics, which means movement and manipulation and the recognition of efficient paths.
5. Planning: the system's ability to set goals and achieve them.
6. The process of communication in natural language.
7. Perception and computer vision.
8. Social intelligence for recognition, interpretation and simulation of human movements.
9. Creativity, which means a combination of theoretical and practical solution design.
10. General intelligence, which means autonomous thinking, and machine learning intelligence.

e) *AI and Diagnosis*

Reading and real-time analysis of a huge amount of data is a big problem for doctors, as the results of data analysis are important for making a diagnosis. Artificial intelligence, like a top specialist, "examines" the patient's electronic medical record together with all imaging elements, captured vital parameters and laboratory results faster and more efficiently by connecting all this data to the existing database, and compares it with examples of patients from around the world. Based on feature analysis and comparison, the AI algorithm makes a diagnosis proposal. The system supported by AI methods only helps the doctor in making a diagnosis, the final decision is always in the domain of the diagnostician.

In the field of AI in medicine, there are a number of interesting companies that are already and are ready

to participate in the development of models that promote quality and two levels of treatment. These are:

Imagia: artificial clinical intelligence for early detection of cancerous changes.

Butterfly: for successful medical imaging accessible to everyone in the world.

Mindshare: medicine with image-driven intelligence.

Bay Labs: deep learning on critical unsolved problems in healthcare.

Zebra: Algorithms help radiologists discover often-overlooked indications.

Behold.Ai: an artificially intelligent medical imaging platform.

A Tomwise: Developer of AtomNet's deep learning technology for small molecule detection.

Pathway Genomics: combining artificial intelligence and deep learning in precision medicine.

Advenio: Provides machine learning-based artificial intelligence, deep learning, and computer aided discovery (CADx) for diagnostic clinical imaging.

Enlitic: Uses deep learning to extract actionable insights from a multitude of clinical cases.

Lunit: development of advanced software for analysis and interpretation of medical data.

Sig Tuple: building intelligent screening solutions to aid diagnosis.

Insilico Medicine: Artificial Intelligence for Drug Discovery, Biomarker Development.

Medymatch: a method to prevent chronic diseases and improve patient treatment.

Intuitive: Da Vinci robotic systems for surgical care.

The assessment of the potential of artificial intelligence in medicine begins with understanding the framework of the operation of AI using the solutions offered by the mentioned foreign as well as domestic research and development-oriented companies /20/.

f) 3D Scanning in the Medical Field

When capturing information about internal organs, we see the use of a set of different scanning methods such as X-rays, CT, MRI and ultrasound. Unfortunately, there is a methodological gap in obtaining data on external body parts. With the advent of 3D scanners that allow accurate measurement of the size, shape, texture, color and surface of human skin, a new area of clinical application is emerging, ie high-resolution 3D scanning. It is useful to support these methods with the results of X-ray measurements, computed tomography, magnetic resonance and ultrasound.

Today, 3D scanning tools have already been developed for commercial medical applications, where

together with analysis data, simulations and the final model, we arrive at the rapid production of effective customized medical implants. With a 3D scanner, a set of captured images is combined into a virtual 3D model, where we also use the technologies of stereo vision, photogrammetry and peripheral projections.

3D objects can be easily produced with a printer that follows the data from a 3D scanner. 3D scanning service as well as 3D printing are crucial for many fields of medicine. The emphasis in the development of the model is on the time, accuracy of the implant reconstruction, as well as its improvement.

g) 3D Printing

Creating anatomical models using 3D printing enables the creation of physical models of anatomically accurate patient structures that can be used for surgical planning and education for both patients and trainees. This is extremely beneficial for complex surgical procedures where any error could be harmful, as can be the case in neurosurgery. This revolutionary technology will improve patient care by better training medical staff and increasing the effects of personalized health solutions. To generate an appropriate medical image model, appropriate supporting software such as 3D Slicer 3DIM Viewer is required. The information generated by the 3D scanner helps surgeons and radiologists to control and select the correct MRI or CT segmentation. Segmentation and visualization data are converted into a uniform STL format that can be used in other applications.

By 2025, 3D printing in the medical field is expected to be worth around 3.2 billion euros with an expected annual growth rate of 17.7%.

h) Custom Design of Devices and Tools

Medical devices, prosthetics, dental implants and even surgical tools can now be customized to the patient or user. Sterile surgical instruments such as forceps or scalpel handles can be manufactured at significantly lower costs. 3D printed prosthetic limbs or implants that are specially adapted to the user have the same functionality as traditionally made prosthetic elements, but they can be made faster and cheaper.

i) Augmented and Virtual Reality

Augmented and virtual reality (AR and VR) caused first a real confusion, and then a real revolution in medicine. The first VR applications started in the early 1990s due to the need of medical personnel to visualize complex medical data, especially during surgery or for surgery planning. VR can also be described in terms of human experience as "a real or simulated environment in which the observer experiences telepresence", where telepresence can be described as a sense of presence (Riva, 2003) in the environment through communications." Augmented reality is popular in various fields. medicine. Its use in medicine is a more

and more promising technique for operations that require great precision. The use of augmented and virtual reality in the medical field shows promising results. With the help of augmented and virtual reality, doctors will be trained, and at the same time, these technologies can represent a therapeutic tool for treating patients.

j) *Simulation of Medical Procedures*

Augmented and virtual reality (AR and VR) allow the realization of detailed simulations of medical procedures, allowing doctors to walk through one, two or a hundred procedures before starting to work directly with a patient. Simulation technology has become so good that doctors and medical students can practice with superior accuracy on the problem itself, while experiencing simulations and procedures with near-total immersion in the problem. This gives the ability to make decisions and review results without putting the patient at risk while experimenting and learning.

k) *Wearable Body Sensors*

As the diversity of wearable technology systems and applications increases, they are expected to become an indispensable part of our lives, much like smartphones were in the past. With today's long-lasting small batteries, with data exchange via a WiFi communication channel and with the support of real-time data acquisition of vital functions, wearable non-invasive sensors will quickly become an integral part of monitoring and caring for the user's health.

l) *Timely Diagnosis and Clinical Support*

Wearable body smart vital signs sensors have rapidly expanded to allow real-time collection of clinically relevant medical data. Combined with well-designed mobile apps, users can view the analysis of their collected data and also share it with their healthcare professionals. Users can also receive alerts in case of detected irregular courses of vital parameters such as heart rate, breathing rate, etc., which may indicate a serious patient condition. The mentioned technology of real-time capture of vital parameters can, by using other patient data and AI methods, enable the timely diagnosis of a dangerous health condition of patients, even before it worsens and/or becomes life-threatening.

m) *The Next Generation of Technologically Supported Healthcare System*

The next technology-supported generations of the healthcare system (NGS) will have a strong impact on changes in healthcare. The next generations are expected to play a central role in the development of personalized medicine, to enable, with their potential, great added value in clinical and research projects, both at the level of the individual and the nation. The main advantages of new technologies are the enormous increase in the quality of diagnosis, the reduction of

healthcare costs, the improvement of the quality of life of patients and the advancement of medical science and innovation.

n) *Smart Healthcare Communication Networks in the Hospital of the Future and Data Structures*

The concept of the Hospital of the Future (HoF) will mainly enable the wireless connection of patients, healthcare workers, sensors, computers and medical devices.

To meet the stringent requirements of future healthcare scenarios, such as improved performance, security, privacy and spectrum utilization, we propose a flexible hybrid optical-radio wireless network that provides efficient, high-performance wireless connectivity for the hospital of the future. The concept of the connected hospital of the future takes advantage of flexible hybrid optical-radio networks. Such networks can be dynamically reconfigured to meet the needs of communication over optical or radio communication channels, depending on the requirements of the current service. We envisage that the communication network of the hospital of the future will consist of many communication devices and hybrid optical-radio access points for data transmission. Communication systems based on the use of visible light exploit the idea of visible light communication (VLC), where white light-emitting diodes (LEDs) provide both room illumination and optical wireless communications (OWC). A hybrid radio-optical communication system can in principle be used in any future hospital scenario.

In addition to hybrid access, we also envisage the use of a reconfigurable optical - radio communication wireless network (WBAN), which enables the expansion of a conventional WBAN network to a more general, application-adaptive network. As the radio spectrum becomes more and more congested, the hybrid wireless network approach is an attractive solution for more efficient use of the spectrum. The HoF concept aims to improve healthcare while using hospital resources efficiently.

This type of solution, which combines optical and radio transmission networks, would increase spectral efficiency, privacy and at the same time reduce the exposure of patients to radio signals (RF).

The huge increase in new communication technologies such as 4G and 5G, the increase in the use of wearable Internet of Things (IoT) sensors and the increase in wireless medical communication devices could lead to spectrum congestion, security and privacy issues for users of radio networks.

Therefore, in the case of smart hospitals and smart healthcare, we need to use the aforementioned technologies in transforming conventional care into patient-centered care. The aforementioned adaptive networks, together with the 5G and 6G technologies announced today, represent an impetus for a rapid

revolution in the healthcare vertical. Currently, 4G and other communication standards are used in healthcare for smart health services and applications. The aforementioned technologies are crucial for the development of future smart healthcare services.

With the growth of the healthcare industry, more and more applications are expected to generate huge amounts of data in various shapes and sizes. Such large and diverse data require special consideration in terms of time-consuming point-to-point connections, bandwidth, time-consuming processing, etc. Current communication technologies have a hard time meeting the demands of the highly dynamic and time-sensitive healthcare applications of the future.

Therefore, today's 5G networks are being developed to address the diverse communication needs of Internet of Things (IoT) healthcare services. Today's smart healthcare networks, with the help of the 5G standard, represent the convergence of IoT devices that require improved network performance and cellular coverage. Current IoT connectivity solutions face challenges such as supporting a huge number of devices, standardization, energy efficiency, device density and security.

6G. This next generation of wireless technology is expected to deliver even higher speeds, lower latency and higher bandwidth for the instantaneous delivery of massive amounts of data in decentralized, intelligent networks.

6G is now in the research phase and while it is still a little early to name the killer applications, some predict that it will become an integral part of our society. One focus for 6G is a further step towards "always-on" and "lag-free" communications, including very high data rates. This will significantly increase productivity and drive new opportunities in automation, artificial intelligence (AI) and the Internet of Things (IoT).

ICT technologies have changed the way medicine is practiced and taught. Therefore, we must also delve deeper into the study of the challenges facing medical education in the age of ICT. They are:

- Preparing for the changing behavior of Internet-savvy patients.
- Raising awareness of the benefits of using ICT
- Motivating medical students and doctors to use ICT for information seeking, learning and development

III. ARTIFICIAL INTELLIGENCE AND ROBOTICS IN SURGERY

a) *Surgery and Robotics*

Artificial intelligence is now seen as an aid to surgery rather than a replacement for an actual surgeon. The use of artificial intelligence in surgery, together with surgical robotics, patient scanning and 3D visualizations, is already causing significant changes in

surgical procedures on both sides, both the surgeon and the patient.

The use of artificial intelligence in the learning and training of surgeons is very important. This training is undergoing significant changes, as simulation methods with the support of artificial intelligence create the possibility of learning from virtual surgical procedures. Both surgeons and trainees can practice skills in a controlled environment, developing new surgical methods and increasing their understanding of more complex procedures. The use of artificial intelligence and simulation processes in the training of surgeons improves the quality and efficiency of work. With this approach, young specialists in the field of surgery can increase the quality of their knowledge, as they acquire a certain level of competence for further work.

Robot-assisted surgery is one of the most important technological achievements in the field of surgery in the last two decades [1]. With the introduction of laparoscopic - minimally invasive surgery (MIK), this procedure allows surgeons direct access to internal organs, which creates the need to improve ergonomics and creates the need for intelligent support of the robotic manipulator. MIK is accessed through small openings, using specialized instruments and cameras (laparoscope) to observe the operation site. Robotic-assisted MIS (RMIS) uses the same principles, where the instruments are the same, except that they are driven by motors and control systems that provide greater instrument dexterity and precision, as well as effective visualization at the surgical terminal. Such a surgical system is da Vinci (Intuitive Surgical Inc., USA), which is widespread throughout the world and also here in Slovenia.

The development of management methods and artificial intelligence methods have greatly influenced the efficiency of robot-assisted surgery. In this, artificial intelligence methods have proven to be widely applicable, such as in the training of surgeons, in the simulation of surgical interventions, in intraoperative decision-making, in predicting events, as in preoperative planning of major operations, management of complications and re-certification of surgeons [2/].

A surgical robot is therefore an autonomous, computer-controlled device that can be programmed in such a way as to represent an important aid to the surgeon in positioning and working with instruments, as well as in solving increasingly complex problems. [1] The systems currently in use are not intended to operate independently of the surgeon. These systems act as extensions of the arms, fully controlled by the surgeon, and are best described as manipulators. The surgeon's main console represents the user interface of the robot, which provides the surgeon with functions such as a three-dimensional view with the help of an endoscopic camera, control of the manipulators used by the

surgeon during the surgical procedure, as well as scaling, which means converting the surgeon's natural movements into filtered micro-movements, which increases the accuracy of the manipulator's hand movements.

Development and research in the field of surgical robots require intensive cooperation of several research areas. The structuring of these research efforts was published in the article/ *Autonomy+in+Surgical+Robotics/* from 2017. Autonomy of surgical robots is defined by the International Organization for Standardization (ISO 8373:2012) as "the ability to perform a planned task based on current state and perception without human intervention." However, "autonomy" is not a single state, but a set in which the degree of human intervention is inversely dependent on the degree of robotic autonomy - independence. Examples of robotic surgical devices with variable autonomy are robots from Intuitive Surgical, Sunnyvale, CA, USA.

The degree of autonomy of surgical robots is divided into six levels in the mentioned article, namely:

- Without autonomy,
- Help the robot
- Task autonomy,
- Conditional autonomy,
- High autonomy and
- Complete autonomy.

This classification is inspired by the definition of the level of "automated driving" in the automotive field. Incorporating autonomy into the work of a surgical robot raises many questions regarding the ethical, medical, legal and social aspects of autonomy. These problems are being discussed around the world, especially from the point of view of ethics and safety, as we can expect that researchers will offer solutions that will allow autonomous robots to offer greater patient safety, higher quality of treatment and at the same time reduce the burden on medical staff. Here, a positive social perception of surgical robots is important from the point of view that hospitals do not become factories and patients become facilities on a conveyor belt.

It is also important to distinguish between automatic and autonomous operation /*Autonomy and Surgical Robotic/*. Automatic operation is completely predictable, following either deterministic or probabilistic processes. At a basic level, the robot actually performs movements on the patient's side, which are controlled by the surgeon via a control interface. Here we do not encounter machine decision-making, but all decision-making is left to the surgeon. If the variations of the external parameters are too large, the system may also fail in such a case. In such a case, the autonomous system is able to adapt to changed external conditions, since its adaptation requires deep knowledge and the

use of cognitive tools, which do not exist in the classic automatic control of a robot system.

b) *Adaptive Control of Robots*

Robot control is the process by which we influence the behavior of a robot system in order to achieve the desired performance. We therefore need a control system because the real operation of the robot system can deviate from the desired operation. The robotic system is always located in an environment that also determines the robot's operating space. When controlling a system, ie a robot, we are talking about input and output parameters, and the control system itself acquires information about the system and the environment via sensors, and on the basis of these parameters and algorithms, determines the control signals used to control the robot. Here we are talking about influencing or input parameters and output parameters. An essential part of control, or process management or robot management, is therefore the real-time acquisition of various information such as coNo

- Information about the desired
- Information about the criterion that defines the modes of operation,
- Information about the management system,
- Information about nodding signals,
- Information about restrictions.

By observing the activity, we create an appropriate knowledge base that enables the robot to be guided to the desired goal. This is how we get to the step when the system thinks and decides. Here, the quality of management depends on the management method and the timeliness of the robot system's response. In order for the response to be adequate, the robotic system must act in such a way that it takes into account all the limitations of time, space and process parameters.

Thus, when controlling a robot, we are dealing with the environment, with goals, with criteria, with limitations, such as with observation, reasoning or learning, and with action. All these activities are carried out by the process computer in real-time, according to the appropriate steps, which is why we are talking about real-time closed-loop computer control of the robot. (Figure 1).

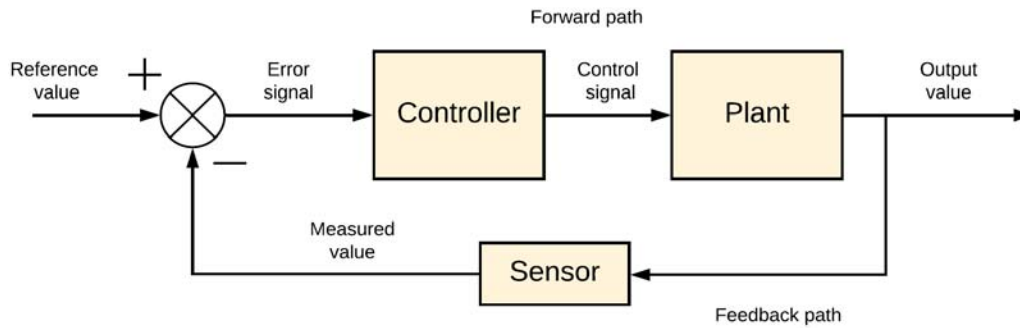

Figure 1: The basic principle of controlling the robot system

In this closed-loop control system, which is the basis for controlling individual robot assemblies, the error signal is the input to the control unit. The error signal is the calculated difference between the input desired signal and the feedback measured signal. By reducing the error, we stabilize the system output so that the desired value is reached at the system output. By using closed-loop control, the system minimizes system error. A block diagram from figure 1 representing a closed loop system and explaining the use of at least one sensor and controller e.g. robotic units. Output signal e.g. of the robot arm (of the system), is compared with the desired value in the summing unit. The difference between the two values, which represents an error, is transferred to the control unit, which, based on the built-in algorithm, manages the output control signal, e.g. robotic arm until the desired and output values are equal.

An important step in robot control is the development of a dynamic model of the robot and the working environment. Usually, in the modeling phase, we develop a non-linear mathematical model, which we transfer into the appropriate computer language. After the analysis and validation of the model, we move on to the synthesis phase of the robot control, the goal of which is the desired speed and accuracy of reaction when the desired values are changed. After planning the guidance, we move to the phase of evaluating the operation of the robotic system in a real environment, where we must take into account all the requirements that we determined at the beginning of planning the development of the process of guiding the surgical robot. During the entire planning, we must also take into account the dynamics of the robot and the flexibility of the joints of the robot manipulators. The dynamics of the robot is very non-linear, which is why even classical planning is difficult. Based on the variation of the limits, the control parameters are determined, with which we achieve the stability of the closed-loop system from Figure 1. The flexibility of the joints is an important component of the robot dynamics, but due to this flexibility, the control efficiency is very complex, if it is compared to the control of rigid robots.

For the sake of the complexity and flexibility of the robot joints, we start adaptive techniques, when the response of the robot system's environment is also time-varying, it is impractical to change the parameters for every change in the environment, which requires the use of an adaptive type of control model. The basic solution lies in the use of an adaptive robot control procedure. . control. Therefore, in doing so, we typically use two adaptation algorithms and they are:

- Least-Mean-Square LMS and
- Recursive-Least-Squares RLS,

Where the basic process of adjusting model weights is represented by the equation:

$$w(k+1) = w(k) + e(k) f\{d(k), x(k)\}$$

Changes according to the Least-Mean-Square LMS algorithm are defined by the expression:

$$w(k+1) = w(k) + 2\mu \cdot x(k)e(k),$$

where μ means expression

$$0 < \mu < \frac{1}{\lambda_{max}}$$

learning speed.

With the Recursive-Least-Squares RLS algorithm, with the expression:

$$w(k+1) = w(k) + R^{-1}(k)x(k)e(k)$$

And expression

$$R^{-1}(k) = R^{-1}(k-1) - \frac{R^{-1}(k-1)x(k)x(k)^T R^{-1}(k-1)}{\lambda + x(k)^T R^{-1}(k-1)x(k)}$$

where $R^{-1}(k)$ stands for the inverse of the autocorrelation matrix of the string $x(k)$, symbol λ represents maximum value of the autocorrelation matrix eigenvector. The RLS algorithm is computationally more complex, but despite its computational complexity, it is more accurate and much faster, therefore, it is more suitable for use in a real-world environment such as a robotic arm environment.

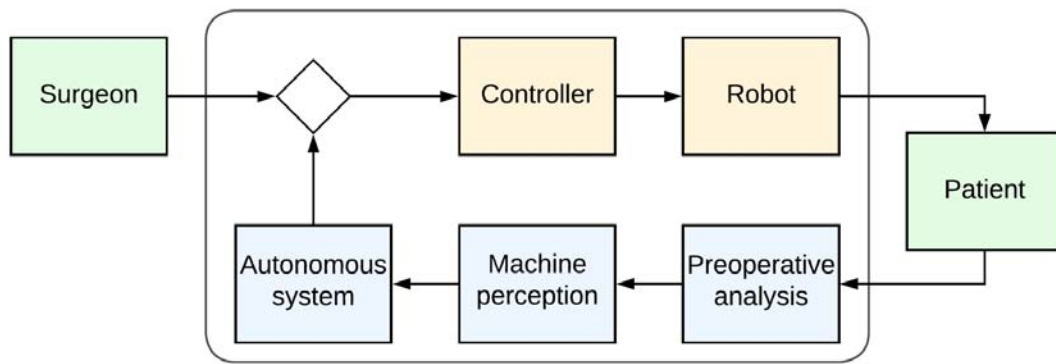

Figure 2: The System 3 level is capable of autonomously defining specifications for planning and performing a surgical task, while at level 2 all these specifications are determined by the surgeon /18/

The latest trend in management is the remote control of robots. These are operated by a human operator remotely. In remote work, despite new communication technologies such as 5G, there is a problem with the delay that occurs between the sensory feedback and the command that the remote operator gives to the manipulator. In order to overcome the delay dependence, the master-slave principle is introduced, which acts as a connector of two networks. With the advent of 6G communication technology, delays will be reduced to below 0.01ms, which will prevent unwanted interference when controlling the robot remotely.

c) AI and Data in Surgical Robotics

Artificial intelligence actually simulates human intelligence using algorithms that run on computers. Thus, computer-aided systems using artificial intelligence perform tasks that require an intelligent approach similar to that of a human. The use of artificial intelligence (AI) and machine learning (ML) in medicine is increasingly intensive, as the amount and availability of clinical data increases. With the approach of using AI and ML in medicine, we can perform complex data interpretation and identify non-linearities that are not immediately noticed by classical statistical techniques.

People often wonder why data is important at all. Data quality is extremely important when performing data analysis, whether it will be used for artificial intelligence or not. The quality of the data has two components:

1. Missing data
2. Incorrect information

Both components are highly problematic, and the impact of the difficulty of each component can only be determined on a case-by-case basis. If data quality is not taken into account in the process of machine learning a model, then the analysis of the model leads to wrong conclusions.

Traditionally, structured data is the basis for effective quantitative analysis. As we know from the theory of systems management, response in addition to

the properties of the system, the system depends on the signal at the input. Just as in machine learning, we also need data and AI; quality which means distinguishing between good and bad data. Bad data is a kind of noise, which causes the system output to respond incorrectly. These incorrect responses run the system, eg robot, in the wrong direction.

It also raises the question of what is the quality of the data? Here, the answer is subjective, as it depends on the field of application and methods of artificial intelligence. When parsing data sets we must pay attention to empty elements, or the indefinite element e of the data set. The data sets must consistently track the variables assigned to e.g. one v blood oxygen, another pressure, third temperature, etc. They must also be as perfect as possible, since we need to know the origin of data capture (sensor). We must trust these data sources, they must be accurate, but at the same time they must be valid. This means that data must be captured at the same time from other data sources.

Data accuracy is therefore key in model development, as in the application of AI methods. Because we collect data from different sources for system modeling, we must trust the data sources completely. If there are any virithat are not accurate, it will be our response distorted and you will not be able to get the correct answer. The data set must be valid, which is crucial for temporal data sets. The use of non-simultaneously captured givens may hinder the learning process, so we need a set of simultaneously captured givens.

At the same time, each piece of data must be unique and belong only to a certain set of variables i. For example, the oxygen data in the blood belongs only to one and not to several variables.

Quality and accurate givens we use them in operating theaters for simple support activities, as they can be used to recognize speech, visually detect objects, recognize patterns, and make appropriate decisions based on algorithms and recognized

parameters t_i . Artificial intelligence algorithms enable on-the-fly machine learning of natural language with real-time data capture, such as processing a, computer vision and and other data of vital functions. Based on this data and using AI and ML algorithms, robotic systems enable the automation of certain routine tasks and thus increase the efficiency of the entire surgical process.

As you can see, due to the nature of the work, surgery generates very large data sets that can be processed in detail and in depth using artificial intelligence methods. These data, in addition to those already mentioned, also include preoperative setup surgical data sets (patient clinical, laboratory, and imaging tests), intraoperative data only (based on video and kinematic data), and data sets including time, individual activities during the operation, the time of the entire operation, success rate of patient treatment and quality criteria of the performed procedure.

d) *Artificial Intelligence to Support Surgeons in Decision-Making*

Performing a classic operative intervention, the surgeon's decision-making is dominated primarily by hypothetical-deductive reasoning, his individual judgment and heuristics. Such decision-making can lead to bias, error, and preventable harm. Artificial intelligence with predictive analytics, as well as clinical decision support systems, are aimed at increasing the quality of surgeon decision-making. In cases of manual data capture and manual analysis by participating staff, the clinical utility of these data is compromised and thus the success of the intervention. The problem can be overcome by the real-time application of models and artificial intelligence on a set of data captured in real-time from electronic health devices and patient records. This approach requires standardization of data, advances in model interpretability, careful implementation and monitoring, attention to ethical challenges involving algorithm bias and liability for error, and retention of treatment performance status assessment and human intuition in the decision-making process.

Linking artificial intelligence to surgeon decision-making can improve the surgical process, subsequent care, identification and mitigation of risk factors, decisions about postoperative control, and shared decisions about the use of all resources.

Artificial intelligence is helpful for surgeons in the understanding and critical evaluation of the new surgical procedures, or research and development thereof. Obtaining good data to develop algorithms in medicine is expensive and time-consuming. The use of artificial intelligence in surgery itself, supported by methods of real-time recognition of the scene, service process, speech, etc., is developing more slowly than in other areas of medicine. The biggest reason is the

complexity of operations and thus mainly the lack of appropriate data structures, real-time capture during the implementation of the operative procedure.

As we have already mentioned, the use of artificial intelligence algorithms in surgical learning enables quality learning and training, such as preparing the surgical team for same surgery. With the introduction of simulation procedures based on deep learning and artificial intelligence, surgical training has undergone significant changes in all areas in recent years. Artificial intelligence is particularly useful for creating surgical simulations, allowing trainees to practice skills in a controlled environment and develop a better understanding of the complex task of surgery.

Looking at the advantages of operating simulators, we see them as an excellent way to teach trainee surgeons to established surgeons in a low-risk environment or when developing new techniques. Training surgeons with simulators reduces the number of risks, reducing errors during the procedure, thereby reducing the risks and mortality rate due to medical errors.

Studies have shown that students who use simulators perform better and retain more of what they learn than their counterparts who use more traditional methods of medical training. In fact, in one medical aptitude test, 20 students who used high-tech simulators far outperformed students who used traditional training /21/.

Compared to older methods, training with a simulator enables faster interventions, the presence of auxiliary staff is less and takes less time, the costs of the intervention are lower, and the probability of a successful intervention is disproportionately higher.

From that what has been said, we can see that artificial intelligence has a huge potential in the field of surgery, so the use of the mentioned methods together with simulators of surgical interventions it is necessary to include it in the daily work of surgeons. Considering the state of new technologies in surgery, it is necessary to expand medical study programs by teaching the mentioned methods, i.e. to familiarize students with the use of artificial intelligence and simulation procedures in healthcare and medical robotics. Medical education institutions must better prepare medical students for changing technologies, as well as for increasingly knowledgeable patients who are increasingly knowledgeable about their illnesses, than they once were. Doctors of the future must be prepared for this new reality. At the same time, it is necessary to encourage patients to be more responsible for their health.

e) *Surgical Robots in the Real World*

The fact that even in surgery the bodies are moving introduces additional complexity for the surgeon, let alone for the surgical robot. Some robots

that already show a certain level of autonomy can be used in operations for performing simple routine tasks. What is e.g. Tibia - tibia fixed, it's relatively easy to work with and doesn't move much once it's locked into place. Unfortunately, certain parts of the body are not so easy to fix in place. For example, muscles contract, stomachs rumble, brains wiggle, and lungs expand and contract even before the surgeon begins the operation. Although the surgeon obviously sees and feels that when these organs are moving, how does the robot know if his scalpel is in the right place or if the tissues have moved? The solution to such dynamic situations combine the use of cameras and sophisticated tracking of tissue movement software in real time. A person as a surgeon marks certain points on the tissue with drops of fluorescent glue and create markers that the robot can follow. At the same time, the camera system creates a 3-D model of the tissue using a grid of light points projected onto the area. With the support of the software, the robot sees changes in the projected network and thus perceives, i.e. "sees" the actual state that is before him.

Today, robots that observe human actions and learn from these actions, according to one of the ML algorithms. Based on this type of learning, robots already predict the actions of their human counterparts. This method of predictive control allows robots to proactively plan and execute actions based on anticipating the action of a human partner. / [15] Huang,

C. M., & Mutlu, B. Anticipatory Robot Control for Efficient Human-Robot Collaboration/. Research has proven that monitoring user actions helped to improve cooperation and the efficiency of task performance /16/. Robot manipulators thus more accurately perform tasks that are otherwise performed by humans, because humans are not limited by their intelligence, but rather by their physical strength. We overcome these kinds of problems with robots.

Over the years, much has been thought about the structure of the psychological characteristics of human-robot joint action. Among the various factors, perfectly coordinated action was also related to the formation of expectations

The actions of the first partner towards the second and also the consequent fulfillment of these expectations [14, 17].

Thus, robotic manipulators have become a standard application in surgical medicine, where management and also the harmony between surgeon and robot is well performed by AI-based programs.

f) *The state of development medical robots in Slovenia*

In Slovenia, we are still developing robots at the first level of autonomy, where the robot is able to provide physical assistance to the surgeon. The characteristic of surgical robots at the lowest level is that all management decisions are left to the surgeon.



Slika 3: Collaborative robot MOTOMAN, Yaskava Kočevje

In this direction, new collaborative robot development programs are also underway at Yaskava and Kočevje (picture 3), while the University of Ljubljana and the Jožef Stefan Institute are primarily engaged in research into rehabilitation robots. The development trends that we are pursuing in Slovenia are aimed at robotic systems that actively cooperate with the surgeon. This objective represents level 1 which actually provides active assistance to the surgeon. At this level, robots perform activities that affect the surgeon's intervention, which means limiting the movement of surgical instruments based on knowledge of the environment. Image sensors are important here, such as force sensors, which alert the surgeon to prohibited areas in advance. At this level, the robot responds to

the actions of the surgeon and has no control over the execution of individual steps of the surgical procedure.

It also continues to develop advanced robotic components such as mechatronic assemblies for robots, advanced sensor-based robotic control systems, smart robotic effectors, laser and vision systems in robotics.

The field of development of advanced robotic systems in Slovenia also includes cognitive robotic systems, advanced human-robot interfaces, two- and multi-handed robotic systems, robotic diagnostics, mobile robotic platforms, mini-, micro- and nano-robot systems, environmental, medical and agro robotics. We also devote a large part of our research to the field of advanced control of robotic systems,

2D and 3D robotic vision for adaptive robot control, advanced robotic learning, and collaborative and reconfigurable robotics. In view of the development of 5G and 6G communication technologies, we are also devoting ourselves to research into connecting robotic systems with the Internet of Things, as well as control systems in robotics.

IV. CONCLUSION

With the use of a smart robot, the surgeon's job will be much easier. Pthan the smart robot bwarns similar to a smart system in a car that looks for us drivers of road hazards, restrictions and the effects of the weather on the roads. Just as the driver focuses on the driving itself, the doctor will also focus on the problem itself, eg removal of cancer. Individual authors in the literature even claim that the use of a soft robot even reduced the need for anesthesia. Since there is still no possibility for the robot to be completely autonomous, today's partial autonomy technology is already a great help to surgeons around the world.

Today's robots are only used for simpler tasks, such as holding a camera, for monitoring vital functions, for understanding spoken language, and performing eg delivery of the instrument to the operator, etc. The plan also goes in this direction, developing a robot assistant in Slovenia that should help the surgeon change instruments when necessary.

Thus, robotic manipulators have become a standard application in surgical medicine, where management and also the harmony between surgeon and robot is well performed by AI-based programs.

If we conclude with thoughts about the future, we can conclude that robotic surgery has great advantages over classical surgery. The big advantage of robotic surgery over classical surgery is tudi tathat it enables surgery through smaller incisions, that it enables greater work precision, as the movements of the robotic arm are more precise than human ones, better visualization is enabled, as it enables insight into 3D high resolution and recognition of objects that are sometimes not visible to the naked eye. Because the surgeon performs surgery with a robotic arm, the surgeon can use very small jinstruments to perform surgery inside the body. Recovery after robotic surgery is much shorter. Depending on the type of procedure, the patient can get up soon, the hospital stay is shorter, the effect of anesthesia wears off faster, sometimes patients can easily return home the very next day after the procedure.

A big advantage of using a robot supported by artificial intelligence is the possible st študija virtual representation of the entire operation process, the study aof better solutions and the advance epreparation eof the entire team for the robot-assisted operation itself. Therefore, it makes sense to introduce super

specializations and to introduce study programs in the fields of radiology, artificial intelligence and medicine, simulation procedures, visualization and 3D printing, for example, of .bone implants or trenutnim potrebam modified instruments. All t ovrstnioprograms must be included tudi in the study program of a medical engineer, teh and tekom rednega študija medical students must also be informed about technology reviews. Le z izvrsnim poznavanjem problema in študija rešitev we will increase the quality and at the same time reduce the costs of treatment.

Thought:

"Medical staff and AI have to monitor a person even before the appearance of illness."

LITERATURE

1. Gomez G. Sabiston Textbook of Surgery. 17th ed. Philadelphia, Pa: Elsevier Saunders; 2004. Emerging Technology in surgery: informatics, electronics, robotics
2. <https://www.transparencymarketresearch.com/pres-release/>
3. Andrea Moglia, Konstantinos Georgiou, Evangelos Georgiou, Richard M. Satava, Alfred Cuschieri; A systematic review on artificial intelligence in robot-assisted surgery, International Journal of Surgery 95 (2021) 106151,
4. Polinski JM et al. (2016) J Gen Intern Med 31,269–275 3. Nesbitt TS et al. (2005). J RuralHealth 21, 79–85 4. Uscher-Pinesand Mehrotra A. (2014). HealthAff 33, 258–264 5. Grustam AS et al. (2018). ValueHealth 21, 772-782 6. Thygeson M et al, (2008). HealthAff 27, 1283–1292 7. Sussman A et al. (2013). Am J ManagCare 19, e148–e157 8. Baker LC et al. (2011). HealthAff 30, 1689–1697 9. Wicklund E. (2019). Thearticle is available at <https://mhealthintelligence.com/news/>.
5. HIMSS Analytics. (2017). <https://www.himssanalytics.org/sites/himssanalytics/files/>.
6. Hayhurst, Jason. (2017) www.researchgate.net/publication/315053361.
7. Munos B et al. (2016). Ann NY AcadSci 1375, 3-18 32. Borrelli AB et al. (2016).
8. <https://www.intel.com/content/dam/www/public/us/en/documents/white-papers/>.
9. Chiara Di Resta C et al. (2018). EJIFCC 29, 4–14 34. Morash M et al. (2019) J Pers Med.
10. Friend L et al. (2018). <https://assets.kpmg/content/dam/kpmg/xx/pdf/2018/08/direct-to-consumer-genetic-testing>.
11. Harvard Health Online. (2019). <https://www.health.harvard.edu/staying-healthy/should-you-get-a-home-genetic-test>.
12. I. Ahmed et al. (2020), International Journal of Wireless In formation Networks (2020) 27:4–17, <https://doi.org/10.1007/s10776-019-00468-119>. http

s://www.genome.gov/dna-day/15-for-15/direct-to-consumer-genomic-testing.

13. L. Maier-Hein, SS Vedula, S. Speidel, et al., Surgical data science for next generation interventions, Nature Biomedical Engineering volume 1, pages 691–696 (2017).
14. Riva, G. & Water worth, JA (2003). Presence and the Self: A cognitiveneuro science approach. Presence-Connect, 3(1), Retrieved from: <http://presence.cs.ucl.ac.uk/presenceconnect/articles/Apr2003/jwworthApr72003114532/jwworthpr72003114532.html> .
15. Huang, C. M., & Mutlu, B. Anticipatory Robot Control for Efficient Human-Robot Collaboration.
16. Hoffman, G., & Breazeal, C. (2007, March). Effect sofanticipatoryaction on human-robot teamwork.
17. efficiency, fluency, andperceptionof team. In Proceedings of the ACM/IEEE international conference on Human-robot interaction (pp. 1-8). ACM. -20 G. Knoblich and J. S. Jordan. Action coordination in groups and individuals: learning anticipatory control. Journal of Experimental Psychology: Learning, Memory, and Cognition, 29(5):1006–1016, September 2003.
18. Aleks Attanasio, BrunoScaglioni, Elena De Momi, Paolo Fiorini, Pietro Valdastri; Autonomy in Surgical Robotics, Materials Science Annu. Rev. Control. Robotics Auton. Syst., May 2021.
19. <https://www.cio.com/article/234837/supercharge-healthcare-with-artificial-intelligence.html>
20. <https://www.cio.com/article/234837/supercharge-healthcare-with-artificial-intelligence.html>
21. 4 Best Free Surgery Simulators for Medical Professionals | Capterra.



GLOBAL JOURNAL OF MEDICAL RESEARCH: I
SURGERIES AND CARDIOVASCULAR SYSTEM
Volume 24 Issue 1 Version 1.0 Year 2024
Type: Double Blind Peer Reviewed International Research Journal
Publisher: Global Journals
Online ISSN: 2249-4618 & Print ISSN: 0975-5888

Impact of the use of Probiotics in Bariatric Patients in Promoting Weight Loss and Maintenance. A Systematic Review

By Larissa Gabrielle Dias Dos Santos, Silvana Aparecida Samora
& Mônica Fernandez

São Camilo University

Abstract- Objective: To analyze the impact of using probiotic supplements on weight maintenance in post-bariatric surgery patients.

Method: Research in magazines and websites that compile scientific articles, including Scielo, Pubmed, CAPES. This systematic review provided scientific coverage in Portuguese and English, with a period limited from 2018 to 2023, with inconclusive articles being discarded.

Results: 9 articles from randomized controlled studies, systematic reviews and meta-analyses were selected. The total number of patients: 1011, aged over 18 years, with supplementation for at least 15 days and maximum 12 months.

Discussion: Probiotic supplementation was beneficial for improving lipid, glycemic and vitamin profiles, reducing inflammatory markers, binge eating symptoms and anthropometric markers of adiposity.

Keywords: "obesity", "bariatric surgery", "intestinal dysbiosis", "probiotic supplementation".

GJMR-I Classification: NLM: WI 900



IMPACT OF THE USE OF PROBIOTICS IN BARIATRIC PATIENTS IN PROMOTING WEIGHT LOSS AND MAINTENANCE AS SYSTEMATIC REVIEW

Strictly as per the compliance and regulations of:



RESEARCH | DIVERSITY | ETHICS

Impact of the use of Probiotics in Bariatric Patients in Promoting Weight Loss and Maintenance. A Systematic Review

Impacto Do Uso De Probióticos Em Pacientes Bariátricos Na Promoção Da Perda E Manutenção Do Peso. Uma Revisão Sistemática

Larissa Gabrielle Dias Dos Santos ^α, Silvana Aparecida Samora ^ο & Mônica Fernandez ^ρ

Abstract- Objective: To analyze the impact of using probiotic supplements on weight maintenance in post-bariatric surgery patients.

Method: Research in magazines and websites that compile scientific articles, including Scielo, Pubmed, CAPES. This systematic review provided scientific coverage in Portuguese and English, with a period limited from 2018 to 2023, with inconclusive articles being discarded.

Results: 9 articles from randomized controlled studies, systematic reviews and meta-analyses were selected. The total number of patients: 1011, aged over 18 years, with supplementation for at least 15 days and maximum 12 months.

Discussion: Probiotic supplementation was beneficial for improving lipid, glycemic and vitamin profiles, reducing inflammatory markers, binge eating symptoms and anthropometric markers of adiposity. The supplementation period with the best responses is 3 months post-surgery. Starting before surgery can bring better results.

Conclusion: The use of probiotics can help maintain weight in post-operative bariatric surgery patients. Possibly, probiotic supplementation promotes a better quality of life for its users. However, more studies are needed.

Keywords: "obesity", "bariatric surgery", "intestinal dysbiosis", "probiotic supplementation".

Resumo- Objetivo: Analisar o impacto do uso de suplementos probióticos na manutenção do peso de pacientes pós-operatórios de cirurgia bariátrica. **Método:** Pesquisas em revistas e sites compiladores de artigos científicos, sendo eles Scielo, Pubmed, Capes. Esta revisão sistemática conferiu abrangência científica na língua portuguesa e inglesa, com período delimitado de 2018 até 2023, sendo descartados artigos inconclusivos.

Resultados: Foram selecionados 9 artigos de estudos randomizados controlados, revisões sistemáticas e meta-análises. O número total de pacientes: 1011, idade superior a 18 anos, com suplementação de no mínimo 15 dias máximo de 12 meses.

Author α: Graduanda do Curso de Pós-Graduação em Nutrição Clínica do Centro Universitário São Camilo. São Paulo, SP.

e-mails: larissasantosnrc@gmail.com, silvana_samora@hotmail.com

Author ρ: Hospital Irmandade da Santa Casa de Misericórdia de São Paulo/Centro Universitário São Camilo – Orientação de TCC. São Paulo, SP. e-mail: mf001973@gmail.com

Discussão: A suplementação probiótica foi benéfica para melhora do perfil lipídico, glicêmico e vitamínico, redução de marcadores inflamatórios, de sintomas de compulsão alimentar e de marcadores antropométricos de adiposidade. O período de suplementação com melhores respostas é de 3 meses pós-operatório. Iniciar antes da cirurgia pode trazer melhores resultados.

Conclusão: O uso de probióticos pode auxiliar na manutenção de peso em pacientes pós-operatórios de cirurgia bariátrica. Possivelmente, suplementação probiótica promove maior qualidade de vida a seus usuários. Entretanto, mais estudos se fazem necessários.

Palavras-chave: "obesidade", "cirurgia bariátrica", "disbiose intestinal", "suplementação de probiótico".

1. INTRODUÇÃO

A obesidade é caracterizada como acúmulo de gordura corporal excessivo. Esse estado nutricional é classificado quando o Índice de Massa Corporal (IMC) é maior ou igual a 30 Kg/m². Segundo Khanna *et al.* (2022) obesidade é uma doença crônica de etiologia multifatorial, que inclui influências socioeconômicas, genéticas, psicológicas e ambientais. Além disso, é o principal fator de risco para doenças cardiovasculares, diabetes e alguns tipos de neoplasia. (OMS, 2020). Referente a epidemiologia, em 2023 foi estimado que, no Brasil, 34,51% da população adulta tem sobrepeso. Em relação a obesidade grau I, o percentual é de 20,71%. (BRASIL, 2023). As cirurgias para perda de peso no tratamento de obesidade proporcionam maior eficácia em seus resultados. Atualmente, são recomendadas para indivíduos de 18 a 65 anos com IMC maior ou igual a 40 kg/m² ou 35 kg/m² com uma ou mais comorbidades graves relacionadas a obesidade, além de relatório de equipe multidisciplinar comprovando que o paciente não perdeu ou não manteve a perda de peso por no mínimo, 2 anos. (ABESO, 2016). O acompanhamento por equipe multidisciplinar e recomendado, para a redução dos riscos perioperatórios e obtenção dos melhores resultados. (EISENBERG *et al.*, 2022). O estudo de Costa *et al.* (2019) sugere que pacientes em

pós operatório desse tipo de cirurgia apresentam sintomas de disbiose, caracterizada pelo desequilíbrio na composição do microbioma gastrointestinal. Essa alteração pode causar doenças inflamatórias intestinais e diabetes tipo 2, além de desencadear sinalizações celulares pró-inflamatórias. O uso de probióticos pode ser promissor para promover o equilíbrio da microbiota intestinal. Ademais, sua suplementação está relacionada a melhoras cognitivas e associadas ao estresse, considerando o eixo microbiota-intestino-cérebro. (KIM *et al.*, 2020). Outros estudos também indicam que essa suplementação, quando realizada no pós-operatório, pode diminuir sintomas de compulsão alimentar e reduzir biomarcadores antropométricos de adiposidade a longo prazo, consequentemente auxiliando na manutenção de peso corporal. (CARLOS *et al.*, 2022). (PEDRET *et al.*, 2018). Tendo em vista algumas complicações que podem ocorrer no pós-operatório desta cirurgia, como carências nutricionais, desequilíbrio da microbiota intestinal, dificuldade na manutenção do peso corporal e sintomas de desconforto gastrointestinal (KARBASCHIAN *et al.*, 2018), verifica-se a necessidade de pesquisar sobre o uso de suplementação de probióticos na contribuição da manutenção da perda de peso.

II. OBJETIVO

Analisar o impacto do uso de suplementos probióticos na perda e manutenção do peso de pacientes pós-operatórios de cirurgia bariátrica.

III. MÉTODO

Para este estudo foram realizadas pesquisas em revistas e sites compiladores de artigos científicos,

sendo eles Scielo, Pubmed, Capes. Esta revisão sistemática conferiu uma abrangência científica na língua portuguesa e inglesa, com o período delimitado referente a 2018 até 2023, sendo descartados artigos inconclusivos ou incompletos.

IV. RESULTADOS

Para este estudo, foram selecionados 9 artigos (tabela 1). Dentre esses artigos, 7 são estudos randomizados controlados e 2 são revisão sistemática e meta-análise de ensaios randomizados. O número total de pacientes: 1011, com idade superior a 18 anos, com uso de probióticos no mínimo, 15 dias e, no máximo, 12 meses. Além disso, alguns estudos iniciaram a suplementação anteriormente ao procedimento cirúrgico. Os gêneros das cepas utilizadas incluem *Bifidobacterium*, *Lactobacillus*, *Lactococcus* e *Streptococcus*, entre outros não identificados. Os aspectos avaliados abrangem sintomas de compulsão alimentar; perfil lipídico, glicêmico e vitamínico; marcadores inflamatórios; marcadores antropométricos de adiposidade; marcadores relacionados a Doença Hepática Gordurosa Não Alcoólica (DHGNA); perda de peso corporal; status ou níveis séricos de vitamina D; elevação da proteína de ligação de lipopolissacarídeos (LBP); desenvolvimento de supercrescimento bacteriano no intestino delgado (SIBO) no pós-operatório imediato; circunferência da cintura; percentual de perda de excesso de peso (%PEP); índice de massa corporal (IMC).

Tabela 1: Descrição Dos Estudos Que Compõem Essa Revisão Sistemática

Autor. Ano.	Desenho De Estudo	N. De Pacientes /Idade/ Tempo Do Estudo	Tipo De Probiótico	Desfecho
PEDRET et al. 2018.	Ensaio randomizado, paralelo, duplo-cego e controlado por placebo.	n.135 maiores de 18 anos. 3 meses.	<i>Bifidobacterium animaliss</i> ubsp. <i>lactis</i> CECT 8145 (Ba8145) e sua cepa na forma <i>heat-killed</i> (h-k).	Na presença de obesidade abdominal, o uso de Ba8145 e h-k Ba8145 melhora os biomarcadores antropométricos de adiposidade, principalmente em mulheres.
KARBASCHIAN et al. 2018.	Ensaio clínico randomizado, duplo-cego, controlado por placebo.	n.45 18 a 60 anos. 4 semanas antes e até 12 semanas pós-operatório	<i>Lactobacillus casei</i> ; <i>rhamn-osus</i> ; <i>bulgaricus</i> ; <i>acidophilus</i> . <i>Bifidobacterium breve</i> ; <i>long-um</i> . <i>Streptococcus thermo-philus</i> .	A suplementação de probióticos melhora os marcadores inflamatórios, a perda de peso corporal e o status da vitamina D em pacientes submetidos a cirurgia.

MOKHTARI et al. 2019.	Ensaio clínico randomizado, duplo-cego, controlado por placebo.	n.45 18 a 60 anos. 4 semanas antes e até 12 semanas pós-operatório	<i>Lactobacillus casei</i> ; <i>rhamnosus</i> ; <i>bulgaricus</i> ; <i>acidophilus</i> . <i>Bifidobacterium breve</i> ; <i>longum</i> . <i>Streptococcus thermophilus</i> .	Suplementação probiótica durante 4 meses comparado com placebo inibiram a elevação da proteína de ligação de lipopolissacarídeos (LBP) e melhoraram os níveis séricos de TNF- α , vitamina D3 25OH e perda de peso.
WAGNER et al. 2020.	Estudo prospectivo, randomizado, duplo-cego, controlado por placebo.	n.73 18 a 59 anos 90 dias.	<i>Lactobacillus acidophilus</i> NCFM e <i>Bifidobacteriumlactis</i> Bi-07.	A suplementação de <i>L. acidophilus</i> e <i>B. lactis</i> é eficaz na redução do inchaço, mas sem influenciar no desenvolvimento de supercrescimento bacteriano no intestino delgado (SIBO) no pós-operatório imediato.
RAMOS et al. 2021.	Ensaio clínico randomizado, duplo-cego, controlado por placebo.	n.101 90 dias.	<i>Lactobacillus acidophilus</i> NCFM e <i>Bifidobacteriumlactis</i> Bi-07.	A suplementação de probióticos após a cirurgia melhora o perfil vitamínico e lipídico.
ZHANG et al. 2021.	Revisão sistemática e meta-análise de ensaios randomizados controlados.	n.172 maiores de 18 anos. 15 dias; 4 meses; 6 meses.	<i>Lactobacillus acidophilus</i> ; <i>casei</i> ; <i>paracasei</i> ; <i>plantarum</i> . <i>Bifidobacteriumbifidum</i> ; <i>hamnosus</i> ; <i>breve</i> ; <i>longum</i> ; <i>infantis</i> . <i>Lactococcuslactis</i> . <i>Streptococcus thermophiles</i> .	Redução da circunferência da cintura após cirurgia bariátrica, mas sem efeito significativo no peso, IMC, percentual de perda de excesso de peso (%PEP) e PCR.
ROMMEN et al. 2021.	Estudo randomizado, duplo-cego e controlado.	n.60 20 a 65 anos. 12 semanas.	<i>Lactobacillus acidophilus</i> ; <i>delbrueckii</i> susp. <i>bulgaricus</i> ; <i>helveticus</i> ; <i>plantarum</i> ; <i>rhamnosus</i> ; <i>casei</i> . <i>Bifidobacterium breve</i> ; <i>longum</i> ; <i>lactis</i> susp. <i>lactis</i> . <i>Streptococcus thermophiles</i> .	A suplementação com uma mistura especificamente adaptada de probióticos e micronutrientes melhorou os marcadores relacionados à DHGNA mais do que a mistura básica de micronutrientes em pacientes obesos após cirurgia bariátrica.
DAGHMOURI et al. 2022.	Revisão sistemática e meta-análise de estudos clínicos randomizados controlados.	n.279 18 a 60 anos. De 12 semanas a 1 ano.	<i>Lactobacillus acidophilus</i> NCFM; <i>casei</i> ; <i>rhamnosus</i> ; <i>bulgaricus</i> ; <i>paracasei</i> LPC-37. <i>Bifidobacteriumlactis</i> Bi-07; <i>lactis</i> HN019; <i>breve</i> ; <i>longum</i> . <i>Streptococcus thermophilus</i> .	Os probióticos na cirurgia bariátrica garantem melhor perfil lipídico e glicêmico sem efeito nas medidas antropométricas e marcadores inflamatórios.
CARLOS et al. 2022.	Estudo randomizado duplo-cego controlado por placebo.	n.101 18 a 59 anos. 90 dias.	<i>Lactobacillus acidophilus</i> NCFM. <i>Bifidobacteriumlactis</i> Bi-07.	A utilização de suplemento probiótico pós-operatório pode diminuir os sintomas de compulsão alimentar um ano após a cirurgia.

V. DISCUSSÃO

Nos artigos avaliados, o ensaio clínico de Karbaschian *et al.* (2018) identificou melhora nos marcadores inflamatórios, status de vitamina D e perda de peso corporal com a suplementação de probióticos realizada durante 4 semanas pré-operatório e até 12 semanas após o procedimento cirúrgico. Entretanto, o estudo de Mokhtari *et al.* (2019) concluiu que essa estratégia específica foi favorável para a perda de peso, assim como melhorou os níveis séricos de vitamina D, TNF- α e inibiu a elevação de LBP, porém, por período limitado. Ademais, a revisão de Zhang *et al.* (2021) infere que a suplementação com determinadas cepas de *Lactobacillus*, *Bifidobacterium*, *Lactococcus* e *Streptococcus* pelo período de 4 a 6 meses após a cirurgia auxilia na diminuição da circunferência da cintura, mas não tem efeito significativo na perda de peso, melhora do IMC, %PEP e PCR. A meta-análise de Daghmouri *et al.* (2022) verificou que o uso de probióticos por 12 semanas a 1 ano pós-operatório promove a melhora do perfil lipídico e glicêmico, mas não ocasiona mudanças relevantes nas medidas antropométricas e indicadores inflamatórios. Todavia, Pedret *et al.* (2018) conclui em seu ensaio clínico randomizado que a suplementação probiótica durante 3 meses melhora os biomarcadores antropométricos de adiposidade em indivíduos com obesidade. Além disso, Ramos *et al.* (2021) afirma que essa estratégia pós-operatório melhora o perfil vitamínico e lipídico. Para mais, Carlos *et al.* (2022) conclui em seu estudo randomizado que suplementar probióticos durante 90 dias pós-operatório pode atenuar sintomas de compulsão alimentar 1 ano após o procedimento cirúrgico. Com relação ao desenvolvimento de SIBO no pós-operatório imediato, o estudo de Wagner *et al.* (2020) identificou que essa ação não o influencia, apesar de diminuir o inchaço de forma eficaz. No que se refere a marcadores relacionados a Doença Hepática Gordurosa Não Alcoólica (DHGNA), Crommen *et al.* (2021) infere que a suplementação com uma mistura especificamente adaptada de probióticos e micronutrientes promove melhora desses indicadores. Com isso, pode-se verificar que, dentre esses pontos avaliados, os únicos que não tiveram resposta positiva a suplementação com probióticos incluem %PEP e desenvolvimento de SIBO. Todos os outros aspectos manifestaram resposta positiva, principalmente quando a suplementação foi iniciada 1 mês pré-operatório e/ou ocorreu durante 3 meses pós-operatório. Entretanto, alguns deles manifestaram resposta positiva por tempo limitado. Dentre as cepas utilizadas, destacam-se *Bifidobacterium breve*, *Bifidobacterium lactis* Bi-07, *Bifidobacterium longum*, *Lactobacillus acidophilus*, *Lactobacillus acidophilus* NCFM, *Lactobacillus bulgaricus*, *Lactobacillus casei*, *Lactobacillus*

rhamnosus, *Streptococcus thermophilus*. Pois essas foram as que apareceram com mais frequência nos tópicos verificados que manifestaram resposta positiva a suplementação. Tendo em vista o desfecho dos estudos selecionados, verifica-se que é provável que o uso de probióticos possa auxiliar na perda e manutenção e de peso corporal no pós-operatório de cirurgia bariátrica. Além disso, alguns aspectos podem ser beneficiados com a suplementação probiótica, como perfil lipídico, glicêmico e vitamínico, marcadores inflamatórios, status de vitamina D, compulsão alimentar, marcadores relacionados a DHGNA e marcadores antropométricos de adiposidade. Para fins de comparação, foi observado que o estudo de Suzumura *et al.* (2019) concluiu que a suplementação oral com probióticos ou simbióticos tem um pequeno efeito na redução da circunferência da cintura, mas nenhum efeito no peso corporal ou no IMC. Já a revisão de Cook *et al.* (2020) alegou que as intervenções probióticas não tem influência significativa qualidade de vida ou na perda de peso corporal após a cirurgia bariátrica. Inclusive, a meta-análise realizada por Wang *et al.* (2022) relatou que essa suplementação não ocasiona efeito significativo em marcadores inflamatórios, perfil lipídico ou %PEP. Entretanto, a revisão e meta-análise de Wang *et al.* (2023) constatou que probióticos podem retardar a progressão da lesão da função hepática, melhorar o metabolismo lipídico, reduzir o peso e reduzir a ingestão de alimentos, pois tiveram um efeito benéfico em indicadores como aspartato aminotransferase, triglicérides, peso corporal, ingestão alimentar e vitamina B12. Com isso, tendo em vista a análise dos artigos selecionados e as comparações realizadas, conclui-se que o uso de probióticos pode vir a ser vantajoso para atenuar diversos fatores que são consequências do quadro de obesidade e favorecer o controle de peso de pacientes em pós-operatório. Ainda assim, mais estudos se fazem necessários para comprovar essas premissas.

VI. CONCLUSÃO

A suplementação com probióticos em pacientes submetidos a cirurgia bariátrica pode auxiliar na manutenção e perda de peso após o procedimento. Ademais, também pode ser benéfica para auxiliar no tratamento de vários fatores que são consequências da obesidade. Entretanto, mais estudos se fazem necessários para comprovar essa hipótese, para investigar as respostas dos pacientes ao longo do uso e aprimorar as condutas de suplementação.

REFERENCES RÉFÉRENCES REFERENCIAS

1. ABESO - Associação Brasileira para o Estudo da Obesidade e da Síndrome Metabólica. *Diretrizes*

- brasileiras de obesidade 2016*. São Paulo: ABESO, 2016. 188 p. Disponível em: <https://abeso.org.br/wp-content/uploads/2019/12/Diretrizes-Download-Diretrizes-Brasileiras-de-Obesidade-2016.pdf>. Acesso em: 23 jun. 2023.
2. BRASIL. Relatórios de Acesso Público [Internet]. SISVAN - Sistema de Vigilância Alimentar e Nutricional. Secretaria de Atenção Primária à Saúde, 2023. Disponível em: <https://sisaps.saude.gov.br/sisvan/relatoriopublico>. Acesso em: 23 jun. 2023.
 3. CARLOS, L. O. *et al.* Probiotic supplementation attenuates binge eating and food addiction 1 year after roux-en-y gastric bypass: a randomized, double-blind, placebo-controlled trial. *ABCD. Arquivos Brasileiros de Cirurgia Digestiva (São Paulo)*, v. 35, 2022. Disponível em: <https://doi.org/10.1590/0102-672020210002e1659>. Acesso em: 26 jun. 2023.
 4. COOK, J. *et al.* Gut microbiota, probiotics and psychological states and behaviors after bariatric surgery — a systematic review of their interrelation. *Nutrients*, v. 12, n. 8, p. 2396, 10 ago. 2020. Disponível em: <https://doi.org/10.3390/nu12082396>. Acesso em: 19 fev. 2024.
 5. COSTA, D. A. L. *et al.* Prevalência de sinais e sintomas de disbiose intestinal em indivíduos obesos atendidos em uma instituição de ensino de Brasília-DF. *Revista Brasileira de Obesidade, Nutrição e Emagrecimento*, v. 13, n. 80, p. 488-497, maio 2019. Disponível em: <https://www.rbone.com.br/index.php/rbone/article/view/1006/699>. Acesso em: 23 jun. 2023.
 6. CROMMEN, S. *et al.* A specifically tailored multistrain probiotic and micronutrient mixture affects nonalcoholic fatty liver disease—related markers in patients with obesity after mini gastric bypass surgery. *The Journal of Nutrition*, v. 152, n. 2, p. 408-418, 22 nov. 2021. Disponível em: <https://doi.org/10.1093/jn/nxab392>. Acesso em: 27 jun. 2023.
 7. DAGHMOURI, M. A. *et al.* Probiotics in bariatric surgery ensure greater lipids and glycemic profile with no effect on anthropometric measurements and inflammatory markers: A systematic review and meta-analysis of RCT. *Surgery Open Digestive Advance*, v. 7, p. 100061, set. 2022. Disponível em: <https://doi.org/10.1016/j.soda.2022.100061>. Acesso em: 27 jun. 2023.
 8. EISENBERG, D. *et al.* 2022 American Society for Metabolic and Bariatric Surgery (ASMBS) and International Federation for the Surgery of Obesity and Metabolic Disorders (IFSO): Indications for Metabolic and Bariatric Surgery. *Surgery for Obesity and Related Diseases*, out. 2022. Disponível em: <https://doi.org/10.1016/j.soard.2022.08.013>. Acesso em: 23 jun. 2023.
 9. KARBASCHIAN, Z. *et al.* Probiotic supplementation in morbid obese patients undergoing one anastomosis gastric bypass-mini gastric bypass (OAGB-MGB) surgery: a randomized, double-blind, placebo-controlled, clinical trial. *Obesity Surgery*, v. 28, n. 9, p. 2874-2885, 3 maio 2018. Disponível em: <https://doi.org/10.1007/s11695-018-3280-2>. Acesso em: 26 jun. 2023.
 10. KHANNA, D.; WELCH, B. S.; REHMAN, A. *Pathophysiology of obesity*. Treasure Island: StatPearls [Internet], 2022. E-book (13 p.). Disponível em: <https://www.ncbi.nlm.nih.gov/books/NBK572076/>. Acesso em: 20 jun. 2023.
 11. KIM, C. *et al.* Probiotic supplementation improves cognitive function and mood with changes in gut microbiota in community-dwelling older adults: a randomized, double-blind, placebo-controlled, multicenter trial. *The Journals of Gerontology: Series A*, v. 76, n. 1, p. 32-40, 17 abr. 2020. Disponível em: <https://doi.org/10.1093/gerona/glaa090>. Acesso em: 26 jun. 2023.
 12. MOKHTARI, Z. *et al.* The effects of probiotic supplements on blood markers of endotoxin and lipid peroxidation in patients undergoing gastric bypass surgery; a randomized, double-blind, placebo-controlled, clinical trial with 13 months follow-up. *Obesity Surgery*, v. 29, n. 4, p. 1248-1258, 5 jan. 2019. Disponível em: <https://doi.org/10.1007/s11695-018-03667-6>. Acesso em: 27 jun. 2023.
 13. PEDRET, A. *et al.* Effects of daily consumption of the probiotic *Bifidobacterium animalis* subsp. *lactis* CECT 8145 on anthropometric adiposity biomarkers in abdominally obese subjects: a randomized controlled trial. *International Journal of Obesity*, v. 43, n. 9, p. 1863-1868, 27 set. 2018. Disponível em: <https://doi.org/10.1038/s41366-018-0220-0>. Acesso em: 26 jun. 2023.
 14. RAMOS, M. R. Z. *et al.* Effects of *Lactobacillus acidophilus* NCFM and *Bifidobacterium lactis* Bi-07 supplementation on nutritional and metabolic parameters in the early postoperative period after roux-en-y gastric bypass: a randomized, double-blind, placebo-controlled trial. *Obesity Surgery*, v. 31, n. 5, p. 2105-2114, 14 jan. 2021. Disponível em: <https://doi.org/10.1007/s11695-021-05222-2>. Acesso em: 27 jun. 2023.
 15. SUZUMURA, E. A. *et al.* Effects of oral supplementation with probiotics or synbiotics in overweight and obese adults: a systematic review and meta-analyses of randomized trials. *Nutrition Reviews*, v. 77, n. 6, p. 430-450, 28 mar. 2019. Disponível em: <https://doi.org/10.1093/nutrit/nuz001>. Acesso em: 19 fev. 2024.
 16. WAGNER, N. R. F. *et al.* Effects of probiotics supplementation on gastrointestinal symptoms and SIBO after roux-en-y gastric bypass: a prospective,

randomized, double-blind, placebo-controlled trial. *Obesity Surgery*, 11 ago. 2020. Disponível em: <https://doi.org/10.1007/s11695-020-04900-x>. Acesso em: 27 jun. 2023.

17. WANG, Y. *et al.* Effects of probiotics in patients with morbid obesity undergoing bariatric surgery: a systematic review and meta-analysis. *International Journal of Obesity*, 6 set. 2023. Disponível em: <https://doi.org/10.1038/s41366-023-01375-5>. Acesso em: 26 fev. 2024.
18. WANG, Y.; WU, X.; CHEN, J. Effect of probiotic supplementation on weight loss, inflammatory factors, and metabolic effects in patients undergoing bariatric surgery. *Obesity Surgery*, v. 32, n. 5, p. 1779-1782, 4 mar. 2022. Disponível em: <https://doi.org/10.1007/s11695-022-05974-5>. Acesso em: 25 fev. 2024.
19. WHO – World Health Organization. *Obesity and overweight*. Disponível em: <https://www.who.int/news-room/fact-sheets/detail/obesity-and-overweight>. Acesso em: 20 jun. 2023.
20. ZHANG, Y. *et al.* Probiotics can further reduce waist circumference in adults with morbid obesity after bariatric surgery: a systematic review and meta-analysis of randomized controlled trials. *Evidence-Based Complementary and Alternative Medicine*, v. 2021, p. 1-10, 1 abr. 2021. Disponível em: <https://doi.org/10.1155/2021/5542626>. Acesso em: 27 jun. 2023.





GLOBAL JOURNAL OF MEDICAL RESEARCH: I
SURGERIES AND CARDIOVASCULAR SYSTEM
Volume 24 Issue 1 Version 1.0 Year 2024
Type: Double Blind Peer Reviewed International Research Journal
Publisher: Global Journals
Online ISSN: 2249-4618 & Print ISSN: 0975-5888

Chest Wall Reconstruction with Expanded Polytetrafluoroethylene Mesh in Pediatric Patient. Chest Wall Reconstruction with Mesh

By Edgar Melo Camacho

Introducción- El tratamiento quirúrgico como la resección de tumores pulmonares, mediastínicos u óseos que afectan la integridad de la pared torácica y su reconstrucción primaria del defecto originado continúan siendo un reto en el paciente pediátrico (1). Si bien, existe gran difusión de la reconstrucción con materiales protésicos rígidos en el tratamiento quirúrgico, el riesgo de infección y alteración en el desarrollo y crecimiento son mayores.

GJMR-I Classification: NLM: WO 640



Strictly as per the compliance and regulations of:



Chest Wall Reconstruction with Expanded Polytetrafluoroethylene Mesh in Pediatric Patient.

Chest Wall Reconstruction with Mesh

Reconstrucción de Pared Torácica con Malla de Politetrafluoroetileno Expandido en Paciente Pediátrico. Reconstrucción Torácica con Malla

Edgar Melo Camacho

I. INTRODUCCIÓN

El tratamiento quirúrgico como la resección de tumores pulmonares, mediastínicos u óseos que afectan la integridad de la pared torácica y su reconstrucción primaria del defecto originado continúan siendo un reto en el paciente pediátrico (1). Si bien, existe gran difusión de la reconstrucción con materiales protésicos rígidos en el tratamiento quirúrgico, el riesgo de infección y alteración en el desarrollo y crecimiento son mayores.

II. REPORTE DE CASOS

Presentamos el caso de 2 pacientes tratadas quirúrgicamente con resección amplia de tumor mediastinal con compromiso de pared torácica y su reconstrucción con malla de Politetrafluoroetileno expandido (Sarcoma de Ewing metastásico y Tumor de Askin respectivamente).

El primer paciente es un femenino de 7 años con antecedente de traumatismo contuso en región costal derecha, astenia y adinamia, y pérdida ponderal. Se realiza tomografía axial computarizada con evidencia de imagen heterogénea con origen en espacio prevertebral de C7-T10, extensión foraminal, y 2º a 5º arcos costales derechos en su cabeza articular y ángulo costal. Se realiza toma de biopsia por aguja la cual reporta Sarcoma de Ewing CD99 (+) y FLI1(+), iniciando neoadyuvancia por 6 semanas y posterior evaluación de respuesta al tratamiento con PET-CT, observando lesión en hemitórax derecho de contornos irregulares y dimensiones de 3.5x4 cm dependiente de cabeza articular y cuerpo de 2º y 5º arcos costales (Figura 1). Se realiza toracotomía posterolateral derecha con incisión a nivel de 6º espacio intercostal, logrando palpar e identificar tumoración torácica que se extiende desde 2ª hasta 5ª cabezas articulares y ángulos costales (Figura 2). Se realiza costectomía de 2º a 5º arcos costales para la resección total de tumoración y asegurar borde libre de 2 cm (Figura 3). Se identifican lesiones metastásicas en segmento 4 de pulmón

derecho y se realiza enucleación para metastasectomía. Previa colocación por contra abertura de sonda endopleural derecha 20 fr, se coloca malla de politetrafluoroetileno expandido (Gore-Tex), el cual abarca una dimensión aproximada de 8 x 7 cm, fijando con puntos simples de Prolene 3-0 a parrilla costal y complejo muscular intercostal (Figura 4). Se realiza afrontamiento costal con Ethibond y cierre de plano muscular y aponeurosis con Vicryl 3-0 y piel con punto subdérmico de Monocryl 3-0. Cursa durante postquirúrgico inmediato con ventilación mecánica invasiva por 24 horas, tolerando extubación sin complicaciones. Continúa monitorización continua con oximetría de pulso, sin identificar alteración en patrón respiratorio, con vigilancia de función ventilatoria mediante oximetría de pulso y gasometría. Se corrobora con radiografía de tórax situación de sonda pleural, sin identificar evidencia de derrame pleural o neumotórax, logrando retiro de sonda a las 72h sin complicaciones. Continua seguimiento y vigilancia, sin evidencia de alteración en la mecánica ventilatoria y sin datos clínicos sugestivos de escoliosis.

El segundo caso, es masculino de 8 años, con antecedente y diagnóstico de Tumor de Askin. Se realiza toracotomía posterolateral izquierda por tumoración con involucro de parrilla costal (4º, 5º y 6º arcos costales). Se realiza incisión a nivel de 5º espacio intercostal y disección hasta identificar tumoración. Se realiza costectomía de arcos costales 4º a 6º para asegurar resección en bloque y bordes libres. Se afrontan arcos costales y se coloca malla de politetrafluoroetileno expandido (malla de Gore-Tex) en defecto de aproximadamente 5 x8cm (Figura 5). Se coloca sonda endopleural 20 fr y se cierra plano muscular y aponeurótico. Cursa postquirúrgico inmediato con adecuada evolución, logrando extubación programada sin complicaciones. Manteniendo vigilancia y monitorización de mecánica ventilatoria por oximetría de pulso, gasometría y signos vitales. Se envían ambas piezas quirúrgicas a patología confirmando diagnóstico prequirúrgico (Sarcoma de

Author: e-mail: edgarmelocamacho@hotmail.com

Ewing y Tumor de Askin respectivamente) y reportando bordes libres de tumor.

III. DISCUSIÓN

La estrategia y técnica de reconstrucción de la pared torácica posterior a la resección de tumoraciones que comprometen su integridad continúa siendo controvertido. La decisión de tratamiento quirúrgico amerita un manejo multidisciplinario y se basa en principios fundamentales como: reconstrucción torácica y reparación de tejidos blandos adyacente (2). El tratamiento se debe enfocar en la resección del tumor primario con bordes macroscópicos libres, debridación del tejido adyacente necrótico o desvitalizado, reconstrucción torácica inmediata y definitiva que permita una estabilidad torácica y función pulmonar adecuada.

Existen múltiples alternativas de reconstrucción de pared torácica en el paciente pediátrico, los cuales se basan fundamentalmente en la técnica quirúrgica (tejido autólogo o colgajo muscular) y material protésico empleado (mallas, prótesis cerámicas o prótesis metálicas) ideal para lograr una estabilidad estructural (3). El material protésico para emplearse debe ser lo suficientemente maleable para adaptarse a la forma de la pared torácica, lo suficientemente rígido para otorgar estabilidad y preservar su función, proteger los órganos vitales intratorácicos, no alergénico, durable, no carcinogénico, radiolúcido y capaz de adaptarse al crecimiento del niño (4).

Si bien, el uso de material protésico rígido como los compuestos de titanio otorgan una estabilidad estructural cercana a la normalidad, cuentan con la desventaja de comprometer la estética y función a largo plazo al no adaptarse al crecimiento y desarrollo del paciente pediátrico (5). En cambio, el uso de mallas flexibles permite una distensibilidad torácica que preserva la función pulmonar; sin embargo, esta misma ventaja podría ocasionar escoliosis en pacientes con resección amplia (6).

La complejidad en la planeación y toma de decisiones en la reconstrucción torácica posterior a una resección tumoral se basa en los tipos de abordaje con incisiones amplias como Clamshell, Hemi-Clamshell, "U", "L" o transesternales (7). Es importante tomar en cuenta el sitio, tamaño, localización (anterior, anterolateral, posterolateral) y estructuras anatómicas involucradas en la planeación quirúrgica (esternón, escápula, número de costillas). Se ha reportado que, en áreas de resección menores a 5 cm, la técnica de reconstrucción con tejidos blandos es suficiente (flap muscular, técnica de sándwich). Sin embargo, los defectos mayores de 5cm ameritan un reforzamiento estructural rígido (8). Dentro de los materiales rígidos, los más utilizados son prótesis de metilmetacrilato, silicón y titanio, estos otorgan la ventaja de asegurar

estabilidad de la pared torácica, evitando así problemas de la función respiratoria. Sin embargo, las desventajas de su uso son el mayor riesgo de infección, seroma, ruptura, desplazamiento y no acoplamiento al crecimiento torácico. De los materiales no rígidos como parches y mallas existen los sintéticos (Polipropileno, Politetrafluoroetileno y Vicryl), y los biológicos (aloinjertos o material bioprotésico, pericardio bovino). Las ventajas de su uso recaen en la facilidad en su manipulación, sutura y menor reacción a cuerpo extraño con consecuente incidencia menor de infección (9,10).

En cuanto al material de elección para reconstrucción de pared torácica, se ha demostrado que el uso de malla sintética ha tenido resultados favorables en el postquirúrgico inmediato y mediato, siendo un método seguro y reproducible (11,12).

El sarcoma de Ewing, es el tumor de tórax más frecuente en la población pediátrica. Se caracteriza por su alto grado de malignidad, metástasis y recurrencia local. El tratamiento se basa en control local con resección amplia que aseguren en medida de lo posible márgenes libres de hasta 1-2cm; para lograrlo, en ocasiones es necesario reseca estructuras óseas como costillas o esternón, siendo un factor crítico para supervivencia (13).

El uso de mallas biológicas o sintéticas continúa ganando popularidad entre los procedimientos en pacientes adultos; existen pocos reportes en la literatura de su uso en pacientes pediátricos (14).

IV. CONCLUSIONES

Los tumores de pared torácica son poco frecuentes en la población pediátrica siendo el Sarcoma de Ewing el tumor con mayor incidencia. El tratamiento consiste en la resección amplia; sin embargo, las estructuras comprometidas obligan a planear la reconstrucción de pared torácica. Es conocido en la literatura el uso de prótesis rígidas en defectos grandes (>5cm) para estabilizar la pared torácica. Dentro de sus desventajas se contempla la dificultad para acceder al recurso en la atención pública, afectar el desarrollo y crecimiento en la población pediátrica y su alta incidencia de infección en sitio quirúrgico. Presentamos el caso de 2 pacientes con resección y reconstrucción torácica con malla de Politetrafluoroetileno expandido como una alternativa ampliamente conocida, factible y reproducible, siendo un material accesible, seguro y con resultados aceptables en términos de estabilidad torácica y baja incidencia de infección de herida o sitio quirúrgico.

REFERENCES RÉFÉRENCES REFERENCIAS

1. Al-Qattan M., Hajjar W. Reconstruction of an anterior chest wall defect in a child using a latissimus dorsi muscle-thoraco-lumbar fascia composite flap – A case report. *Int J Surg Case Rep.* 2020;72:290-293.

2. Huang S., Chen C., Qiu P., Yan Z., Chen W., Liang Z., et al. Reconstruction of complex chest wall defects: A case report. *World J Clin Cases*. 2022 Apr 16;10(11):3505-3510.
 3. Hameed A., Akhtar S., Naqvi A., Pervaiz Z. Reconstruction of complex chest wall defects by using polypropylene mesh and a pedicled latissimus dorsi flap: a 6-year experience. *J Plast Reconstr Aesthet Surg*. 2008 Jun;61(6):628-35.
 4. Sandler G., Haydes-Jordan A. Chest wall reconstruction after tumor resection. *Semin Pediatr Surg*. 2018 Jun;27(3):200-206.
 5. Makarawo T., Reynolds R., Cullen M. Polylactide bioabsorbable struts for chest wall reconstruction in a pediatric patient. *Ann Thorac Surg*. 2015 Feb;99(2):689-91.
 6. Wang L., Yan X., Zhao J., Chen C., Chen J., Cao T., et al. Expert consensus on resection of chest wall tumors and chest wall reconstruction. *Transl Lung Cancer Res*. 2021 Nov;10(11):4057-4083.
 7. André-Lévigne D., Modarressi A., Karenovics W., Joseph J., Wild J., Pittet-Cuénod M. Operative Planning of Chest Wall Reconstructions Illustrated by a Large Defect in a Child. *Plast Reconstr Surg Glob Open*. 2022 May 13;10(5):e4326.
 8. Shah N., Ayyala H., Tran B., Therattil P., Keith J. Outcomes in Chest Wall Reconstruction Using Methyl Methacrylate Prostheses: A Review of the Literature and Case Series Utilizing a Novel Approach with Biologic Mesh. *J Reconstr Microsurg*. 2019 Oct;35(8):575-586.
 9. Colella S., Brandimarte A., Marra R., et al. Chest wall reconstruction in benign and malignant tumors with non-rigid materials: An overview. *Front Surg*. 2022 Aug 3;9:976463.
 10. Theodorou C., Lawrence Y., Brown E. Chest wall reconstruction in pediatric patients with chest wall tumors: A systematic review. *J Pediatr Surg*. 2023 Jul;58(7):1368-1374.
 11. Schroeder-Finckh A., Lopez-Pastorini A., Galetin T., Defosse J., Stoelben E., Koryllos A. Anterior Chest Wall Reconstruction Using Polypropylene Mesh: A Retrospective Study. *Thorac Cardiovasc Surg*. 2020 Jun;68(4):341-351.
 12. Guillén G., García L, Marhuenda C., Pellise F., Molino J.A., Fontecha C.G., López S., Lloret J. Thoracic wall reconstruction with bioabsorbable plates in pediatric malignant thoracic wall tumors. *J Pediatr Surg*. 2017 Mar;52(3):377-381. D
 13. Shamberger R., Grier H. Ewing's sarcoma/primitive neuroectodermal tumor of the chest wall. *Semin Pediatr Surg*. 2001.
 14. Maistry N., Durell J., Wilson S., Lakhoo K. Primary paediatric chest wall tumours necessitating surgical management. *Ann R Coll Surg Engl*. 2020 May; 102(5):335-339.
- Figura 1. Tomografía axial computarizada con evidencia de invasión costal.
- Figura 2. Toracotomía posterolateral derecho con exposición de tumor.
- Figura 3. Costectomía y segmentectomía no anatómica.
- Figura 4. Colocación de Malla de Politetrafluoroetileno expandido (Gore-Tex).
- Figura 5. Colocación de malla de politetrafluoroetileno expandido.

This page is intentionally left blank



GLOBAL JOURNAL OF MEDICAL RESEARCH: I
SURGERIES AND CARDIOVASCULAR SYSTEM
Volume 24 Issue 1 Version 1.0 Year 2024
Type: Double Blind Peer Reviewed International Research Journal
Publisher: Global Journals
Online ISSN: 2249-4618 & Print ISSN: 0975-5888

Massive Haemo Thorax Following Ultrasound-Guided Central Venous Catheterization in an Anaesthetised Patient: A Case Report

By Dr Parli Raghavan Ravi & Dr Hilal Ali Hamed Al Rashdi

Abstract- Central venous catheterization is a commonly performed procedure in operation theatre. After the advent of ultrasound (US)guided central venous catheterization (CVC), the incidence of life-threatening complications has reduced significantly and are rare. We present a case of haemothorax in a young patient after US guided which was inserted at the end of surgery under anaesthesia. The operator had some technical difficulty while inserting the CVC. The Haemothorax was diagnosed post-operatively in the ward after was missed clinically by radiological investigation. It was treated by inserting a 36 Fr chest drain on the second post-operative day which was removed on the seventh postoperative day and the patient was discharged to home.

Keywords: *ultrasound, central venous catheterization, haemothorax.*

GJMR-I Classification: *NLMC Code: WO 51*



Strictly as per the compliance and regulations of:



Massive Haemo Thorax Following Ultrasound-Guided Central Venous Catheterization in an Anaesthetised Patient: A Case Report

Dr Parli Raghavan Ravi ^α & Dr Hilal Ali Hamed Al Rashdi ^σ

Abstract- Central venous catheterization is a commonly performed procedure in operation theatre. After the advent of ultrasound (US)guided central venous catheterization (CVC), the incidence of life-threatening complications has reduced significantly and are rare. We present a case of haemothorax in a young patient after US guided which was inserted at the end of surgery under anaesthesia. The operator had some technical difficulty while inserting the CVC. The Haemothorax was diagnosed post-operatively in the ward after was missed clinically by radiological investigation. It was treated by inserting a 36 Fr chest drain on the second post-operative day which was removed on the seventh postoperative day and the patient was discharged to home.

Keywords: ultrasound, central venous catheterization, haemothorax.

I. INTRODUCTION

Central venous catheterization is one of the most common invasive interventions performed in anesthesia and critically ill patients¹. It can be associated with many complications. The vascular complications being common, can be both extra-thoracic, such as damage to the carotid artery which is easily detected and controlled with manual compression. The intrathoracic vascular injuries are not only difficult to diagnose and control but can be life-threatening. Hemothorax, albeit a rare complication is a dangerous one and can cause fatal outcomes. The advent of ultrasound and its use for accessing the central lines dramatically reduces the complications secondary to the procedure. However, there is still no guarantee of safety since the real-time observations of the guidewire insertion, dilator, and catheter tip insertion and its course are not impossible^{2,3}.

We present here a case of massive hemothorax after central line insertion, under ultrasound guidance, which was inserted at the end of surgery and was diagnosed in the post-operative ward.

II. CASE REPORT

A 27-year-old, 51kg patient with a BMI of 20.2, a diagnosed case of Non-Seminoma Germ cell tumor was

Author α: Senior Consultant (Anaesthesiology), Sultan Qaboos Comprehensive Cancer Care and Research Centre, Muscat, Oman. e-mail: parliravi@gmail.com

Author σ: Senior Consultant (Uro Oncology), Sultan Qaboos Comprehensive Cancer Care and Research Centre, Muscat, Oman

posted for retroperitoneal lymph node dissection (RPLND) with residual mass excision. He had no history of any chronic metabolic disease. All the preoperative blood (Hb 13.4 mg%) and radiological investigations had no significant findings. Monitors in the form of NIBP, ECG, and oxygen saturation were attached to the patient. An epidural catheter was placed in the T6-7 intra-spinous space for post-operative analgesia. The patient was premedicated with Inj. Fentanyl 100 micrograms intravenous (i.v), Inj Dexamethasone 8 mg i.v. He was induced with Inj. propofol 100mg and a 7.4 mm ETT was passed after administering 50 mg of Rocuronium. He was maintained on oxygen, air, and desflurane. After induction and intubation of the patient, an arterial line was placed in the left radial artery for blood pressure monitoring. A temperature probe was placed in the oropharynx. Intraoperatively the haemodynamic course was normal. The surgery lasted for about 6 hours. Since the venous access was poor, it was decided that a central venous line would be placed in the right internal jugular. At the end of the surgery, after repositioning the patient, a central venous catheter (CVC) was placed using ultrasound (Philips USG machine) guidance. The puncture of the vein was made under ultrasound guidance. There was some resistance in passing the guidewire. The guidewire was pulled out and the process was repeated. The operator did a smooth insertion of the guidewire and then passed the CVC over the guidewire. The central venous catheter was fixed at the 15 cm mark and was confirmed fluoroscopically. Blood was aspirable only in two of the three ports of the CVC. The patient was then extubated and sent to the post-anesthesia care unit (PACU). The last arterial blood gas was within normal limits. The total blood loss was 300 ml. At the time of discharge from the PACU to the ward the vitals were stable (HR 68/min, NIBP 110/76 mm of Hg, oxygen saturation 100% on room air, ECG WNL). Two hours after the patient was shifted to the ward there was a fall in the blood pressure (NIBP 90/60 mm of Hg). The patient was given a bolus of 500 ml of RL and the epidural infusion was reduced from 6 ml (0.125 percent Bupivacaine) to 4 ml. However, the patient persisted in having intermittent episodes of hypotension, which responded to boluses of fluid and small doses (3mg of ephedrine) of vasoconstrictors. The abdominal drains placed during the surgery had a

minimal amount of slightly blood-tinged fluid. All the boluses were given in the peripheral line. On postoperative day 1 patient hemoglobin fell to 6 grams percent and the patient remained hypotensive, however responsive to fluid bolus and inotropes. However, the abdomen was soft on examination. On auscultation, there was apparent decreased air entry on the right side of the chest. Two units of cross-matched blood were transfused. After 48 hours, the patient stabilized hemodynamically. The patient had an oxygen saturation of 92 to 94 % with the facemask O₂ of 2-3L/min. So an ultrasound abdomen/chest and chest X-ray were done. Chest X-ray revealed a massive hemothorax of the right lung (Fig 1) and it was confirmed on CT scan too (Fig 2). A 36 size chest tube was placed and it drained almost 1.4 liters of blood. The haemothorax resolved completely (Fig 3). The patient was given one more unit of blood. The central line was removed on the 3rd post-operative day and compression was given. The patient's hemodynamics stabilized. On day 7 postoperative day, the patient developed a low-grade fever of 37.8C. The patient was sent to the opinion of a cardiothoracic surgeon and was later discharged from the ward after the removal of the chest tube after 07 days. The hemothorax had completely resolved at the time of discharge.

III. DISCUSSION

The neck and the thoracic inlet have a complex network of major vessels. Hence Hemothorax can occur during the insertion of CVC when the intrathoracic artery or vein is damaged or perforated by the dilator, guidewire, or catheter².

The earliest and the most important sign of any vascular injury is hypotension, which is sudden and unexpected. In our case, the diagnosis of hemothorax was delayed. Probably the reason was that the hypotension did not occur immediately and the patient responded to boluses of fluid and small doses of vasoconstrictor, which clouded the decision of the clinician. Early diagnosis of hemothorax requires a high degree of suspicion and aggressive clinical and radiological examination of the patient, especially when the surgical drains are not draining commiserating blood^{3,4}. We should have performed the portable X-ray or USG at the first instance of hypotension. Studies have shown that a bedside USG can diagnose the hemothorax faster than the X-Ray.

While inserting the CVC, the operator always predicts the entry of the needle and the catheter into the central vein by aspirating the blood. However, even aspiration of the blood is not always an assurance that the catheter is properly placed⁴. It must be presumed that when one of the ports is not aspirating blood, the catheter might be misplaced or is inappropriately located. In our case, we were not able to aspirate blood

from one of the ports and hence it should have been considered a red flag in our case.

The introduction of ultrasound has dramatically reduced the incidence of vascular injury. Multiple studies have reported almost nil to low incidence of vascular complications after using USG. However, there are some reports of injury to the right subclavian artery (RCA) and right and left Brachiocephalic veins (BCV)^{2,5}. The US guidance will always help in adjusting the insertion point and the depth of the vessel to avoid injury, however, there are some reports of vascular injuries, although few under US guidance also. Ultrasound guidance will not help prevent intrathoracic vascular injuries due to dilator, guidewire, or catheter insertion inside the thorax⁵. If the damage is in the arterial vessel, the deterioration of the vital signs will be rapid and can be a fatal event, in comparison to venous structures, where the clinical deterioration is slow and may even be missed or diagnosed late^{5,6}. Arterial injuries may require immediate thoracic exploration. In our patient most likely it was a venous injury of the thoracic vessel either of the right IJV or RT BCV.

Multiple mechanisms can be postulated while dwelling upon the literature for the possible mechanism of the injury in our case of BCV. Damage to IJV is rare as it is usually supraclavicular and can be easily made out by the US. Firstly, there is always a possibility of the guidewire from the right IJV advancing into the wrong vessel, such as into the right subclavian (SCV), azygous, or even left BCV causing injury to the vessels^{5,6,7}. Although the proximal part of the guidewire will be within the IJV, that does not guarantee the distal part of it to be in the proper position in the thorax. This can especially be disastrous if the dilator is inserted with force after the guidewire has damaged the SCV. Forceful insertion of guidewire, hence, should never be done. In our case, the operator had got resistance in the first attempt. It is quite possible that in the second attempt when the dilator was inserted over the guidewire, it could have damaged the right SCV. Secondly, the dilator should never be inserted below the clavicle. It should be used to dilate the subcutaneous space only. A forceful and deep insertion of the dilator can damage the right BCV directly.

There is a two-step safety procedure described for Central venous catheterization. Firstly, both the short-axis and long view should be done for the real-time puncture of the needle insertion into the IJV^{3,5}. The second is to verify the position of the guidewire in the BCV using a short axis and coronal view. This will help to detect the malposition of guidewire in the BCV^{3,5}.

IV. CONCLUSION

The possibility of damaging the vascular structure exists during the insertion of CVC even though ultrasound is being used for guidance. It is important to

aspirate to come out of all ports. It is also desirable that adequate knowledge of the technique is available when doing real-time guidance of the insertion of CVC. The guidewire, dilator, and catheter all are potent sources to cause damage to the intra-thoracic vascular structure. A high degree of clinical suspicion of hemothorax should be there in case of hypotension occurs in a patient with recent insertion of CVC as venous bleeding may trickle and cause massive haemothorax slowly without causing much clinical deterioration. Haemothorax developing on the same side, where the CVC has been established should be attributed to CVC until proven otherwise.

REFERENCES RÉFÉRENCES REFERENCIAS

1. Engin OZAKIN, Rumeysa CAN, Nurdan ACAR, Filiz BALOGLU KAYA, Arif Alper CEVIK. An Evaluation of Complications in Ultrasound-Guided Central Venous Catheter Insertion in the Emergency department. Turk J Emerg Med 2014; 14(2):53-58. doi: 10.5505/1304.7361.2014.93275.
2. Jeong Heon Park , Jaegyok Song , Pyeong-wha Oh. Massive hemothorax after central venous catheter insertion in a patient with multiple trauma. J Dent Anesth Pain Med 2021; 21(1):81-85. <https://doi.org/10.17245/jdapm.2021.21.1.81>
3. Saugel B, Scheeren TWL, Teboul JL. Ultrasound-guided central venous catheter placement: a

- structured review and recommendations for clinical practice. Crit Care. 2017; 21:225. <https://doi.org/10.1186/s13054-017-1814-y>.
4. Jony E. Dib, MD, Rim A. Boutari, MD, Boshra A. Yaacoub, MD, Nayef A. Al Khalil, MD, Mohamad A. Al Ayoubi, MD², Othman S. Itani, MD³. Hemothorax Occurring After Central Venous Catheter Removal: A Case Report. . Int J Clin Res (2022), Volume 3, Issue 1. DOI: <https://doi.org/10.38179/ijcr.v3i1.123>
5. Tao-wu Gong, Yu-hang Zhu¹, Peng-cheng Zhao and Fan Zhang. Massive hemothorax secondary to internal jugular vein central venous catheter placement in a patient undergoing spinal surgery complicated by chest trauma: a case report. Journal of Cardiothoracic Surgery (2023) 18:104. <https://doi.org/10.1186/s13019-023-02194-5>.
6. Ketan Vagholkar, Yash Kriplani, Shivangi Garima. Delayed Haemothorax due to indwelling right internal jugular vein central venous catheterization. American Journal of Medical case reports 2019, Vol 17, No.4, 56-58. DOI:10.12691/ajmcr-7-4-1
7. Zeiler J, Idell S, Norwood S, Cook A. Hemothorax: A Review of the Literature. Clin Pulm Med. 2020;27(1):1-12. PMID: 33437141. <https://doi.org/10.1097/CPM.0000000000000343>.

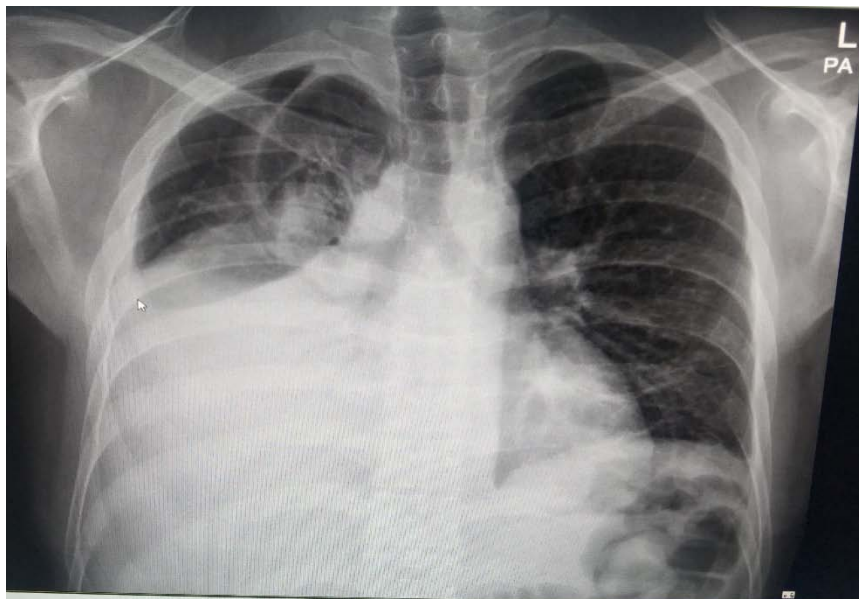

Figure 1: Chest X-Ray Left side Massive Hemothorax

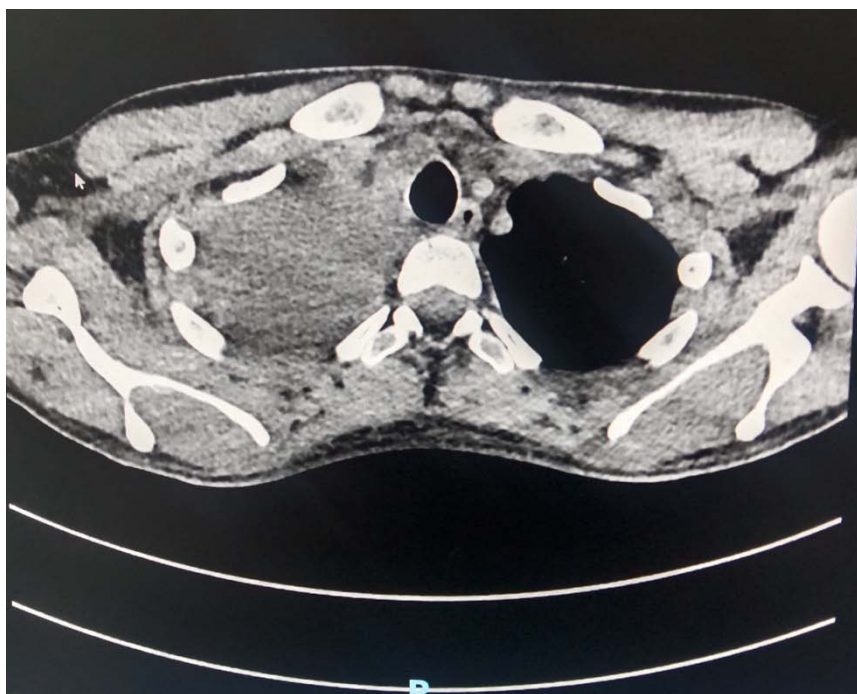

Figure 2: CT Scan showing the massive Hemothorax

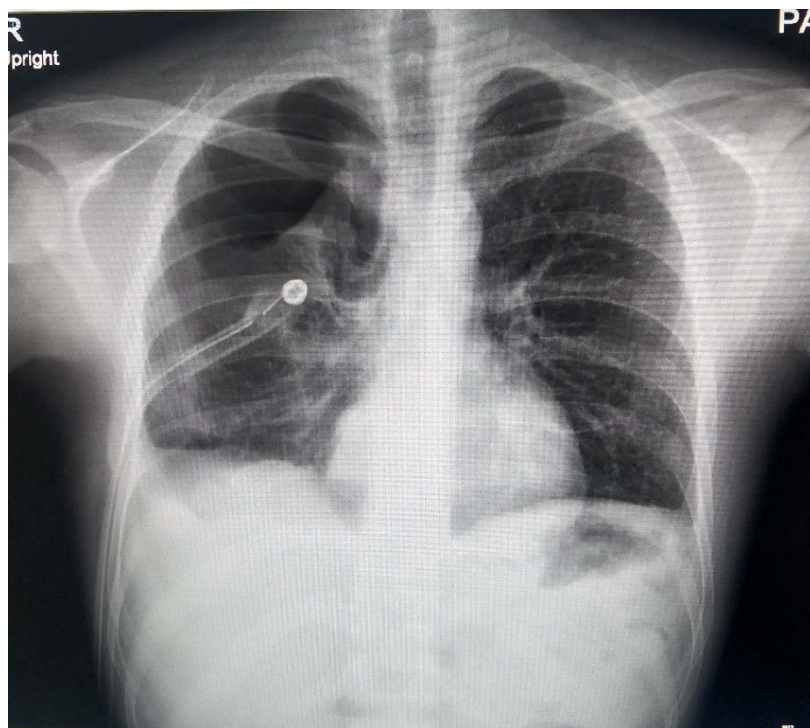

Figure 3: Complete Resolution of the haemothorax



GLOBAL JOURNALS GUIDELINES HANDBOOK 2024

WWW.GLOBALJOURNALS.ORG

MEMBERSHIPS

FELLOWS/ASSOCIATES OF MEDICAL RESEARCH COUNCIL

FMRC/AMRC MEMBERSHIPS

INTRODUCTION



FMRC/AMRC is the most prestigious membership of Global Journals accredited by Open Association of Research Society, U.S.A (OARS). The credentials of Fellow and Associate designations signify that the researcher has gained the knowledge of the fundamental and high-level concepts, and is a subject matter expert, proficient in an expertise course covering the professional code of conduct, and follows recognized standards of practice. The credentials are designated only to the researchers, scientists, and professionals that have been selected by a rigorous process by our Editorial Board and Management Board.

Associates of FMRC/AMRC are scientists and researchers from around the world are working on projects/researches that have huge potentials. Members support Global Journals' mission to advance technology for humanity and the profession.

FMRC

FELLOW OF MEDICAL RESEARCH COUNCIL

FELLOW OF MEDICAL RESEARCH COUNCIL is the most prestigious membership of Global Journals. It is an award and membership granted to individuals that the Open Association of Research Society judges to have made a 'substantial contribution to the improvement of computer science, technology, and electronics engineering.

The primary objective is to recognize the leaders in research and scientific fields of the current era with a global perspective and to create a channel between them and other researchers for better exposure and knowledge sharing. Members are most eminent scientists, engineers, and technologists from all across the world. Fellows are elected for life through a peer review process on the basis of excellence in the respective domain. There is no limit on the number of new nominations made in any year. Each year, the Open Association of Research Society elect up to 12 new Fellow Members.



BENEFITS

TO THE INSTITUTION

GET LETTER OF APPRECIATION

Global Journals sends a letter of appreciation of author to the Dean or CEO of the University or Company of which author is a part, signed by editor in chief or chief author.



EXCLUSIVE NETWORK

GET ACCESS TO A CLOSED NETWORK

A FMRC member gets access to a closed network of Tier 1 researchers and scientists with direct communication channel through our website. Fellows can reach out to other members or researchers directly. They should also be open to reaching out by other.

Career

Credibility

Exclusive

Reputation



CERTIFICATE

CERTIFICATE, LOR AND LASER-MOMENTO

Fellows receive a printed copy of a certificate signed by our Chief Author that may be used for academic purposes and a personal recommendation letter to the dean of member's university.

Career

Credibility

Exclusive

Reputation



DESIGNATION

GET HONORED TITLE OF MEMBERSHIP

Fellows can use the honored title of membership. The "FMRC" is an honored title which is accorded to a person's name viz. Dr. John E. Hall, Ph.D., FMRC or William Walldroff, M.S., FMRC.

Career

Credibility

Exclusive

Reputation

RECOGNITION ON THE PLATFORM

BETTER VISIBILITY AND CITATION

All the Fellow members of FMRC get a badge of "Leading Member of Global Journals" on the Research Community that distinguishes them from others. Additionally, the profile is also partially maintained by our team for better visibility and citation. All fellows get a dedicated page on the website with their biography.

Career

Credibility

Reputation

FUTURE WORK

GET DISCOUNTS ON THE FUTURE PUBLICATIONS

Fellows receive discounts on the future publications with Global Journals up to 60%. Through our recommendation programs, members also receive discounts on publications made with OARS affiliated organizations.

Career

Financial



GJ INTERNAL ACCOUNT

UNLIMITED FORWARD OF EMAILS

Fellows get secure and fast GJ work emails with unlimited storage of emails that they may use them as their primary email. For example, john [AT] globaljournals [DOT] org.

Career

Credibility

Reputation



PREMIUM TOOLS

ACCESS TO ALL THE PREMIUM TOOLS

To take future researches to the zenith, fellows receive access to all the premium tools that Global Journals have to offer along with the partnership with some of the best marketing leading tools out there.

Financial

CONFERENCES & EVENTS

ORGANIZE SEMINAR/CONFERENCE

Fellows are authorized to organize symposium/seminar/conference on behalf of Global Journal Incorporation (USA). They can also participate in the same organized by another institution as representative of Global Journal. In both the cases, it is mandatory for him to discuss with us and obtain our consent. Additionally, they get free research conferences (and others) alerts.

Career

Credibility

Financial

EARLY INVITATIONS

EARLY INVITATIONS TO ALL THE SYMPOSIUMS, SEMINARS, CONFERENCES

All fellows receive the early invitations to all the symposiums, seminars, conferences and webinars hosted by Global Journals in their subject.

Exclusive





PUBLISHING ARTICLES & BOOKS

EARN 60% OF SALES PROCEEDS

Fellows can publish articles (limited) without any fees. Also, they can earn up to 70% of sales proceeds from the sale of reference/review books/literature/publishing of research paper. The FMRC member can decide its price and we can help in making the right decision.

Exclusive

Financial

REVIEWERS

GET A REMUNERATION OF 15% OF AUTHOR FEES

Fellow members are eligible to join as a paid peer reviewer at Global Journals Incorporation (USA) and can get a remuneration of 15% of author fees, taken from the author of a respective paper.

Financial

ACCESS TO EDITORIAL BOARD

BECOME A MEMBER OF THE EDITORIAL BOARD

Fellows and Associates may join as a member of the Editorial Board of Global Journals Incorporation (USA) after successful completion of three years as Fellow and as Peer Reviewer.

Career

Credibility

Exclusive

Reputation

AND MUCH MORE

GET ACCESS TO SCIENTIFIC MUSEUMS AND OBSERVATORIES ACROSS THE GLOBE

All members get access to 5 selected scientific museums and observatories across the globe. All researches published with Global Journals will be kept under deep archival facilities across regions for future protections and disaster recovery. They get 10 GB free secure cloud access for storing research files.

ASSOCIATE OF MEDICAL RESEARCH COUNCIL

ASSOCIATE OF MEDICAL RESEARCH COUNCIL is the membership of Global Journals awarded to individuals that the Open Association of Research Society judges to have made a 'substantial contribution to the improvement of computer science, technology, and electronics engineering.

The primary objective is to recognize the leaders in research and scientific fields of the current era with a global perspective and to create a channel between them and other researchers for better exposure and knowledge sharing. Members are most eminent scientists, engineers, and technologists from all across the world. Associate membership can later be promoted to Fellow Membership. Associates are elected for life through a peer review process on the basis of excellence in the respective domain. There is no limit on the number of new nominations made in any year. Each year, the Open Association of Research Society elect up to 12 new Associate Members.



BENEFITS

TO THE INSTITUTION

GET LETTER OF APPRECIATION

Global Journals sends a letter of appreciation of author to the Dean or CEO of the University or Company of which author is a part, signed by editor in chief or chief author.



EXCLUSIVE NETWORK

GET ACCESS TO A CLOSED NETWORK

A AMRC member gets access to a closed network of Tier 2 researchers and scientists with direct communication channel through our website. Associates can reach out to other members or researchers directly. They should also be open to reaching out by other.

Career

Credibility

Exclusive

Reputation



CERTIFICATE

CERTIFICATE, LOR AND LASER-MOMENTO

Associates receive a printed copy of a certificate signed by our Chief Author that may be used for academic purposes and a personal recommendation letter to the dean of member's university.

Career

Credibility

Exclusive

Reputation



DESIGNATION

GET HONORED TITLE OF MEMBERSHIP

Associates can use the honored title of membership. The "AMRC" is an honored title which is accorded to a person's name viz. Dr. John E. Hall, Ph.D., AMRC or William Walldroff, M.S., AMRC.

Career

Credibility

Exclusive

Reputation

RECOGNITION ON THE PLATFORM

BETTER VISIBILITY AND CITATION

All the Associate members of AMRC get a badge of "Leading Member of Global Journals" on the Research Community that distinguishes them from others. Additionally, the profile is also partially maintained by our team for better visibility and citation.

Career

Credibility

Reputation

FUTURE WORK

GET DISCOUNTS ON THE FUTURE PUBLICATIONS

Associates receive discounts on future publications with Global Journals up to 30%. Through our recommendation programs, members also receive discounts on publications made with OARS affiliated organizations.

Career

Financial

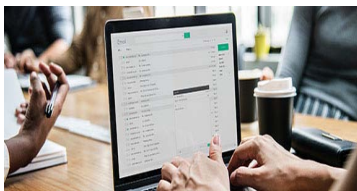

GJ ACCOUNT

UNLIMITED FORWARD OF EMAILS

Associates get secure and fast GJ work emails with 5GB forward of emails that they may use them as their primary email. For example, john [AT] globaljournals [DOT] org.

Career

Credibility

Reputation



PREMIUM TOOLS

ACCESS TO ALL THE PREMIUM TOOLS

To take future researches to the zenith, fellows receive access to almost all the premium tools that Global Journals have to offer along with the partnership with some of the best marketing leading tools out there.

Financial

CONFERENCES & EVENTS

ORGANIZE SEMINAR/CONFERENCE

Associates are authorized to organize symposium/seminar/conference on behalf of Global Journal Incorporation (USA). They can also participate in the same organized by another institution as representative of Global Journal. In both the cases, it is mandatory for him to discuss with us and obtain our consent. Additionally, they get free research conferences (and others) alerts.

Career

Credibility

Financial

EARLY INVITATIONS

EARLY INVITATIONS TO ALL THE SYMPOSIUMS, SEMINARS, CONFERENCES

All associates receive the early invitations to all the symposiums, seminars, conferences and webinars hosted by Global Journals in their subject.

Exclusive





PUBLISHING ARTICLES & BOOKS

EARN 60% OF SALES PROCEEDS

Associates can publish articles (limited) without any fees. Also, they can earn up to 30-40% of sales proceeds from the sale of reference/review books/literature/publishing of research paper

Exclusive

Financial

REVIEWERS

GET A REMUNERATION OF 15% OF AUTHOR FEES

Associate members are eligible to join as a paid peer reviewer at Global Journals Incorporation (USA) and can get a remuneration of 15% of author fees, taken from the author of a respective paper.

Financial

AND MUCH MORE

GET ACCESS TO SCIENTIFIC MUSEUMS AND OBSERVATORIES ACROSS THE GLOBE

All members get access to 2 selected scientific museums and observatories across the globe. All researches published with Global Journals will be kept under deep archival facilities across regions for future protections and disaster recovery. They get 5 GB free secure cloud access for storing research files.





ASSOCIATE	FELLOW	RESEARCH GROUP	BASIC
<p>\$4800 lifetime designation</p> <hr/> <p>Certificate, LoR and Momento 2 discounted publishing/year Gradation of Research 10 research contacts/day 1 GB Cloud Storage GJ Community Access</p>	<p>\$6800 lifetime designation</p> <hr/> <p>Certificate, LoR and Momento Unlimited discounted publishing/year Gradation of Research Unlimited research contacts/day 5 GB Cloud Storage Online Presense Assistance GJ Community Access</p>	<p>\$12500.00 organizational</p> <hr/> <p>Certificates, LoRs and Momentos Unlimited free publishing/year Gradation of Research Unlimited research contacts/day Unlimited Cloud Storage Online Presense Assistance GJ Community Access</p>	<p>APC per article</p> <hr/> <p>GJ Community Access</p>



PREFERRED AUTHOR GUIDELINES

We accept the manuscript submissions in any standard (generic) format.

We typeset manuscripts using advanced typesetting tools like Adobe In Design, CorelDraw, TeXnicCenter, and TeXStudio. We usually recommend authors submit their research using any standard format they are comfortable with, and let Global Journals do the rest.

Alternatively, you can download our basic template from <https://globaljournals.org/Template>

Authors should submit their complete paper/article, including text illustrations, graphics, conclusions, artwork, and tables. Authors who are not able to submit manuscript using the form above can email the manuscript department at submit@globaljournals.org or get in touch with chiefeditor@globaljournals.org if they wish to send the abstract before submission.

BEFORE AND DURING SUBMISSION

Authors must ensure the information provided during the submission of a paper is authentic. Please go through the following checklist before submitting:

1. Authors must go through the complete author guideline and understand and *agree to Global Journals' ethics and code of conduct*, along with author responsibilities.
2. Authors must accept the privacy policy, terms, and conditions of Global Journals.
3. Ensure corresponding author's email address and postal address are accurate and reachable.
4. Manuscript to be submitted must include keywords, an abstract, a paper title, co-author(s') names and details (email address, name, phone number, and institution), figures and illustrations in vector format including appropriate captions, tables, including titles and footnotes, a conclusion, results, acknowledgments and references.
5. Authors should submit paper in a ZIP archive if any supplementary files are required along with the paper.
6. Proper permissions must be acquired for the use of any copyrighted material.
7. Manuscript submitted *must not have been submitted or published elsewhere* and all authors must be aware of the submission.

Declaration of Conflicts of Interest

It is required for authors to declare all financial, institutional, and personal relationships with other individuals and organizations that could influence (bias) their research.

POLICY ON PLAGIARISM

Plagiarism is not acceptable in Global Journals submissions at all.

Plagiarized content will not be considered for publication. We reserve the right to inform authors' institutions about plagiarism detected either before or after publication. If plagiarism is identified, we will follow COPE guidelines:

Authors are solely responsible for all the plagiarism that is found. The author must not fabricate, falsify or plagiarize existing research data. The following, if copied, will be considered plagiarism:

- Words (language)
- Ideas
- Findings
- Writings
- Diagrams
- Graphs
- Illustrations
- Lectures



- Printed material
- Graphic representations
- Computer programs
- Electronic material
- Any other original work

AUTHORSHIP POLICIES

Global Journals follows the definition of authorship set up by the Open Association of Research Society, USA. According to its guidelines, authorship criteria must be based on:

1. Substantial contributions to the conception and acquisition of data, analysis, and interpretation of findings.
2. Drafting the paper and revising it critically regarding important academic content.
3. Final approval of the version of the paper to be published.

Changes in Authorship

The corresponding author should mention the name and complete details of all co-authors during submission and in manuscript. We support addition, rearrangement, manipulation, and deletions in authors list till the early view publication of the journal. We expect that corresponding author will notify all co-authors of submission. We follow COPE guidelines for changes in authorship.

Copyright

During submission of the manuscript, the author is confirming an exclusive license agreement with Global Journals which gives Global Journals the authority to reproduce, reuse, and republish authors' research. We also believe in flexible copyright terms where copyright may remain with authors/employers/institutions as well. Contact your editor after acceptance to choose your copyright policy. You may follow this form for copyright transfers.

Appealing Decisions

Unless specified in the notification, the Editorial Board's decision on publication of the paper is final and cannot be appealed before making the major change in the manuscript.

Acknowledgments

Contributors to the research other than authors credited should be mentioned in Acknowledgments. The source of funding for the research can be included. Suppliers of resources may be mentioned along with their addresses.

Declaration of funding sources

Global Journals is in partnership with various universities, laboratories, and other institutions worldwide in the research domain. Authors are requested to disclose their source of funding during every stage of their research, such as making analysis, performing laboratory operations, computing data, and using institutional resources, from writing an article to its submission. This will also help authors to get reimbursements by requesting an open access publication letter from Global Journals and submitting to the respective funding source.

PREPARING YOUR MANUSCRIPT

Authors can submit papers and articles in an acceptable file format: MS Word (doc, docx), LaTeX (.tex, .zip or .rar including all of your files), Adobe PDF (.pdf), rich text format (.rtf), simple text document (.txt), Open Document Text (.odt), and Apple Pages (.pages). Our professional layout editors will format the entire paper according to our official guidelines. This is one of the highlights of publishing with Global Journals—authors should not be concerned about the formatting of their paper. Global Journals accepts articles and manuscripts in every major language, be it Spanish, Chinese, Japanese, Portuguese, Russian, French, German, Dutch, Italian, Greek, or any other national language, but the title, subtitle, and abstract should be in English. This will facilitate indexing and the pre-peer review process.

The following is the official style and template developed for publication of a research paper. Authors are not required to follow this style during the submission of the paper. It is just for reference purposes.



Manuscript Style Instruction (Optional)

- Microsoft Word Document Setting Instructions.
- Font type of all text should be Swis721 Lt BT.
- Page size: 8.27" x 11", left margin: 0.65, right margin: 0.65, bottom margin: 0.75.
- Paper title should be in one column of font size 24.
- Author name in font size of 11 in one column.
- Abstract: font size 9 with the word "Abstract" in bold italics.
- Main text: font size 10 with two justified columns.
- Two columns with equal column width of 3.38 and spacing of 0.2.
- First character must be three lines drop-capped.
- The paragraph before spacing of 1 pt and after of 0 pt.
- Line spacing of 1 pt.
- Large images must be in one column.
- The names of first main headings (Heading 1) must be in Roman font, capital letters, and font size of 10.
- The names of second main headings (Heading 2) must not include numbers and must be in italics with a font size of 10.

Structure and Format of Manuscript

The recommended size of an original research paper is under 15,000 words and review papers under 7,000 words. Research articles should be less than 10,000 words. Research papers are usually longer than review papers. Review papers are reports of significant research (typically less than 7,000 words, including tables, figures, and references)

A research paper must include:

- a) A title which should be relevant to the theme of the paper.
- b) A summary, known as an abstract (less than 150 words), containing the major results and conclusions.
- c) Up to 10 keywords that precisely identify the paper's subject, purpose, and focus.
- d) An introduction, giving fundamental background objectives.
- e) Resources and techniques with sufficient complete experimental details (wherever possible by reference) to permit repetition, sources of information must be given, and numerical methods must be specified by reference.
- f) Results which should be presented concisely by well-designed tables and figures.
- g) Suitable statistical data should also be given.
- h) All data must have been gathered with attention to numerical detail in the planning stage.

Design has been recognized to be essential to experiments for a considerable time, and the editor has decided that any paper that appears not to have adequate numerical treatments of the data will be returned unrefereed.

- i) Discussion should cover implications and consequences and not just recapitulate the results; conclusions should also be summarized.
- j) There should be brief acknowledgments.
- k) There ought to be references in the conventional format. Global Journals recommends APA format.

Authors should carefully consider the preparation of papers to ensure that they communicate effectively. Papers are much more likely to be accepted if they are carefully designed and laid out, contain few or no errors, are summarizing, and follow instructions. They will also be published with much fewer delays than those that require much technical and editorial correction.

The Editorial Board reserves the right to make literary corrections and suggestions to improve brevity.



FORMAT STRUCTURE

It is necessary that authors take care in submitting a manuscript that is written in simple language and adheres to published guidelines.

All manuscripts submitted to Global Journals should include:

Title

The title page must carry an informative title that reflects the content, a running title (less than 45 characters together with spaces), names of the authors and co-authors, and the place(s) where the work was carried out.

Author details

The full postal address of any related author(s) must be specified.

Abstract

The abstract is the foundation of the research paper. It should be clear and concise and must contain the objective of the paper and inferences drawn. It is advised to not include big mathematical equations or complicated jargon.

Many researchers searching for information online will use search engines such as Google, Yahoo or others. By optimizing your paper for search engines, you will amplify the chance of someone finding it. In turn, this will make it more likely to be viewed and cited in further works. Global Journals has compiled these guidelines to facilitate you to maximize the web-friendliness of the most public part of your paper.

Keywords

A major lynchpin of research work for the writing of research papers is the keyword search, which one will employ to find both library and internet resources. Up to eleven keywords or very brief phrases have to be given to help data retrieval, mining, and indexing.

One must be persistent and creative in using keywords. An effective keyword search requires a strategy: planning of a list of possible keywords and phrases to try.

Choice of the main keywords is the first tool of writing a research paper. Research paper writing is an art. Keyword search should be as strategic as possible.

One should start brainstorming lists of potential keywords before even beginning searching. Think about the most important concepts related to research work. Ask, "What words would a source have to include to be truly valuable in a research paper?" Then consider synonyms for the important words.

It may take the discovery of only one important paper to steer in the right keyword direction because, in most databases, the keywords under which a research paper is abstracted are listed with the paper.

Numerical Methods

Numerical methods used should be transparent and, where appropriate, supported by references.

Abbreviations

Authors must list all the abbreviations used in the paper at the end of the paper or in a separate table before using them.

Formulas and equations

Authors are advised to submit any mathematical equation using either MathJax, KaTeX, or LaTeX, or in a very high-quality image.

Tables, Figures, and Figure Legends

Tables: Tables should be cautiously designed, uncrowned, and include only essential data. Each must have an Arabic number, e.g., Table 4, a self-explanatory caption, and be on a separate sheet. Authors must submit tables in an editable format and not as images. References to these tables (if any) must be mentioned accurately.



Figures

Figures are supposed to be submitted as separate files. Always include a citation in the text for each figure using Arabic numbers, e.g., Fig. 4. Artwork must be submitted online in vector electronic form or by emailing it.

PREPARATION OF ELETRONIC FIGURES FOR PUBLICATION

Although low-quality images are sufficient for review purposes, print publication requires high-quality images to prevent the final product being blurred or fuzzy. Submit (possibly by e-mail) EPS (line art) or TIFF (halftone/ photographs) files only. MS PowerPoint and Word Graphics are unsuitable for printed pictures. Avoid using pixel-oriented software. Scans (TIFF only) should have a resolution of at least 350 dpi (halftone) or 700 to 1100 dpi (line drawings). Please give the data for figures in black and white or submit a Color Work Agreement form. EPS files must be saved with fonts embedded (and with a TIFF preview, if possible).

For scanned images, the scanning resolution at final image size ought to be as follows to ensure good reproduction: line art: >650 dpi; halftones (including gel photographs): >350 dpi; figures containing both halftone and line images: >650 dpi.

Color charges: Authors are advised to pay the full cost for the reproduction of their color artwork. Hence, please note that if there is color artwork in your manuscript when it is accepted for publication, we would require you to complete and return a Color Work Agreement form before your paper can be published. Also, you can email your editor to remove the color fee after acceptance of the paper.

TIPS FOR WRITING A GOOD QUALITY MEDICAL RESEARCH PAPER

1. Choosing the topic: In most cases, the topic is selected by the interests of the author, but it can also be suggested by the guides. You can have several topics, and then judge which you are most comfortable with. This may be done by asking several questions of yourself, like "Will I be able to carry out a search in this area? Will I find all necessary resources to accomplish the search? Will I be able to find all information in this field area?" If the answer to this type of question is "yes," then you ought to choose that topic. In most cases, you may have to conduct surveys and visit several places. Also, you might have to do a lot of work to find all the rises and falls of the various data on that subject. Sometimes, detailed information plays a vital role, instead of short information. Evaluators are human: The first thing to remember is that evaluators are also human beings. They are not only meant for rejecting a paper. They are here to evaluate your paper. So present your best aspect.

2. Think like evaluators: If you are in confusion or getting demotivated because your paper may not be accepted by the evaluators, then think, and try to evaluate your paper like an evaluator. Try to understand what an evaluator wants in your research paper, and you will automatically have your answer. Make blueprints of paper: The outline is the plan or framework that will help you to arrange your thoughts. It will make your paper logical. But remember that all points of your outline must be related to the topic you have chosen.

3. Ask your guides: If you are having any difficulty with your research, then do not hesitate to share your difficulty with your guide (if you have one). They will surely help you out and resolve your doubts. If you can't clarify what exactly you require for your work, then ask your supervisor to help you with an alternative. He or she might also provide you with a list of essential readings.

4. Use of computer is recommended: As you are doing research in the field of medical research then this point is quite obvious. Use right software: Always use good quality software packages. If you are not capable of judging good software, then you can lose the quality of your paper unknowingly. There are various programs available to help you which you can get through the internet.

5. Use the internet for help: An excellent start for your paper is using Google. It is a wondrous search engine, where you can have your doubts resolved. You may also read some answers for the frequent question of how to write your research paper or find a model research paper. You can download books from the internet. If you have all the required books, place importance on reading, selecting, and analyzing the specified information. Then sketch out your research paper. Use big pictures: You may use encyclopedias like Wikipedia to get pictures with the best resolution. At Global Journals, you should strictly follow here.



6. Bookmarks are useful: When you read any book or magazine, you generally use bookmarks, right? It is a good habit which helps to not lose your continuity. You should always use bookmarks while searching on the internet also, which will make your search easier.

7. Revise what you wrote: When you write anything, always read it, summarize it, and then finalize it.

8. Make every effort: Make every effort to mention what you are going to write in your paper. That means always have a good start. Try to mention everything in the introduction—what is the need for a particular research paper. Polish your work with good writing skills and always give an evaluator what he wants. Make backups: When you are going to do any important thing like making a research paper, you should always have backup copies of it either on your computer or on paper. This protects you from losing any portion of your important data.

9. Produce good diagrams of your own: Always try to include good charts or diagrams in your paper to improve quality. Using several unnecessary diagrams will degrade the quality of your paper by creating a hodgepodge. So always try to include diagrams which were made by you to improve the readability of your paper. Use of direct quotes: When you do research relevant to literature, history, or current affairs, then use of quotes becomes essential, but if the study is relevant to science, use of quotes is not preferable.

10. Use proper verb tense: Use proper verb tenses in your paper. Use past tense to present those events that have happened. Use present tense to indicate events that are going on. Use future tense to indicate events that will happen in the future. Use of wrong tenses will confuse the evaluator. Avoid sentences that are incomplete.

11. Pick a good study spot: Always try to pick a spot for your research which is quiet. Not every spot is good for studying.

12. Know what you know: Always try to know what you know by making objectives, otherwise you will be confused and unable to achieve your target.

13. Use good grammar: Always use good grammar and words that will have a positive impact on the evaluator; use of good vocabulary does not mean using tough words which the evaluator has to find in a dictionary. Do not fragment sentences. Eliminate one-word sentences. Do not ever use a big word when a smaller one would suffice.

Verbs have to be in agreement with their subjects. In a research paper, do not start sentences with conjunctions or finish them with prepositions. When writing formally, it is advisable to never split an infinitive because someone will (wrongly) complain. Avoid clichés like a disease. Always shun irritating alliteration. Use language which is simple and straightforward. Put together a neat summary.

14. Arrangement of information: Each section of the main body should start with an opening sentence, and there should be a changeover at the end of the section. Give only valid and powerful arguments for your topic. You may also maintain your arguments with records.

15. Never start at the last minute: Always allow enough time for research work. Leaving everything to the last minute will degrade your paper and spoil your work.

16. Multitasking in research is not good: Doing several things at the same time is a bad habit in the case of research activity. Research is an area where everything has a particular time slot. Divide your research work into parts, and do a particular part in a particular time slot.

17. Never copy others' work: Never copy others' work and give it your name because if the evaluator has seen it anywhere, you will be in trouble. Take proper rest and food: No matter how many hours you spend on your research activity, if you are not taking care of your health, then all your efforts will have been in vain. For quality research, take proper rest and food.

18. Go to seminars: Attend seminars if the topic is relevant to your research area. Utilize all your resources.

19. Refresh your mind after intervals: Try to give your mind a rest by listening to soft music or sleeping in intervals. This will also improve your memory. Acquire colleagues: Always try to acquire colleagues. No matter how sharp you are, if you acquire colleagues, they can give you ideas which will be helpful to your research.



20. Think technically: Always think technically. If anything happens, search for its reasons, benefits, and demerits. Think and then print: When you go to print your paper, check that tables are not split, headings are not detached from their descriptions, and page sequence is maintained.

21. Adding unnecessary information: Do not add unnecessary information like "I have used MS Excel to draw graphs." Irrelevant and inappropriate material is superfluous. Foreign terminology and phrases are not apropos. One should never take a broad view. Analogy is like feathers on a snake. Use words properly, regardless of how others use them. Remove quotations. Puns are for kids, not grunt readers. Never oversimplify: When adding material to your research paper, never go for oversimplification; this will definitely irritate the evaluator. Be specific. Never use rhythmic redundancies. Contractions shouldn't be used in a research paper. Comparisons are as terrible as clichés. Give up ampersands, abbreviations, and so on. Remove commas that are not necessary. Parenthetical words should be between brackets or commas. Understatement is always the best way to put forward earth-shaking thoughts. Give a detailed literary review.

22. Report concluded results: Use concluded results. From raw data, filter the results, and then conclude your studies based on measurements and observations taken. An appropriate number of decimal places should be used. Parenthetical remarks are prohibited here. Proofread carefully at the final stage. At the end, give an outline to your arguments. Spot perspectives of further study of the subject. Justify your conclusion at the bottom sufficiently, which will probably include examples.

23. Upon conclusion: Once you have concluded your research, the next most important step is to present your findings. Presentation is extremely important as it is the definite medium through which your research is going to be in print for the rest of the crowd. Care should be taken to categorize your thoughts well and present them in a logical and neat manner. A good quality research paper format is essential because it serves to highlight your research paper and bring to light all necessary aspects of your research.

INFORMAL GUIDELINES OF RESEARCH PAPER WRITING

Key points to remember:

- Submit all work in its final form.
- Write your paper in the form which is presented in the guidelines using the template.
- Please note the criteria peer reviewers will use for grading the final paper.

Final points:

One purpose of organizing a research paper is to let people interpret your efforts selectively. The journal requires the following sections, submitted in the order listed, with each section starting on a new page:

The introduction: This will be compiled from reference matter and reflect the design processes or outline of basis that directed you to make a study. As you carry out the process of study, the method and process section will be constructed like that. The results segment will show related statistics in nearly sequential order and direct reviewers to similar intellectual paths throughout the data that you gathered to carry out your study.

The discussion section:

This will provide understanding of the data and projections as to the implications of the results. The use of good quality references throughout the paper will give the effort trustworthiness by representing an alertness to prior workings.

Writing a research paper is not an easy job, no matter how trouble-free the actual research or concept. Practice, excellent preparation, and controlled record-keeping are the only means to make straightforward progression.

General style:

Specific editorial column necessities for compliance of a manuscript will always take over from directions in these general guidelines.

To make a paper clear: Adhere to recommended page limits.



Mistakes to avoid:

- Insertion of a title at the foot of a page with subsequent text on the next page.
- Separating a table, chart, or figure—confine each to a single page.
- Submitting a manuscript with pages out of sequence.
- In every section of your document, use standard writing style, including articles ("a" and "the").
- Keep paying attention to the topic of the paper.
- Use paragraphs to split each significant point (excluding the abstract).
- Align the primary line of each section.
- Present your points in sound order.
- Use present tense to report well-accepted matters.
- Use past tense to describe specific results.
- Do not use familiar wording; don't address the reviewer directly. Don't use slang or superlatives.
- Avoid use of extra pictures—include only those figures essential to presenting results.

Title page:

Choose a revealing title. It should be short and include the name(s) and address(es) of all authors. It should not have acronyms or abbreviations or exceed two printed lines.

Abstract: This summary should be two hundred words or less. It should clearly and briefly explain the key findings reported in the manuscript and must have precise statistics. It should not have acronyms or abbreviations. It should be logical in itself. Do not cite references at this point.

An abstract is a brief, distinct paragraph summary of finished work or work in development. In a minute or less, a reviewer can be taught the foundation behind the study, common approaches to the problem, relevant results, and significant conclusions or new questions.

Write your summary when your paper is completed because how can you write the summary of anything which is not yet written? Wealth of terminology is very essential in abstract. Use comprehensive sentences, and do not sacrifice readability for brevity; you can maintain it succinctly by phrasing sentences so that they provide more than a lone rationale. The author can at this moment go straight to shortening the outcome. Sum up the study with the subsequent elements in any summary. Try to limit the initial two items to no more than one line each.

Reason for writing the article—theory, overall issue, purpose.

- Fundamental goal.
- To-the-point depiction of the research.
- Consequences, including definite statistics—if the consequences are quantitative in nature, account for this; results of any numerical analysis should be reported. Significant conclusions or questions that emerge from the research.

Approach:

- Single section and succinct.
- An outline of the job done is always written in past tense.
- Concentrate on shortening results—limit background information to a verdict or two.
- Exact spelling, clarity of sentences and phrases, and appropriate reporting of quantities (proper units, important statistics) are just as significant in an abstract as they are anywhere else.

Introduction:

The introduction should "introduce" the manuscript. The reviewer should be presented with sufficient background information to be capable of comprehending and calculating the purpose of your study without having to refer to other works. The basis for the study should be offered. Give the most important references, but avoid making a comprehensive appraisal of the topic. Describe the problem visibly. If the problem is not acknowledged in a logical, reasonable way, the reviewer will give no attention to your results. Speak in common terms about techniques used to explain the problem, if needed, but do not present any particulars about the protocols here.



The following approach can create a valuable beginning:

- Explain the value (significance) of the study.
- Defend the model—why did you employ this particular system or method? What is its compensation? Remark upon its appropriateness from an abstract point of view as well as pointing out sensible reasons for using it.
- Present a justification. State your particular theory(-ies) or aim(s), and describe the logic that led you to choose them.
- Briefly explain the study's tentative purpose and how it meets the declared objectives.

Approach:

Use past tense except for when referring to recognized facts. After all, the manuscript will be submitted after the entire job is done. Sort out your thoughts; manufacture one key point for every section. If you make the four points listed above, you will need at least four paragraphs. Present surrounding information only when it is necessary to support a situation. The reviewer does not desire to read everything you know about a topic. Shape the theory specifically—do not take a broad view.

As always, give awareness to spelling, simplicity, and correctness of sentences and phrases.

Procedures (methods and materials):

This part is supposed to be the easiest to carve if you have good skills. A soundly written procedures segment allows a capable scientist to replicate your results. Present precise information about your supplies. The suppliers and clarity of reagents can be helpful bits of information. Present methods in sequential order, but linked methodologies can be grouped as a segment. Be concise when relating the protocols. Attempt to give the least amount of information that would permit another capable scientist to replicate your outcome, but be cautious that vital information is integrated. The use of subheadings is suggested and ought to be synchronized with the results section.

When a technique is used that has been well-described in another section, mention the specific item describing the way, but draw the basic principle while stating the situation. The purpose is to show all particular resources and broad procedures so that another person may use some or all of the methods in one more study or referee the scientific value of your work. It is not to be a step-by-step report of the whole thing you did, nor is a methods section a set of orders.

Materials:

Materials may be reported in part of a section or else they may be recognized along with your measures.

Methods:

- Report the method and not the particulars of each process that engaged the same methodology.
- Describe the method entirely.
- To be succinct, present methods under headings dedicated to specific dealings or groups of measures.
- Simplify—detail how procedures were completed, not how they were performed on a particular day.
- If well-known procedures were used, account for the procedure by name, possibly with a reference, and that's all.

Approach:

It is embarrassing to use vigorous voice when documenting methods without using first person, which would focus the reviewer's interest on the researcher rather than the job. As a result, when writing up the methods, most authors use third person passive voice.

Use standard style in this and every other part of the paper—avoid familiar lists, and use full sentences.

What to keep away from:

- Resources and methods are not a set of information.
- Skip all descriptive information and surroundings—save it for the argument.
- Leave out information that is immaterial to a third party.



Results:

The principle of a results segment is to present and demonstrate your conclusion. Create this part as entirely objective details of the outcome, and save all understanding for the discussion.

The page length of this segment is set by the sum and types of data to be reported. Use statistics and tables, if suitable, to present consequences most efficiently.

You must clearly differentiate material which would usually be incorporated in a study editorial from any unprocessed data or additional appendix matter that would not be available. In fact, such matters should not be submitted at all except if requested by the instructor.

Content:

- Sum up your conclusions in text and demonstrate them, if suitable, with figures and tables.
- In the manuscript, explain each of your consequences, and point the reader to remarks that are most appropriate.
- Present a background, such as by describing the question that was addressed by creation of an exacting study.
- Explain results of control experiments and give remarks that are not accessible in a prescribed figure or table, if appropriate.
- Examine your data, then prepare the analyzed (transformed) data in the form of a figure (graph), table, or manuscript.

What to stay away from:

- Do not discuss or infer your outcome, report surrounding information, or try to explain anything.
- Do not include raw data or intermediate calculations in a research manuscript.
- Do not present similar data more than once.
- A manuscript should complement any figures or tables, not duplicate information.
- Never confuse figures with tables—there is a difference.

Approach:

As always, use past tense when you submit your results, and put the whole thing in a reasonable order.

Put figures and tables, appropriately numbered, in order at the end of the report.

If you desire, you may place your figures and tables properly within the text of your results section.

Figures and tables:

If you put figures and tables at the end of some details, make certain that they are visibly distinguished from any attached appendix materials, such as raw facts. Whatever the position, each table must be titled, numbered one after the other, and include a heading. All figures and tables must be divided from the text.

Discussion:

The discussion is expected to be the trickiest segment to write. A lot of papers submitted to the journal are discarded based on problems with the discussion. There is no rule for how long an argument should be.

Position your understanding of the outcome visibly to lead the reviewer through your conclusions, and then finish the paper with a summing up of the implications of the study. The purpose here is to offer an understanding of your results and support all of your conclusions, using facts from your research and generally accepted information, if suitable. The implication of results should be fully described.

Infer your data in the conversation in suitable depth. This means that when you clarify an observable fact, you must explain mechanisms that may account for the observation. If your results vary from your prospect, make clear why that may have happened. If your results agree, then explain the theory that the proof supported. It is never suitable to just state that the data approved the prospect, and let it drop at that. Make a decision as to whether each premise is supported or discarded or if you cannot make a conclusion with assurance. Do not just dismiss a study or part of a study as "uncertain."



Research papers are not acknowledged if the work is imperfect. Draw what conclusions you can based upon the results that you have, and take care of the study as a finished work.

- You may propose future guidelines, such as how an experiment might be personalized to accomplish a new idea.
- Give details of all of your remarks as much as possible, focusing on mechanisms.
- Make a decision as to whether the tentative design sufficiently addressed the theory and whether or not it was correctly restricted. Try to present substitute explanations if they are sensible alternatives.
- One piece of research will not counter an overall question, so maintain the large picture in mind. Where do you go next? The best studies unlock new avenues of study. What questions remain?
- Recommendations for detailed papers will offer supplementary suggestions.

Approach:

When you refer to information, differentiate data generated by your own studies from other available information. Present work done by specific persons (including you) in past tense.

Describe generally acknowledged facts and main beliefs in present tense.

THE ADMINISTRATION RULES

Administration Rules to Be Strictly Followed before Submitting Your Research Paper to Global Journals Inc.

Please read the following rules and regulations carefully before submitting your research paper to Global Journals Inc. to avoid rejection.

Segment draft and final research paper: You have to strictly follow the template of a research paper, failing which your paper may get rejected. You are expected to write each part of the paper wholly on your own. The peer reviewers need to identify your own perspective of the concepts in your own terms. Please do not extract straight from any other source, and do not rephrase someone else's analysis. Do not allow anyone else to proofread your manuscript.

Written material: You may discuss this with your guides and key sources. Do not copy anyone else's paper, even if this is only imitation, otherwise it will be rejected on the grounds of plagiarism, which is illegal. Various methods to avoid plagiarism are strictly applied by us to every paper, and, if found guilty, you may be blacklisted, which could affect your career adversely. To guard yourself and others from possible illegal use, please do not permit anyone to use or even read your paper and file.



CRITERION FOR GRADING A RESEARCH PAPER (COMPILATION)
BY GLOBAL JOURNALS

Please note that following table is only a Grading of "Paper Compilation" and not on "Performed/Stated Research" whose grading solely depends on Individual Assigned Peer Reviewer and Editorial Board Member. These can be available only on request and after decision of Paper. This report will be the property of Global Journals.

Topics	Grades		
	A-B	C-D	E-F
<i>Abstract</i>	Clear and concise with appropriate content, Correct format. 200 words or below	Unclear summary and no specific data, Incorrect form Above 200 words	No specific data with ambiguous information Above 250 words
<i>Introduction</i>	Containing all background details with clear goal and appropriate details, flow specification, no grammar and spelling mistake, well organized sentence and paragraph, reference cited	Unclear and confusing data, appropriate format, grammar and spelling errors with unorganized matter	Out of place depth and content, hazy format
<i>Methods and Procedures</i>	Clear and to the point with well arranged paragraph, precision and accuracy of facts and figures, well organized subheads	Difficult to comprehend with embarrassed text, too much explanation but completed	Incorrect and unorganized structure with hazy meaning
<i>Result</i>	Well organized, Clear and specific, Correct units with precision, correct data, well structuring of paragraph, no grammar and spelling mistake	Complete and embarrassed text, difficult to comprehend	Irregular format with wrong facts and figures
<i>Discussion</i>	Well organized, meaningful specification, sound conclusion, logical and concise explanation, highly structured paragraph reference cited	Wordy, unclear conclusion, spurious	Conclusion is not cited, unorganized, difficult to comprehend
<i>References</i>	Complete and correct format, well organized	Beside the point, Incomplete	Wrong format and structuring



INDEX

A

Augmented · 8, 4

B

Ballistics · 1, 2, 6, 7

C

Catheterization · 11, 12, 13, 14
Cumbersome · 3

E

Excoriated · 4

R

Randomized · 3, 7, 8
Retroperitoneal · 12
Rocuronium · 12

T

Traumatology · 6

V

Vasoconstrictors · 12



save our planet



Global Journal of Medical Research

Visit us on the Web at www.GlobalJournals.org | www.MedicalResearchJournal.org
or email us at helpdesk@globaljournals.org

ISSN 9755896

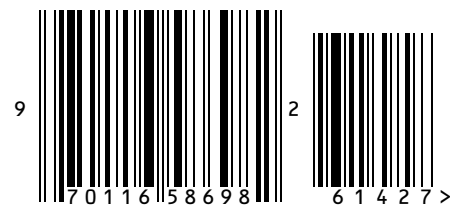

© Global Journals