



GLOBAL JOURNAL OF RESEARCHES IN ENGINEERING  
ELECTRICAL AND ELECTRONICS ENGINEERING  
Volume 12 Issue 2 Version 1.0 February 2012  
Type: Double Blind Peer Reviewed International Research Journal  
Publisher: Global Journals Inc. (USA)  
Online ISSN: 2249-4596 & Print ISSN: 0975-5861

## Design and Implementation of Wireless Digital Energy Meter using Microcontroller

By Md. Ashiquzzaman, Nadia Afroze, Taufiq Md. Abdullah

*Stamford University Bangladesh, Dhaka*

**Abstract** - This paper presents a micro-controller based wireless digital energy meter to facilitate energy consumption measurement and its corresponding billing scheme. Details of design for the construction of energy meter using (Current transformer, Potential transformer, microcontroller, Atmega 16, LCD, Transmitter, Receiver, and a load). Electricity has become one of the basic requirements of human civilization, being widely used for domestic, industrial and agricultural purposes. At present, the need and demand for electricity requires no special mention. In spite of very well developed sources for electricity, both traditional and alternate versions, there are a lot of problems with distribution, metering and billing of electrical energy and its consumption measurement. The problem worsens further in collecting the meter readings and generating the bill. In this paper, a method of using a wireless digital system for automated transmission of data was utilized to make easy energy consumption measurement and its consequent billing system. If we use this energy meter it will be beneficial for the power energy system. It is very cost effective and effortless to operate.

**Keywords** : *Current transformer, Potential transformer, microcontroller (Atmega 16), LCD, Transmitter, Receiver.*

**GJRE-F Classification:** *FOR Code: 090604*



*Strictly as per the compliance and regulations of:*



© 2012 Md. Ashiquzzaman, Nadia Afroze, Taufiq Md. Abdullah. This is a research/review paper, distributed under the terms of the Creative Commons Attribution-Noncommercial 3.0 Unported License (<http://creativecommons.org/licenses/by-nc/3.0/>), permitting all non commercial use, distribution, and reproduction in any medium, provided the original work is properly cited.

# Design and Implementation of Wireless Digital Energy Meter using Microcontroller

Md. Ashiquzzaman<sup>α</sup>, Nadia Afroze<sup>σ</sup>, Taufiq Md. Abdullah<sup>α</sup>

**Abstract** - This paper presents a micro-controller based wireless digital energy meter to facilitate energy consumption measurement and its corresponding billing scheme. Details of design for the construction of energy meter using (Current transformer, Potential transformer, microcontroller, Atmega 16, LCD, Transmitter, Receiver, and a load). Electricity has become one of the basic requirements of human civilization, being widely used for domestic, industrial and agricultural purposes. At present, the need and demand for electricity requires no special mention. In spite of very well developed sources for electricity, both traditional and alternate versions, there are a lot of problems with distribution, metering and billing of electrical energy and its consumption measurement. The problem worsens further in collecting the meter readings and generating the bill. In this paper, a method of using a wireless digital system for automated transmission of data was utilized to make easy energy consumption measurement and its consequent billing system. If we use this energy meter it will be beneficial for the power energy system. It is very cost effective and effortless to operate.

**Keywords** : Current transformer, Potential transformer, microcontroller (Atmega 16), LCD, Transmitter, Receiver.

## I. INTRODUCTION

New and advanced technologies are being discovered and implemented every day. Everyday life serves as a testament to this amazing reality. This science depends on thoughts, logic and dedication. Our surroundings buzz with the advent of new technology. In this thesis, a wireless digital energy meter was made that had the capability to measure power consumption. This project was divided into the following parts:

- A burner, via which programs can be burned (i.e. incorporated into) into the working microcontroller (Atmega 16 in this case) was prepared.
- The energy consumption was calculated in Wh (watt-hour) and shown at the subscriber end.
- The Wh value was transmitted, via a wireless medium and the power system was monitored on a computer using custom software.

A basic high level programming language ("C" in this case) was used to write the codes for the

operation of the energy meter. The microcontroller was programmed by using the software Code Vision AVR. This project has been field tested several times and was proved to be highly accurate and effective.

This thesis describes one method used to accomplish the above task. It is able to show voltage, current, power factor, power consumption and maximum demand. This thesis also contains the details of the method of UART (universal synchronous receiver/transmitter) communication to transmit the data to the PC. After several attempts, a unique design of this digital energy meter was achieved.

## II. OBJECTIVES

The objective was to create something that would be helpful to modern civilization and take man a step closer in his endeavor to ease the tasks of routine life. Thus, the idea of making a wireless digital energy meter was born. The main objective of this thesis divides into the following different steps:

- Measurement of current using current transformer.
- Measurement of voltage using potential transformer.
- Measurement of power factor.
- Taking the current, voltage and power factor value as ADC input of the microcontroller (Atmega16) and then calculating Wh.

Efforts were also made to solve the random problems which might occur in real life situations. However, the functional capacity could not be tested in a commercial establishment because of the lack of time. Further work on the improvement of this project, can take this to a level where it can be industrially viable.

This project "Wireless Digital Energy Meter" consists of the complicated, intricate and elaborate use of electrical and electronic components and coding, with the aim of digitizing and automating the process of electrical energy measurement as far as possible. The project was implemented by using components and software that were available in the market. Analyzing the various methods of implementation of the energy meter, the method described in this thesis was judged to be the best.

**Author<sup>α</sup>** : Department of Electrical and Electronic Engineering, Stamford University Bangladesh, Dhaka-1217, Bangladesh. E-mail : sharad31@yahoo.com, t.m.abdullah@gmail.com.

**Author<sup>σ</sup>** : Department of Electrical and Electronic Engineering, American International University-Bangladesh, Dhaka-1213, Bangladesh. E-mail : nadiaafroze@yahoo.com.

### III. OPERATION AND RESULTS

The basic operation of the energy meter is to measure the power consumed in Wh (watt-hour) for a given load. Using the network of all interconnections the current and voltage of the line are obtained from their appropriate transformers.

#### a) Microcontroller Coding

Microcontroller coding has been done in Code Vision AVR software. At first using the ADC subsystem of the microcontroller, analog data inputs of voltage and current have been taken. Digital value is generated for both the sinusoidal waves of voltage and current. Peak value is monitored only when the wave is at rising period. After that voltage peak is determined and actual voltage value is calculated. Similar procedure is applied for determining current value. After that power factor is calculated. Timer subsystem is used for the calculation of power factor.

After getting all necessary values, the energy consumption is calculated and updated according to the time. After the calculations, energy consumption and maximum demand value is transmitted using wireless transmitter. The procedure is described in Fig. 1. The readings obtained are stepped down as the microcontroller (Atmega 16) has a working voltage of 5V, which, if exceeded will damage it. The current transformer is connected in series and the potential transformer in parallel with the line. From the current transformer, two outputs are taken as inputs of the microcontroller at the ports ADC (1) & ADC (2). They are as follows:

**ADC (1):** taking current value as input for calculation of power factor

**ADC (2):** taking current value as input for calculating current rating.

Similarly, from the potential transformer, two outputs are taken as inputs of the microcontroller at the ports ADC (0) & ADC (3):

**ADC (0):** output of voltage power factor.

**ADC (3):** output of voltage peak.

Another set of outputs from the potential transformer is also taken as input of a full bridge rectifier to convert 12V AC voltage to a 12V DC voltage. The rectified voltage is then passed through a network of some capacitors, switch, voltage regulator to obtain a voltage of 5V, which is sufficient as the working voltage for the microcontroller and LCD. To convert the 12V DC voltage to a fixed 5V DC voltage, a voltage regulator with a switch was used.

A capacitor bank was used to minimize noise in the output voltage. The block diagrams in Fig. 2 and Fig. 3 show the connections (in a simplified manner) for the operation of the meter, at the transmitter and receiver end respectively.

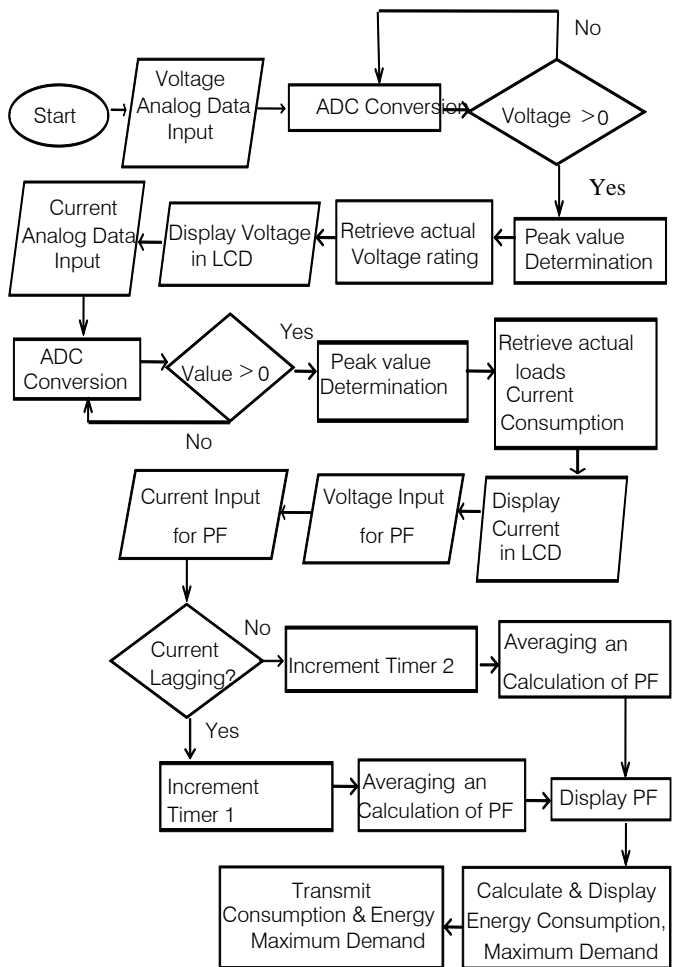

Fig. 1 : Microcontroller programming flowchart.

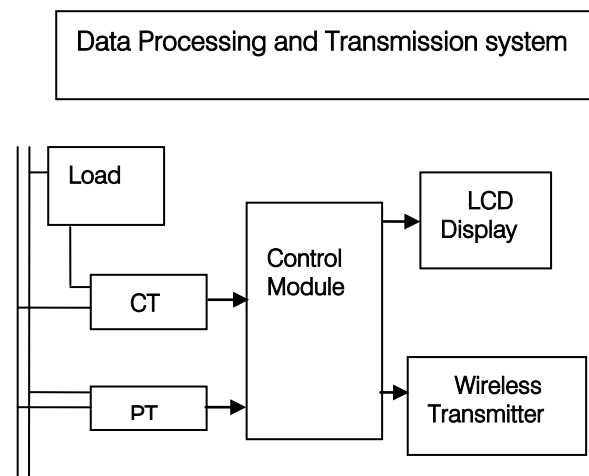

Fig. 2 : Block diagram of the energy meter system showing the subscriber's end.

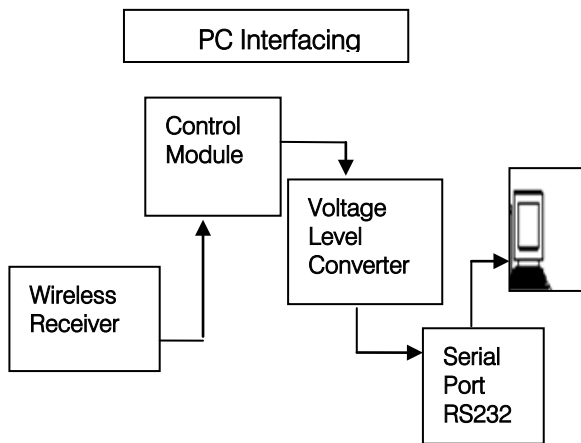

Fig. 3 : Computer interfacing at the receiver end.

b) *Determining voltage and current*

The ADC subsystem converts the analog signal input of voltage and current to a discrete value [1]. While monitoring the ADC input, for the maximum (peak) value the corresponding actual voltage and current value is calculated by multiplying the discrete value with 0.579 and 0.000925 respectively. To determine the peak value of voltage, output from the PT is connected to a voltage divider circuit which consists of a fixed  $10K\Omega$  resistor and a variable resistor. The voltage across the variable resistor is then provided to the ADC (3) pin to calculate the peak value of the voltage. The same strategy is applied in case of determining the peak of the current. For peak value of current, the ADC (2) pin was used.

c) *Determining power factor (PF)*

For determining the power factor, the ADC subsystem and timer subsystem was used. When the voltage crosses zero from positive to negative, the timer is started and its incremented with a frequency of 31.25KHz (or 32 us). When current crosses zero from positive to negative the timer is stopped. This digital value of the timer is then multiplied with two constant terms to get the actual degree deviation.

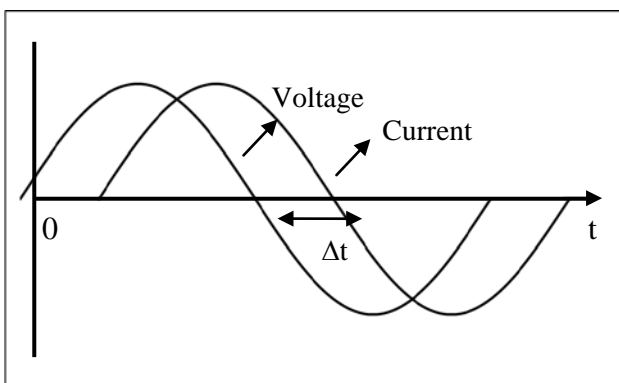

Fig. 4 : Time difference between zero crossing & negative going voltage and current waves.

The desired power is calculated from:  $P = VI\cos\theta$  [2]. The value of voltage, current and power factor is displayed in the LCD with a 2 second interval. So about after each 9 seconds we are calculating the power. This time is converted to hour and multiplied with the power value to get the energy consumption.

$$E = P * \text{Time} = \text{Watt-hour} [3]$$

The data is transmitted with the transmitter of the wireless transmitter-receiver pair to the PC Interface unit. On that unit, the data is received with the help of the wireless receiver. At the supplier end, the receiver is interfaced with a computer to display the following values:

1. Maximum demand
2. Total energy consumption

d) *Experimental values*

The values measured for different types of loads during test runs are as follows:

Load	Voltage	Current	Power factor
100W bulb (resistive load)	214.16V	0.42A	1.0
40W tube light (inductive load)	214.23V	0.38A	0.60
100Wbulb+40W tube light	214.81V	0.64A	0.91

Table. 1 : Experimental values for different loads.

The above readings are consistent with known values for these loads.

#### IV. COMPUTERIZED MONITORING SYSTEM

As part of the project, the data received through the serial port needs to be displayed in a computer monitor and a mechanism is required to store the values in a database. For making the monitoring system, Visual Basic 6.0 was used as the IDE (Integrated Design Environment).

a) *Visual Basic IDE*

Visual Studio 6.0 consists of all necessary components which are called control required for software creation. Some necessary control items that are used in this project's graphical user interface are label, textbox, and data, MSFlexGrid, VScrollbar, Timer and Command Button.

b) *Coding Strategy*

Energy consumption and maximum demand values are transmitted as a data packet. Now in the receiver part, from the data packet the necessary values are separated using text manipulation of strings.

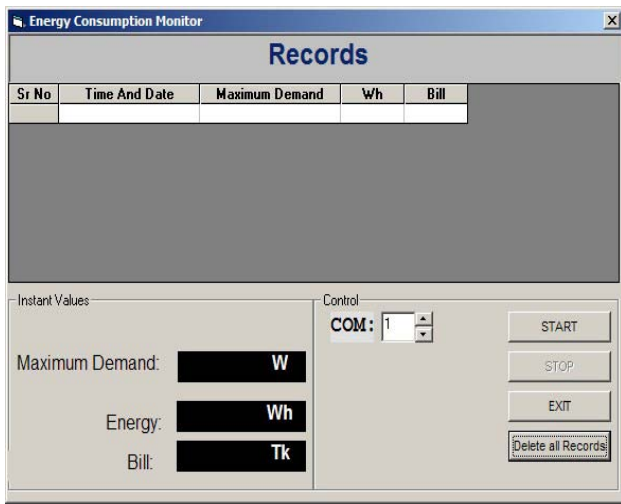

Fig. 5 : Computerized monitoring system (model) screenshot.

used in this regard had to be of a general nature, which would not require highly specialized personnel for maintenance and thus entail further cost of implementation. Therefore, the programming language chosen was "C". With these factors in mind, a prototype device and system were developed successfully, incorporating the features discussed. It was a digital meter that was able to show the current, voltage, power factor, and maximum power demand and power consumption of the load. Further improvements and modifications can be implemented on the project to achieve more varying types of functions and usability.

#### a) Applications of the energy meter

This meter developed in the project serves as a prototype, and can measure consumption of small loads (up to 150W) successfully. Along with the consumption, the power factor and maximum demand are also displayed accurately. Based on this observation, and the fact that consumption of larger loads or a combination of loads can also be measured by making a few minor adjustments, this energy meter can be put to use in households as well as in industrial purposes.

For household applications, the primary concern is the kilowatt-hour rating and the corresponding billing associated with it. The power factor does not hold too great a significance, as the loads in households are mainly either inductive or resistive. So, there will be no major power factor change in these applications. Since the cost of installation and setup of this meter is inexpensive, it will act as an economically feasible choice for this application.

For industrial applications, the power factor is also a primary concern. Various electrical machines, mainly induction motors, synchronous motors, alternators etc. are utilized in industrial fields. Aside from real power, there is also the reactive power that these machines produce, which alters the power factor continuously. This is due to the varying inductive and capacitive loads that are present. So, unless a method of accurate power factor measurement and billing is devised, the values will be error prone. The energy meter developed in this project provides a cheap and reliable alternative.

#### b) Suggestions for future work

As stated earlier, the aim of the project was to devise an efficient digital energy measurement and billing system, which was cost effective and flexible in the sense that further applications were made possible by a relatively few minor adjustments. Therefore, the energy meter developed here is a prototype and some of the modifications that can be implemented are listed below:

1. Modification for measuring energy consumption of larger loads.
2. Inclusion of a group of users.

Then after the separation values are displayed as well as stored in the database along with the date and time information. As this energy meter served as a prototype for employing the concepts shown in the project, there is significant room for modifications and improvement. If the need arises, that additional readings are required than the ones shown, then the only adjustment required is an addition of new functions via the software. For example, the voltage and current could also be displayed just by coding the relevant details in the software.

A computerized monitoring system helps to easily identify the detailed information of the electricity consumption. This chapter aims to provide adequate information about the software and its backend programming concept.

## V. EXPERIMENTAL ANALYSIS

The aim of the project was to achieve an effective digital wireless system of measurement and billing of the electrical energy consumption of loads. This system would have the flexibility and capability to be modified and manipulated to suit varying environments of electrical load combinations, just by a few minor adjustments. However, the adjustments made as deemed necessary, would have to be cost effective and simple, as such reasons of economic feasibility and complexity may arise and eventually lead to a rejection of the implementation of the project. Another point of consideration in the aim of digitizing the measurements was to simplify the codifying procedures of the microcontrollers and digital display devices to be used. By taking this consideration into account, major changes in the methods and techniques of measurement of the voltages and currents, calculation of the cost of consumption, billing etc. can be made just by alteration of the codes. The programming language

3. Wi-Fi (also known as IEEE802.11 standard).
4. ZigBee.
5. Wi-Max (Worldwide Interoperability for Microwave Access).
6. Incorporating additional functions in the monitoring (or supplier) end.

## VI. CONCLUSION

Modern civilization would be brought to its knees, if a crisis of electricity scarcity ever looms. The cusp of society would collapse. Therefore, the undeniable need for uninterrupted electricity is the prelude to development of any nation in the world today. Day by day, the electricity consumer group is expanding as more people are getting access to electricity. In lieu to this rising demand, there also arises the urgent need for a highly efficient monitoring system that can take into account the varying consumptions of the consumer populace. This project has thus provided a simple, accurate and useful solution in the form of the wireless digital energy meter. Although a prototype, it demonstrated the ease of measurement utilizing software, and thereby eliminating human errors. The robustness and simplicity of programming additional features is a great advantage of this meter. It also is an economical choice forward, as the cost of implementation is less than other similar types of wireless energy meters.

This project, therefore, comes one step closer to the ultimate dream of having a fully automated energy consumption monitoring system, in which a computer can provide all necessary information and incorporate additional features as deemed necessary by itself.

## REFERENCES RÉFÉRENCES REFERENCIAS

1. [http://en.wikipedia.org/wiki/Analog-to-digital\\_converter](http://en.wikipedia.org/wiki/Analog-to-digital_converter).
2. [www.labsanywhere.net/circuit/lectures/lect12/lectur12.php](http://www.labsanywhere.net/circuit/lectures/lect12/lectur12.php).
3. [searchciomidmarket.techtarget.com/definition/watt-hour](http://searchciomidmarket.techtarget.com/definition/watt-hour).



This page is intentionally left blank

