



GLOBAL JOURNAL OF RESEARCHES IN ENGINEERING
ELECTRICAL AND ELECTRONICS ENGINEERING
Volume 12 Issue 6 Version 1.0 May 2012
Type: Double Blind Peer Reviewed International Research Journal
Publisher: Global Journals Inc. (USA)
Online ISSN: 2249-4596 & Print ISSN: 0975-5861

Temperature Control of a Hot Plate Using Microcontroller-Based PWM Technique

By Tabinder Akter, Md. Fazlul Huq , Farzana Alam, Md. Afzalur Rab
& Dr.Md.Habibur Rahman

University of Dhaka

Abstract - The temperature of a hotplate used for prebaking, post baking, dehydration baking etc. changes with time. But, in baking purpose the temperature should remain constant. This work concerned with the designing a new and cost-effective microcontroller based PWM temperature controller to control the temperature of a hot plate. PWM controller has been selected because it has faster and accurate response than the conventional on-off controller. Here, the microcontroller senses the zero crossing of the line voltage and generates a pulse for every half-cycle. The width of the pulse is adjusted to change the firing angle of a TRIAC. The TRIAC is interfaced with the microcontroller circuit using an opto-coupler. The temperature of the hot plate can be increased or decreased using two push-button switches. The preset temperature will be saved in EPROM of microcontroller and displayed on an LCD display. The temperature of the hot plate is sensed by a thermocouple and feedback to the microcontroller. The microcontroller keeps the temperature constant by changing the firing angle of the TRIAC. The system has been constructed and tested successfully.

Keywords : Microcontroller, PWM controller, TRIAC, EPROM, Zero-crossing, Temperature Control.

GJRE-F Classification : FOR Code: 090601,090699



TEMPERATURE CONTROL OF A HOT PLATE USING MICROCONTROLLER-BASED PWM TECHNIQUE

Strictly as per the compliance and regulations of:



RESEARCH | DIVERSITY | ETHICS

© 2012 Tabinder Akter, Md. Fazlul Huq, Farzana Alam, Md. Afzalur Rab & Dr.Md.Habibur Rahman. This is a research/review paper, distributed under the terms of the Creative Commons Attribution-Noncommercial 3.0 Unported License (<http://creativecommons.org/licenses/by-nc/3.0/>), permitting all non commercial use, distribution, and reproduction in any medium, provided the original work is properly cited.

Temperature Control of a Hot Plate Using Microcontroller-Based PWM Technique

Tabinder Akter ^α, Md. Fazlul Huq ^σ, Farzana Alam ^ρ, Md. Afzalur Rab ^ω & Dr.Md.Habibur Rahman^{*}

Abstract - The temperature of a hotplate used for prebaking, post baking, dehydration baking etc. changes with time. But, in baking purpose the temperature should remain constant. This work concerned with the designing a new and cost-effective microcontroller based PWM temperature controller to control the temperature of a hot plate. PWM controller has been selected because it has faster and accurate response than the conventional on-off controller. Here, the microcontroller senses the zero crossing of the line voltage and generates a pulse for every half-cycle. The width of the pulse is adjusted to change the firing angle of a TRIAC. The TRIAC is interfaced with the microcontroller circuit using an opto-coupler. The temperature of the hot plate can be increased or decreased using two push-button switches. The preset temperature will be saved in EPROM of microcontroller and displayed on an LCD display. The temperature of the hot plate is sensed by a thermocouple and fedback to the microcontroller. The microcontroller keeps the temperature constant by changing the firing angle of the TRIAC. The system has been constructed and tested successfully.

General Terms : Hotplate, Opto-coupler, Step-down transformer, Comparator, and Peripheral interface controller (PIC).

Keywords : Microcontroller, PWM controller, TRIAC, EPROM, Zero-crossing, Temperature Control.

I. INTRODUCTION

Photolithography is very important in fabrication process [1]. During this process it is necessary to bake substances at different constant temperatures [2-4]. For baking purpose a hotplate is needed, whose temperature is not normally fixed [5]. Many manufacturers all over the world are supplying electronic equipment to control temperature of a hotplate but those equipments are very costly [6]. This work is intended to design low cost equipment with locally available materials.

The temperature of hotplate increases linearly and can't fix any temperature for a certain period of time. It is needed to fix the temperature of hotplate for a certain period of time. The work is intended to pre-bake or post-bake or hard-bake the Photo-resists spun onto the semiconductor wafers [1].

For a particular application of pre-baking the Positive Photo-resist spun onto 400-450 micron thick Silicon wafer of about 1 cm x 2 cm. A temperature of 100°C is needed to be fixed for 10 minutes or 30 minutes [7-9].

Author α : Dept. of Applied Physics University of Dhaka Dhaka-1000, Bangladesh. E-mail : tabinderkumu@yahoo.com

The research conducted here is a combined hardware and software design process with an objective to develop a versatile control system. The work is divided in two sections: hardware section and software section.

II. BLOCK DIAGRAM OF THE SYSTEM

The block diagram of the system is shown in figure 1. It consists of control unit, feedback unit, temperature heater, power control unit, PWM control, 220V line voltage, zero crossing detector.

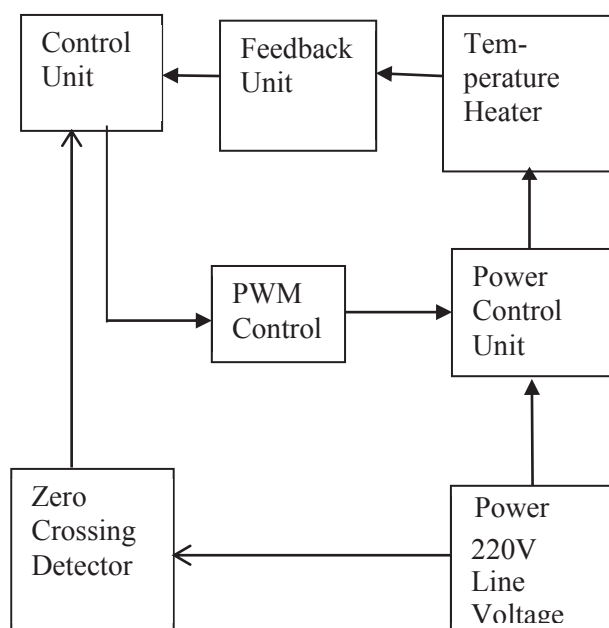

Figure 1 : Overview of the designed system.

III. DESIGN & DEVELOPMENT OF THE SYSTEM

Hardware development

This section is divided into four subsections: Feedback unit, Power control unit, control selection and PWM controller section.

a) Feedback Unit

The temperature of hotplate is displayed by an LCD which is connected with a 16F877 microcontroller. Hotplate converts temperature into voltage by a thermocouple. A high gained amplifier is used in the ADC input of the microcontroller. The hotplate temperature is fedback by this amplifier section. This section is important because the temperature sensed by a thermocouple is so small and need to amplify. The

temperature is then compared with the preset value for adjusting with the target value.

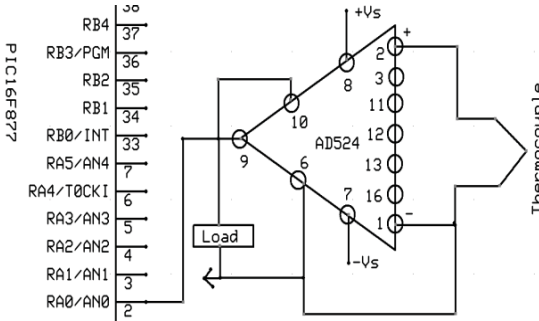

Figure 2 : Feedback Unit

b) Control unit

This unit works as the heart of the complete system. This unit is constructed using a microcontroller. It generates PWM signals and changes the width to keep the temperature constant [10]. It also synchronizes the PWM signal with the line voltage. To keep the plate temperature constant, it takes feedback from the plate. The plate temperature is sensed by a thermocouple and amplified by an instrumentation amplifier and applied to the microcontroller. The input voltage is then converted to digital signal by the ADC of the PIC16F877A and compared to the data stored in the EEPROM of the IC [11-13]. The LCD is connected with one of the output port of the microcontroller [14]. Switches have been connected with two input pins of an input port. The port was so programmed that it scans to check if the switch was pressed or not. By pressing the switches the set value of the temperature can be increased or decreased.

PIC16F877A have total 28 pins as shown in figure 3. Pin-1 (\overline{MCLR}/VPP) of the IC is connected with VCC through a resistance [14]. This pin is the master reset pin. When the pin is connected with ground, the current program is reset and starts executing from the beginning of the program when again connected with V_{cc} .

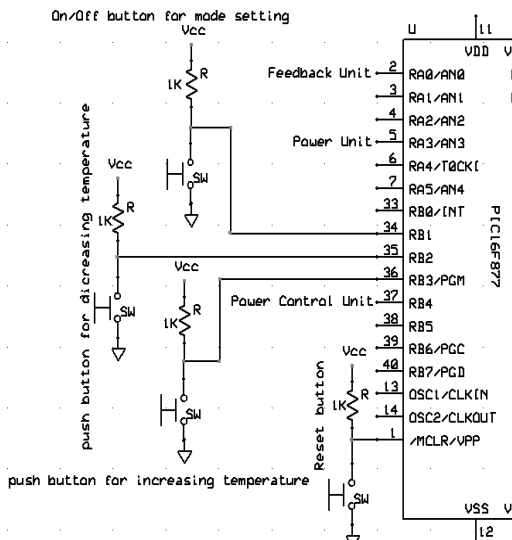

Figure 3 : Control Unit.

c) Power Control Unit

To isolate the microcontroller based control system from the high power side an opto-coupler has been used to fire the TRIAC [14]. The main type of opto-coupler found in the local market is the type having an output DIAC or bilateral switch, and intended for use in driving a TRIAC or SCR. Examples of these are the MOC3020 and MOC3021. Here the output side of the opto-coupler is designed to be connected directly into the triggering circuit of the TRIAC.

As expected, the output of the DIAC is connected into the TRIAC gate triggering circuit in much the same way as a discrete DIAC. We need a filter/delay circuit before the DIAC (R1-2 and C1) and the usual snubber circuit across the TRIAC (Rs,Cs) to ensure correct triggering with inductive loads. Normally also need at least an RFI suppressor choke LRF1 as well, plus a suitable capacitor across the load [14].

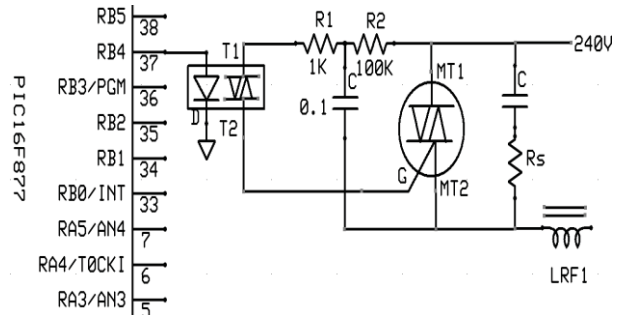

Figure 4 : Power Control Unit.

d) PWM Controller

In this system, the line voltage has been lowered down by a step-down transformer and the sine-wave is directly given into a comparator of the microcontroller [15] which acts as a zero crossing detector. The comparator compares this signal with zero reference voltage. Whenever a transition is produced at the output of the comparator, the microcontroller begins a pulse whose width depends on the preset value of the temperature.

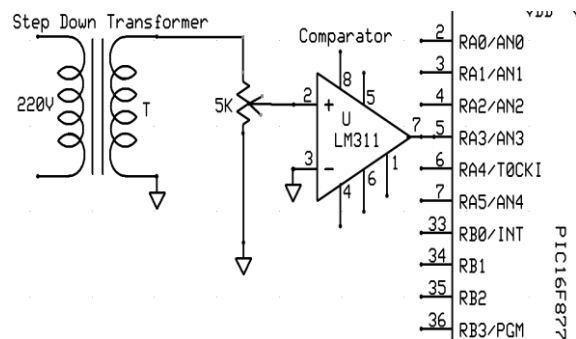

Figure 5 : Power Unit.

IV. SOFTWARE DEVELOPMENT

The system is fully controlled by a program. The program has been written using FlowCode software. First, we set a temperature as shown in figure 6.

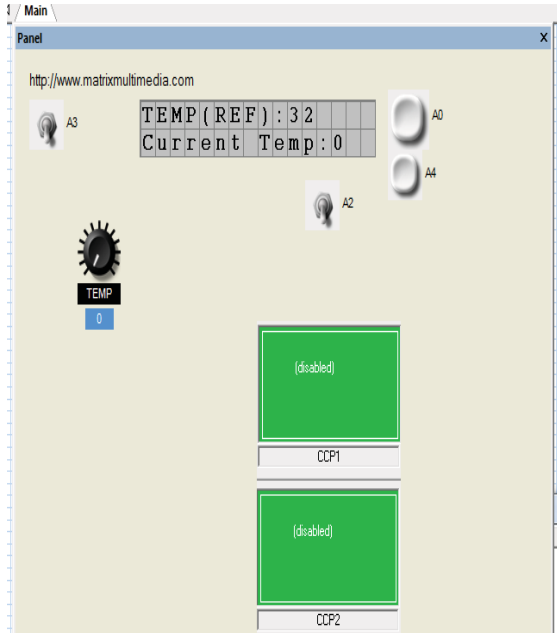

Figure 6 : Output of the program

Then we must on the switch A3, A2 and also on the temperature button. It will start to work and set the hotplate's temperature. The output is shown in figure 7.

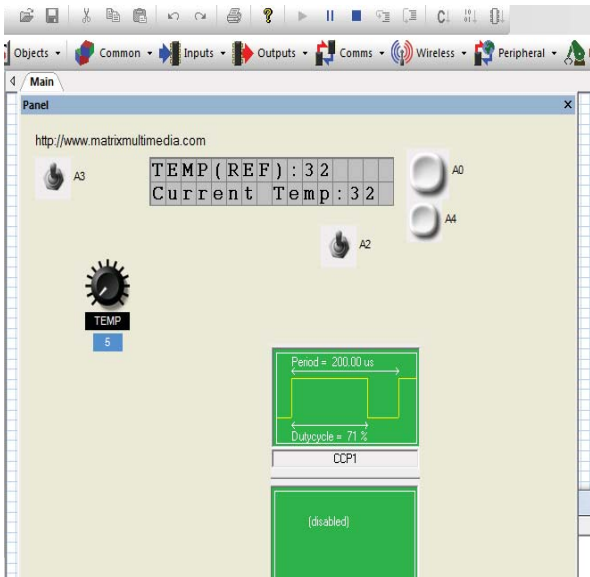

Figure 7 : Output of the program (continued)

Here, hotplate temperature is controlled using duty cycle. For greater temperature it increases its duty cycle and for lower temperature it decreases its duty cycle for controlling the temperature.

V. RESULTS & DISCUSSION

a) Temperature Reading of a Hotplate

Our system is now ready to fix the temperature. We set our circuitry with the hotplate and control its temperature [3]. Our designed program is nice and work properly. The observed data of a hotplate for a set value of temperature is given below:

Data Table 1 : (For Preset Temp. 70°C)

TIME	TEMPERATURE
0.2	15
2	40
4	60
5	68.2
6	70
10	70

The graph associated with the table is shown below:

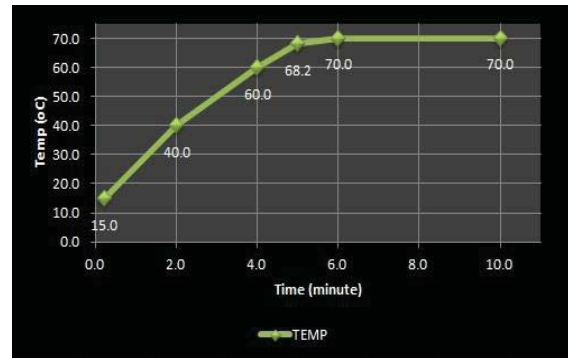

Figure 8 : Graph for Preset temperature 70°C (Table 1).

It is evident that the temperature was increased from 15°C to 70°C for 5 minutes and after 5 minutes the temperature of the hotplate is fixed.

VI. CONCLUSION

The results of the performance study reveal that the developed system works properly with an excellent accuracy. One target of the system is to keep temperature of a device constant. A microcontroller chip 16F877A is used and it has a 256 bytes data EEPROM memory. So, this system can store up to 128 data. The LCD used in this system can display the stored data in EEPROM when the specific switch is pressed. Thus we can collect and analyze the data when necessary.

The other target of the system is to provide economic benefit to its users. Cheap and available components are used to design the system. The size of

the system is small. Two ways - power and small size make the device portable. So, it can be easily carried and implemented anywhere.

The efficiency of the system is satisfactory. The A/D converter module has a high resolution and thus the accuracy of the system is nearly perfect.

REFERENCES RÉFÉRENCES REFERENCIAS

1. Ben G. Streetman, Sanjay Banarjee, *Solid State Electronic Devices*, 5th Edition, India: Prentice-Hall India, 2001.
2. Gary F. McGuire, *Semiconductor Materials and Process Technology Handbook*, 6th edition, India: Jaico Publishing House, 2008.
3. Lim K. W., Luo J., Gu J., Poh Y. P., Tan W. W. and Loh A. P., Integrated in-line temperature measurement system for silicon wafer semiconductor manufacturing, The 25th Annual Conference of the IEEE Industrial Society, Vol.: 1, pp.: 6 – 10, IECON '99.
4. Tay A., Ho W. K., Loh A. P., Lim K. W., Tan W. W. and Schaper C. D., Integrated bake/chill module with in situ temperature measurement for photoresist processing, Semiconductor Manufacturing, IEEE Transactions, Vol.: 17, Issue: 2, pp.: 231 – 242,, May 2004.
5. Cole-Parmer data sheet for hot plates. 625 East Bunker Court Vernon Hills, IL 60061 USA, [Online], Available: <http://datasheets.globalspec.com/ds/2679/ColeParmer>, [Accessed: November, 2009]
6. D. Ibrahim "Teaching digital control using a low cost microcontroller-based temperature control kit" International Journal of Electrical Engineering Education, Department of computer engineering, Near East University, Lefcoca, Turkey.
7. "Photoresist Coating Hood" Northwestern University Micro/Nano Fabrication Facility (NUFAB) <http://nufab.northwestern.edu/sites/default/files/training/spinner/%20Hood.pdf>
8. Rolf Enderlein, Norman J. M Horing, *Fundamentals of semiconductor physics and devices*, 1st edition, Singapore: World Scientific Publishing Co Pte Ltd, 1997.
9. "Low Temperature Annealing System for 300mm Wafers", woo sik yoo, Taro Yamazaki, Toshiyuki Uchino, WaferMasters, Inc. 246 East Gish Road, San Jose, CA 95112 USA, *Trecenti Technologies, Inc. 751 Horiguchi, Hitachinaka, Ibaraki 312-0034, Japan
10. "The effect of pulse width modulation (PWM) frequency on the reliability of thermoelectric modules", Michael j. nagy and Steven j. roman, TE technology, Inc. 1590 keani drive, Traverse city, Michigan 49686 USA. ICT99MJN.
11. Martin Bates, *Interfacing PIC Microcontrollers Embedded Design by Interactive Simulation*, 1st edition, Great Britain: Elsevier, 2006.
12. WinPicProg PIC Tutorial, November 12 , 2009, [Online]. Available: http://www.winpicprog.co.uk/pic_tutorial.htm, [Accessed: November 2009].
13. J. Iovine, *PIC Microcontroller Project Book*, 1st edition, USA: McGraw-Hill, 2000.
14. Robert L. Boylestad, Louis Nashelsky, *Electronic Devices and Circuit Theory*, 7th Edition, India: Prentice Hall, 2003.
15. November 12, 2009, [Online], Available: http://www.mikroelektronika.co.yu/english/product/books/PICbook/0_Uvod.htm, [Accessed: November, 2009].