



GLOBAL JOURNAL OF RESEARCHES IN ENGINEERING  
ELECTRICAL AND ELECTRONICS ENGINEERING  
Volume 13 Issue 10 Version 1.0 Year 2013  
Type: Double Blind Peer Reviewed International Research Journal  
Publisher: Global Journals Inc. (USA)  
Online ISSN: 2249-4596 & Print ISSN: 0975-5861

## High Performance Fuzzy Adaptive Control for D.C. Motor

By Ravinder Kumar & Vineet Girdha

*Khalsa Institute of Engineering & Technology, India*

*Abstract* - This paper presents speed control of a separately excited DC motor using fuzzy logic control (FLC) based on MATLAB Simulation program. This method of speed control of a dc motor represents an ideal application for introducing the concepts of fuzzy logic. The paper shows how a commercially available fuzzy logic development kit can be applied to the theoretical development of a fuzzy controller for motor speed, which represents a very practical class of engineering problems. From this it is seen that the simulation results are similar to the theoretical results which achieve the optimum control.

*Keywords* : DC motor control, fuzzy logic controller, MATLAB simulation program.

*GJRE-F Classification* : FOR Code: 090699



*Strictly as per the compliance and regulations of :*



# High Performance Fuzzy Adaptive Control for D.C. Motor

Ravinder Kumar<sup>α</sup> & Vineet Girdha<sup>σ</sup>

**Abstract** - This paper presents speed control of a separately excited DC motor using fuzzy logic control (FLC) based on MATLAB Simulation program. This method of speed control of a dc motor represents an ideal application for introducing the concepts of fuzzy logic. The paper shows how a commercially available fuzzy logic development kit can be applied to the theoretical development of a fuzzy controller for motor speed, which represents a very practical class of engineering problems. From this it is seen that the simulation results are similar to the theoretical results which achieve the optimum control.

**Keywords** : DC motor control, fuzzy logic controller, MATLAB simulation program.

## I. INTRODUCTION

Classic Control has proven for a long time to be good enough to handle control tasks on system control; however his implementation relies on an exact mathematical model of the plant to be controlled and not simple mathematical operations. The fuzzy logic, unlike conventional logic system, is able to model inaccurate or imprecise models. The fuzzy logic approach offers a simpler, quicker and more reliable solution that is clear advantages over conventional techniques. Fuzzy logic may be viewed as form of set theory. At the present time, MATLAB Simulation simplifies the scientific computation, process control, research, industrial application and measurement applications. Because MATLAB has the flexibility of a programming language combined with built-in tools designed specifically for test, measurement and control. By using the integrated MATLAB environment to interface with real-world signals, analyze data for meaningful information and share results. Therefore take MATLAB for development of the control system that append with fuzzy logic is incoming for modern control and the advantages in fuzzy control are more robust control method than usual conventional control to variation of system parameter. This paper presents the experimental results of the fuzzy logic controller using Matlab for speed control of Separately Excited DC Motor through fuzzy logic controller for speed control is used to facilitate and efficiency the implementation of controllers.

**Authors α, σ** : Department of Electrical Engineering, Guru Teg Bhadur Khalsa Institute of Engineering & Technology, Malout, India.  
E-mails : ravinder\_fdk@yahoo.co.in, vineet2833@yahoo.co.in

## II. SYSTEM DESCRIPTION

### a) Motor Model

The resistance of the field winding and its inductance of the motor used in this study are represented by  $R_f$  and  $L_f$  respectively in dynamic model. Armature reaction effects are ignored in the description of the motor. This negligence is justifiable to minimize the effects of armature reaction since the motor used has either interpoles or compensating winding. The fixed voltage  $V_f$  is applied to the field and the field current settles down to a constant value. A linear model of a simple DC motor consists of a mechanical equation and electrical equation as determined in the following equations (1) - (2).

$$T_m = J_m d\omega/dt + B_m \omega + T_L \quad (1)$$

$$V_a = E_b + I_a R_a + L_a (dI_a/dt) \quad (2)$$

Where

$V_a$  is the armature voltage. (In volt)

$E_b$  is back emf the motor (In volt)

$I_a$  is the armature current (In ampere)

$R_a$  is the armature resistance (In ohm)

$L_a$  is the armature inductance (In henry)

$T_m$  is the mechanical torque developed (In Nm)

$J_m$  is moment of inertia (In kg/m<sup>2</sup>)

$B_m$  is friction coefficient of the motor (In Nm/(rad/sec))  $\omega$  is angular velocity (In rad/sec) The dynamic model of the system is formed using these differential equations.

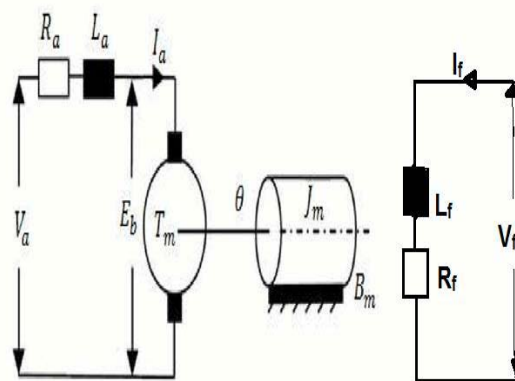

Figure 1 : Separately Excited DC Motor Model

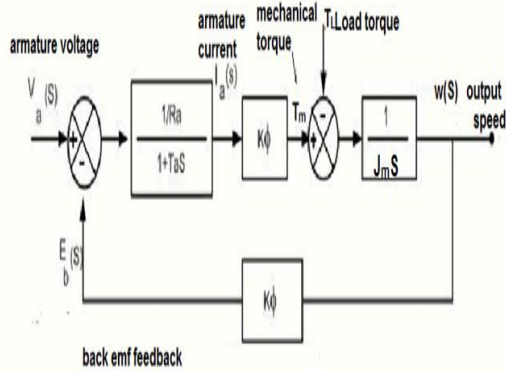

Figure 2 : Block Model of Separately Excited DC Motor

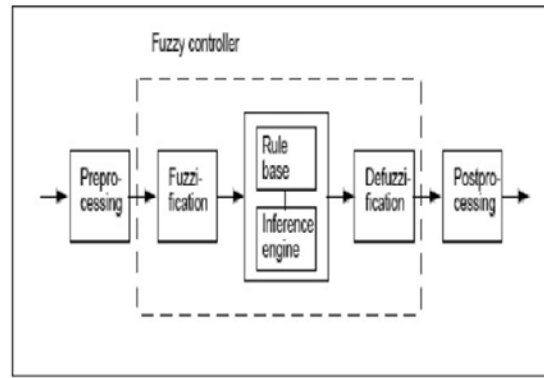

Figure 3 : Structure of fuzzy logic controller

### III. FUZZY LOGIC CONTROLLER

Fuzzy logic is a method of rule-based decision making used for expert systems and process control that emulates the rule-of-thumb thought process used by human beings. The basis of fuzzy logic is fuzzy set theory which was developed by Lotfi Zadeh in the 1960s. Fuzzy set theory differs from traditional Boolean (or two-valued) set theory in that partial membership in a set is allowed. Traditional Boolean set theory is two-valued in the sense that a member belongs to a set or does not and is represented by 1 or 0, respectively. Fuzzy set theory allows for partial membership or a degree of membership, which might be any value along the continuum of 0 to 1. A linguistic term can be defined quantitatively by a type of fuzzy set known as a membership function. The membership function specifically defines degrees of membership based on a property such as temperature or pressure. With membership functions defined for controller or expert system inputs and outputs, the formulation of a rule base of IF-THEN type conditional rules is done. Such a rule base and the corresponding membership functions are employed to analyze controller inputs and determine controller outputs by the process of fuzzy logic inference. By defining such a fuzzy controller, process control can be implemented quickly and easily. Many such systems are difficult or impossible to model mathematically, which is required for the design of most traditional control algorithms. In addition, many processes that might or might not be modeled mathematically are too complex or nonlinear to be controlled with traditional strategies. However, if a control strategy can be described qualitatively by an expert, fuzzy logic can be used to define a controller that emulates the heuristic rule-of-thumb strategies of the expert. Therefore, fuzzy logic can be used to control a process that a human can control manually with expertise gained from experience. The linguistic control rules that a human expert can describe in an intuitive and general manner can be directly translated to a rule base for a fuzzy logic controller.

### IV. PROBLEM FORMULATION

A Separately Excited DC motor is taken as a case study and the control is achieved using intelligent fuzzy logic based controller. The efficiency is improved by controlling the speed with fuzzy logic controller and results are shown graphically.

#### a) Fuzzy Logic Controller Design

The inputs to the Self-tuning Fuzzy Controller are speed error "e (t)" and Change-in-speed error "de (t)". The input shown in figure are described by

$$e(t) = w_r(t) - w_a(t)$$

$$de(t) = e(t) - e(t-1)$$

Using fuzzy control rules the output control is adjusted, which constitute the self control of D.C. machine.

### V. ADJUSTING FUZZY MEMBERSHIP FUNCTIONS AND RULES

In order to improve the performance of FLC, the rules and membership functions are adjusted. The membership functions are adjusted by making the area of membership functions near ZE region narrower to produce finer control resolution. On the other hand, making the area far from ZE region wider gives faster control response. Also the performance can be improved by changing the severity of rules.

#### a) Design of Membership Function (MF)

##### i. Input Variables

##### a. Fuzzy Sets of Speed Error (E) Variable

Table 1: Membership function of speed error

Fuzzy Set Error	Numerical Range	Shape of membership function
Very Low	0.2 to 0.5 1 to 1	Trapezoidal
Instant	-0.01 to 0 0 to 0.01	Triangular

Very High	-1 to -1 -0.5 to -0.2	Trapezoidal
Very Medium Low	0 to 0.2 0.2 to 0.4	Triangular
Very Medium High	-0.4 to -0.2 -0.2 to -0	Triangular

b. Fuzzy Sets of Change in Speed Error (De) Variable

Table 2 : Membership function of change in speed error

Fuzzy Set derivative of Error	Numerical Range	Shape of membership function
High Negative	-1 to -1 -1 to 0	Triangular
Error High Positive	0 to 1 1 to 1	Triangular

b) Output Variables

i. Fuzzy Set for Control

Table 3 : Fuzzy Set for Control

Output	Numerical Range	Shape of membership function
Decrease A lot	-30 to -25 -25 to -20	Triangular
Increase A lot	20 to 25 25 to 30	Triangular
Decrease Few	-15 to -10 -10 to -5	Triangular
Hold	-0.1 to 0 0 to 0.1]	Triangular
Increase Few	5 to 10 10 to 15	Triangular

c) Design of Fuzzy Rules

i. Rule bases for Output Control

e/de	Very High	Medium High	Instant	Medium Low	Very Low
High Negative	Decrease alot	Decrease few	Decrease few	Increase few	Increase alot
High positive	Decrease alot	Decrease few	Increase few	Increase few	Increase alot
			Hold		

Figure 4 : Rule bases for output control

VI. MATLAB SIMULATION

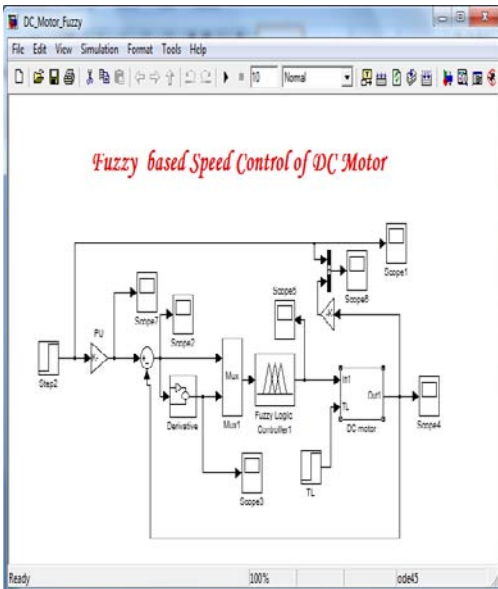

Figure 5 : SIMULINK model of fuzzy control D.C. machine

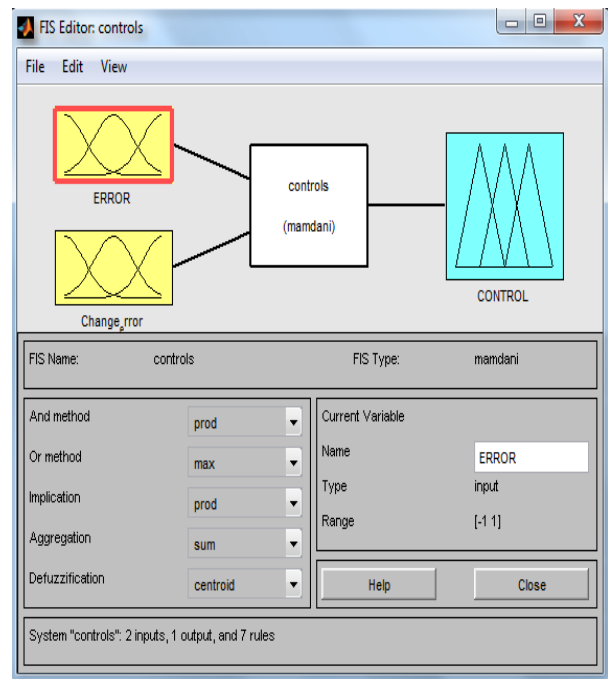

Figure 6 : FIS Editor

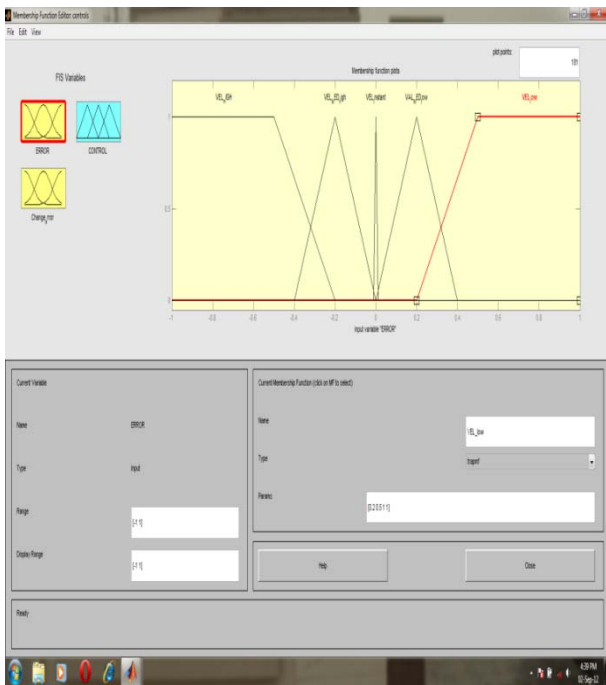

Figure 7 : Membership function for input variable “e”

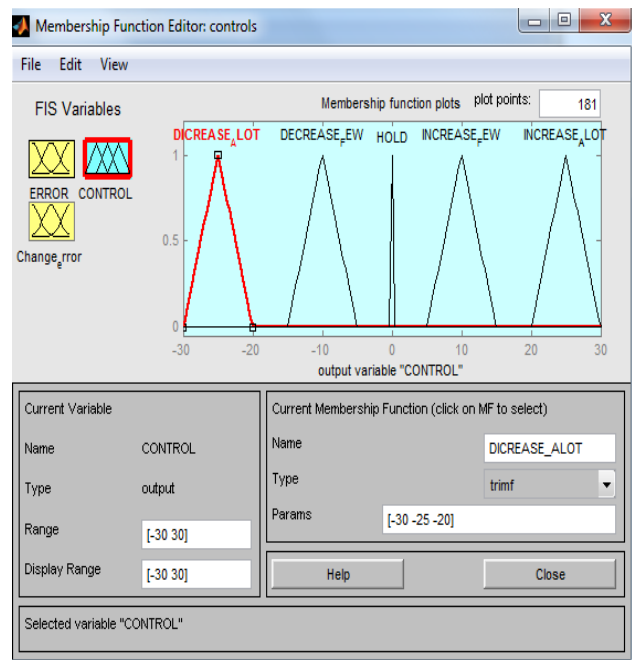

Figure 9 : Membership function for output variable “Controls”

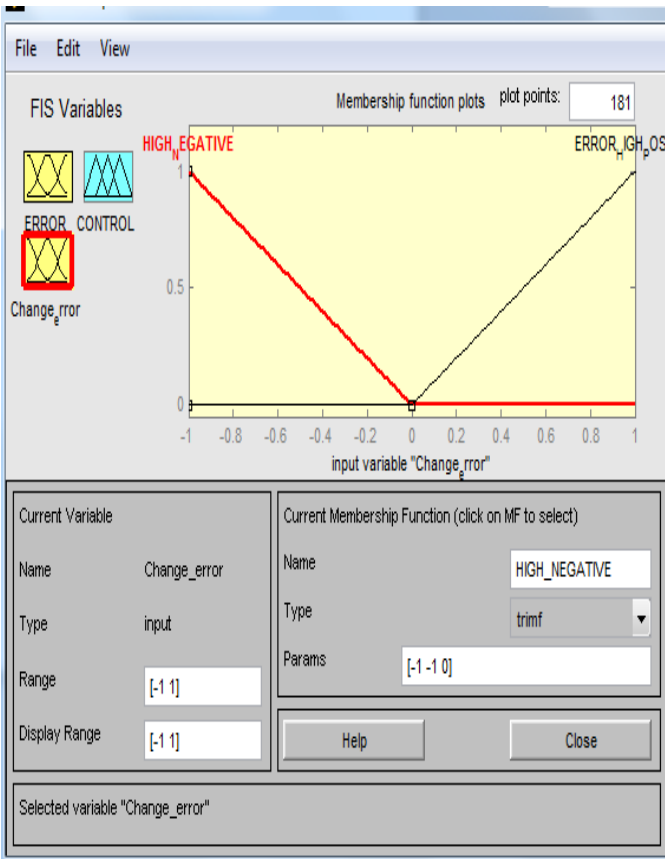

Figure 8 : Membership function for input variable “de”

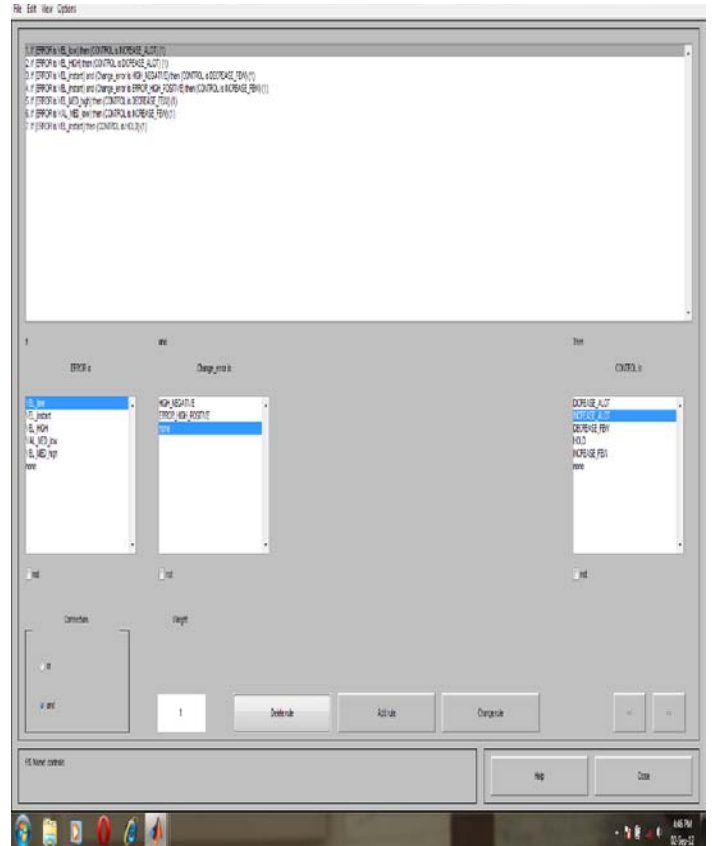

Figure 10 : Rule Editor

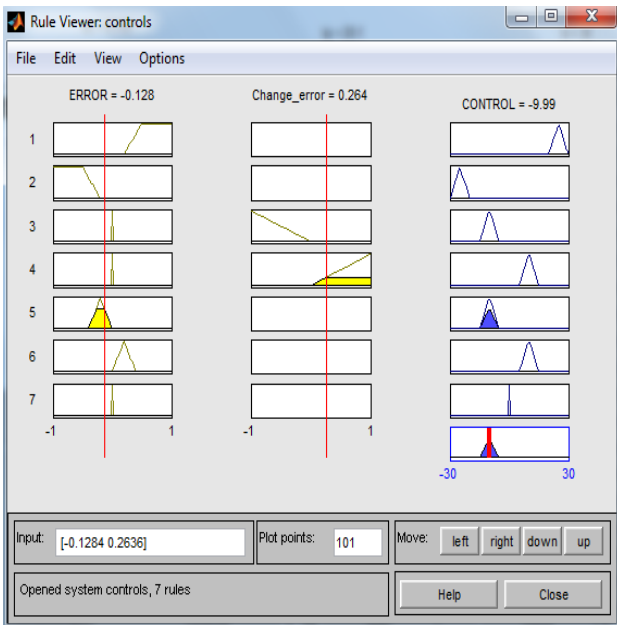

Figure 11 : Rule Viewer

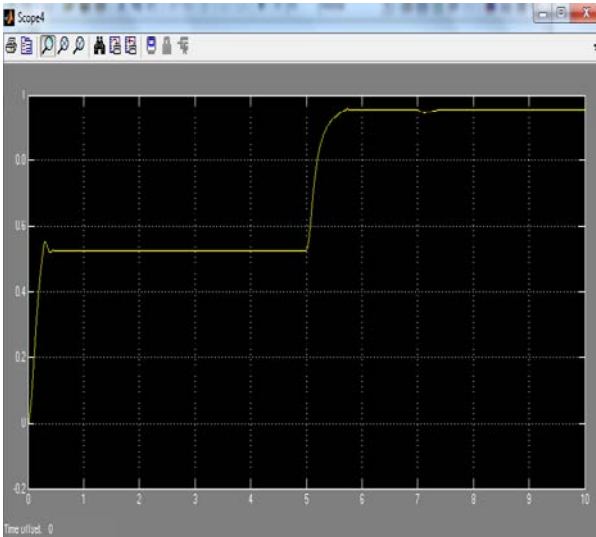

Figure 12 : Output of the System



Figure 13 : Output of fuzzy logic controller

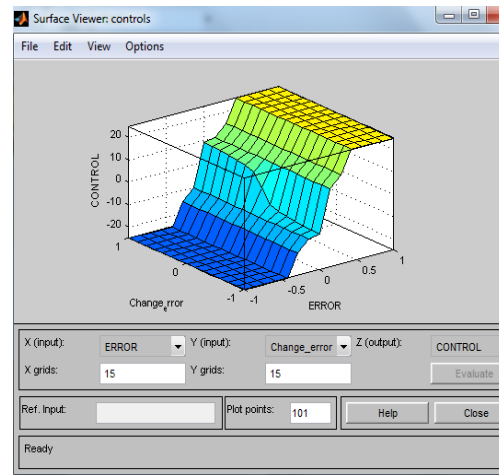

Figure 14 : Surface view for controls

## VII. CONCLUSION

This paper proposes a straight-forward method of creating a mathematical model which has been successfully applied to a variety of membership functions. This new approach offers a key of advantage over the traditional methods, which makes it suitable for several dc motor drive applications. The paper focused the attention to apply the smooth control of speed in D.C. Machines up to the 95% and with minimization of speed error. The simulation and experimental studies clearly indicate the superior of fuzzy control. It is well seen in the case of sudden change due to load torque disturbances because it is inherently adaptive in nature. The final experimental results clarify the success, the simplicity and the generality of the design software controller. The extension of this research is to apply the neural network techniques for the dc motor applications.

## REFERENCES RÉFÉRENCES REFERENCIAS

1. Lee, C.C.; "Fuzzy logic in control systems: fuzzy logic controller. I," Systems, Man and Cybernetics, IEEE Transactions on, vol.20, no.2, pp.404-418, Mar/Apr 1990.
2. Malhotra Rahul; Kaur Tejbeer; "DC Motor control using fuzzy logic controller" (IJAEST) INTERNATIONAL JOURNAL OF ADVANCED ENGINEERING SCIENCES AND TECHNOLOGIES vol. No. 8, Issue No. 2, 291 – 296.
3. Sousa, G.C.D.; Bose, B.K.; "A fuzzy set theory based control of a phase-controlled converter DC machine drive," Industry Applications, IEEE Transactions on, vol.30, no.1, pp.34-44, Jan/Feb 1994.
4. Costa Branco, P.J.; Dente, J.A.; "An experiment in automatic modeling an electrical drive system using fuzzy logic," Systems, Man, and Cybernetics, Part C: Applications and Reviews, IEEE Transactions on, vol.28, no.2, pp.254-262, May 1998.
5. Ahmed, F.I.; Mahfouz, A.A.; Ibrahim, M.M.; "A novel fuzzy controller for DC motor drives," Electrical

Machines and Drives, 1999. Ninth International Conference on (Conf. Publ. No. 468), vol., no., pp.325-328, 1999.

6. Aydemir, S.; Sezen, S.; Ertunc, H.M.; "Fuzzy logic speed control of a DC motor," Power Electronics and Motion Control Conference, 2004. IPEMC 2004. The 4th International, vol.2, no., pp.766-771 Vol.2, 14-16 Aug. 2004.

