



GLOBAL JOURNAL OF RESEARCHES IN ENGINEERING: F
ELECTRICAL AND ELECTRONICS ENGINEERING
Volume 16 Issue 5 Version 1.0 Year 2016
Type: Double Blind Peer Reviewed International Research Journal
Publisher: Global Journals Inc. (USA)
Online ISSN: 2249-4596 & Print ISSN: 0975-5861

Intelligent Solar based Gesture Controlled Wireless Wheelchair for the Physically Handicapped

By Mayank Shadwani, Sachin Singh, Vinay Kumar Verma & Shivani Sachan

Shri Ram Murti Smarak College of Engineering & Technology

Abstract- This document presents a wide new way of handling a wheelchair. The wheelchairs which were being used in the present time are controlled by the persons sitting over them. The person sitting over the chair has to exert a force by his hands in order to move the chair and get to the desired location. So for the sake of the handicapped persons, a new implementation is going to be made on the wheelchair which enables the person to move the chair without applying any kind of force. The person just has to make a simple gesture using his body part (for example: hand) to move the chair. This application is done using the microcontroller and the accelerometer sensor. The physically handicapped people will have the option of controlling the system through hand gesture wirelessly from ranges up to several meters and will have the independence of using the wheelchair without the help of any other people. The project includes the locomotion of the wheelchair without the application of any external force. This application is done using triple axis accelerometer sensor and the complete phenomenon is made wireless by using RF modules.

Keywords: wireless control, gesture control, solar energy, distress call system (DCS).

GJRE-F Classification : FOR Code: 090605



Strictly as per the compliance and regulations of :



© 2016. Mayank Shadwani, Sachin Singh, Vinay Kumar Verma & Shivani Sachan. This is a research/review paper, distributed under the terms of the Creative Commons Attribution-Noncommercial 3.0 Unported License (<http://creativecommons.org/licenses/by-nc/3.0/>), permitting all non commercial use, distribution, and reproduction in any medium, provided the original work is properly cited.

Intelligent Solar based Gesture Controlled Wireless Wheelchair for the Physically Handicapped

Mayank Shadwani ^α, Sachin Singh ^σ, Vinay Kumar Verma ^ρ & Shivani Sachan ^ω

Abstract- This document presents a wide new way of handling a wheelchair. The wheelchairs which were being used in the present time are controlled by the persons sitting over them. The person sitting over the chair has to exert a force by his hands in order to move the chair and get to the desired location. So for the sake of the handicapped persons, a new implementation is going to be made on the wheelchair which enables the person to move the chair without applying any kind of force. The person just has to make a simple gesture using his body part (for example: hand) to move the chair. This application is done using the microcontroller and the accelerometer sensor. The physically handicapped people will have the option of controlling the system through hand gesture wirelessly from ranges up to several meters and will have the independence of using the wheelchair without the help of any other people. The project includes the locomotion of the wheelchair without the application of any external force. This application is done using triple axis accelerometer sensor and the complete phenomenon is made wireless by using RF modules. The person sitting on the chair just has to make a gesture using his hand and according to the process the chair will move in forward, reverse, right, left and stop. Also the chair stops moving when there is any obstacle is in front of the chair. All this implementation will add just a little cost in the wheelchair. One more advantage of this chair is that it operates on the solar energy. So there is no problem of cost of the electricity consumption. On the successful implementation of the mini prototype of proposed model, we found that the chair is moving perfectly as per the command through the gesture made by the hands. In the further advancing technology, we are going to interface this chair with the GPS modules and Bluetooth modules, so the handicapped person can be traced and so that the wheelchair has the calling facility on itself. So it is a complete package for sake of handicapped persons at an affordable price.

Keywords: wireless control, gesture control, solar energy, distress call system (DCS).

I. INTRODUCTION

The project displays the feature of the wireless controlling of the objects. In the present project, a very new way of handling a wheelchair by the application of the accelerometer sensor. We all know that while driving the wheelchair the person has to exert

a force on the wheels so that the wheelchair can move in the desired direction. To achieve this performance the application involves the use of the *triple axis accelerometer sensor (ADXL335)*. Also for the controlling purpose, microcontroller is employed in the circuit. People with physical disabilities and partial paralysis always find it difficult to navigate through their habitat or their home without the assistance of someone. Often after paralysis or physical disability the wheelchair is the most common means of locomotion for such people. But to navigate through one's own house without help of someone every time can be demoralizing for the person as well.

With the present development on the field of robotics, embedded system and artificial intelligence a successful project has been developed in order to easily solve this matter and that too at a very low cost. The wheelchair in context can be remotely controlled from several meters wirelessly without actually sitting on it. The chair can be controlled by hand gesture method with directions as needed. The recognition of hand gestures requires both hand's detection and gesture's recognition. Both tasks are very challenging, mainly due to the variability of the possible hand gestures (signs), and because hands are complex, deformable objects (a hand has more than 25 degrees of freedom, considering fingers, wrist and elbow joints) that are very difficult to detect in dynamic environments with cluttered backgrounds and variable illumination.

Several techniques have been discovered so far to trace the position of the hands and turn them into the corresponding voltage level. The standard input methods, such as text input via the keyboard and pointer/location information from a mouse, do not provide a natural interaction between humans and machines. Therefore, it is essential to create models for natural communication between humans and machines. The ability to understand hand gestures will improve the naturalness and efficiency of human interaction with machine, and allow the user to communicate in complex tasks.

The proposed model makes the wheelchair a lot easier to assemble and simple in the use, in addition the cost of manufacturing also gets reduced. Also, with this development the wheelchair can be controlled remotely from several meters away. So a person sitting on the

Author ^α ^σ ^ρ ^ω: Electronics & Communication Engineering, Shri Ram Murti Smarak College of Engineering & Technology Unnao, Uttar Pradesh, India. e-mails: mayank.shadwani11@gmail.com, shivanisachan7@gmail.com

sofa can control the wheelchair near or away from him just by hand gestures. It can also help people during the night without the need for a third person; for the person to get on the wheelchair and move inside the house. People will also be able to control the chair in narrow spaces without collision as the system uses ultrasonic sensors and proximity sensors to avoid the objects. This technique of avoiding the obstacles in the path permits the person sitting on the wheelchair to move freely without having any tension of falling down or striking to any wall or obstacle. The only reason behind developing this model is to make handicapped peoples tension free. They don't require anyone's help to go anywhere. All what they have to do is to give command to the chair using their working body parts. Also a great advantage is that this implementation will add just a little cost in the original manufacturing cost of the wheelchair, so that anyone can afford this wheelchair.

II. BLOCK DIAGRAM

The main aim of the project is to allow the physically challenged peoples to move the wheelchair without the help of anyone. Because of this development such peoples can easily move anywhere in their homes without having any fear of getting struck by any obstacle. This model consists of controlling the wheelchair with the use of the gesture sensors and the microcontroller unit. The output from the hand gestures modules gives command to the microcontroller. The whole technology is made wireless just by employing a transmitter and a receiver module which gives a reduction in the complexity of the circuit arising because of the wires. For wireless communication RF modules are used. The following block diagram shows how the entire system working:

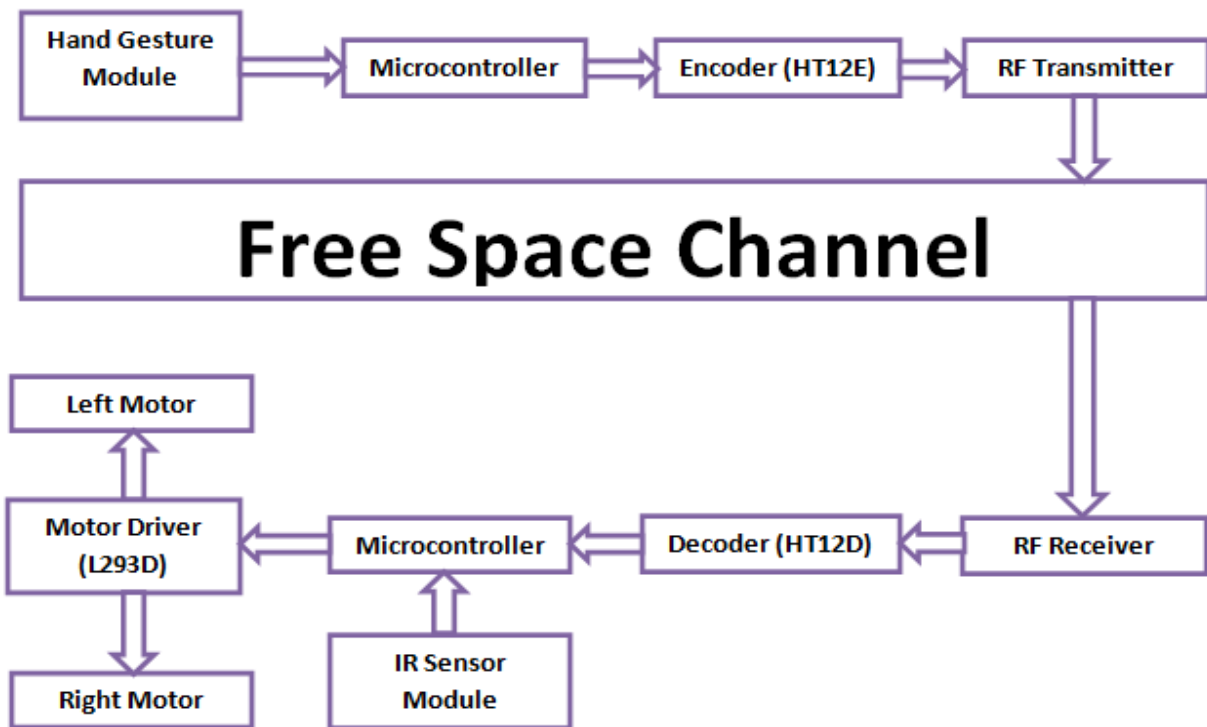

Figure 1 : Block diagram of the system

As the block diagram shows, the input signal is received from the accelerometer sensor, and then the output of the sensor is given to the RF transmitter module. As we are concerned with the wireless technology, so here we have employed RF modules. The transmitted wave travels through the channel and reach to the receiver module. The receiver gives the output which is originally fed to the system. The output of the system is given to the microcontroller which is mainly responsible for the entire controlling phenomenon. Here we have used PIC microcontroller. Motion control, edge detection and obstacle avoiding processes are controlled by the microcontroller. Now we

will move towards the discussion of the components used in the system.

III. SYSTEM HARDWARE

The system uses various components which are important for the system to work in the proper manner. The description about the various components is as follows:

a) Solar Panel

Solar energy is used to give supply to the whole system. As we are concerned with the affordable use of the system so we have employed solar energy instead

of the main electricity. A battery of 12V 1.5AH is used for the backup so that the chair can work in night time also. The charging circuitry includes the switching diode (1N4148) in parallel to the capacitor. In addition to this a

15V regulator IC (7815) is also used to regulate the voltage coming from the panel. The output of the regulator IC is given to the battery.

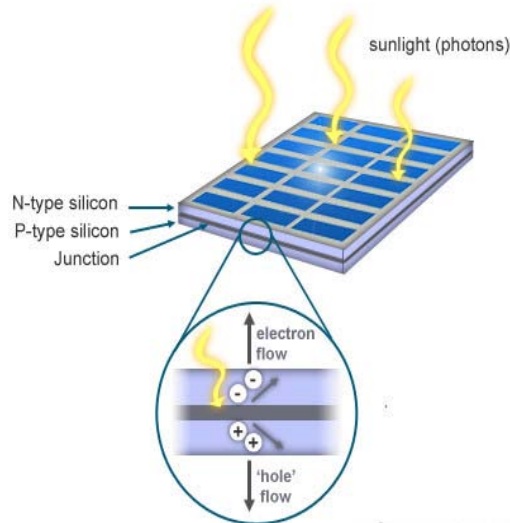

Figure 2 : Working of a solar panel



Figure 3 : Battery used for backup purpose

b) Hand Gesture Module

The module which is being used here for detecting the gestures made by hand is a triple axis accelerometer sensor (ADXL335) which measures the

three dimensional position of the hand. The output from the accelerometer is an analog voltage which is further converted in the corresponding digital voltage with the help of ADC (Analog to Digital Converter).



Figure 4 : View of the Hand Gesture Module used for controlling the locomotion

The accelerometers are used in many applications and are of many types depending upon the

axis. The accelerometer sensor senses the accelerating force (acceleration due to gravity or g) and thus gives a



particular voltage for the x, y and z coordinate orientation. The data can be observed in integer format through the serial port of MCU (Microcontroller Unit) on the computer's serial monitor and accordingly the orientations of the hand can be sorted out. Accelerometer sensors convert either linear or angular acceleration to an output signal. Accelerometer sensors use Newton's second law of motion.

$$\text{Force} = \text{mass} \times \text{acceleration}$$

If the force and mass on the body are known, then we can calculate the accelerating force acting on the body. Thus, by this equation the acceleration due to gravity is determined. As we know that acceleration is defined by the rate of change of velocity per unit time.

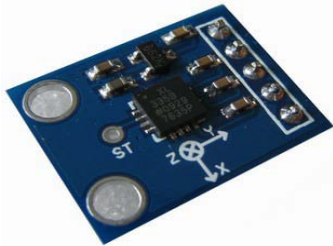

Figure 5 : Accelerometer Sensor (ADXL335)

c) Microcontroller

Microcontroller is such a thing which is used to control any system according to the requirement of the user. Microcontroller is rather different from the microprocessor. In the microcontroller, there is no option to attach external memories to the devices. Since we are concerned with the small application and didn't require large memory so here we have employed a microcontroller. Microcontrollers are of different series and need to be programmed as per the requirement of the application. The different classes of MCU available in the market are: **8051, AVR, & PIC**. Here in this project we have used AVR series MCU. Microcontroller is the main device which is used to control the entire phenomenon.

d) Encoder & Decoder

Encoder (HT12E) and decoder (HT12D) are used in the system for the purpose of encoding the signal at the transmitter end and decoding the signal at the receiver end. The encoder generates serial codes that are automatically sent three times and must be received at least twice before data is accepted as valid by the decoder circuit.

e) Radio Frequency Module

The RF transmitter module has been used as per the purpose of making the gesture module completely wireless. We are using a 434MHz WS-TX-01 module for the transmitting purpose. For a specific orientation of the hand the MCU on the hand decides the condition and a particular character are sent to

receiver module. For the receiver we are using a 434MHz WS-RX-02 module which is a low cost receiver module. The receiver upon receiving the string sends the data to the microcontroller on the wheelchair which in turn decides the case of the locomotion of the wheelchair. The RF module works on the principle of Amplitude Shift Keying (ASK) modulation technique. The entire module is very effective for long distances.



Figure 6 : 433.92MHz RF Modules (Transmitter & Receiver)

f) Locomotion

For the locomotion purpose we are using a L293D motor driver IC. As the output current of microcontroller is low and it is not sufficient to drive the motor so driver IC is used. ULN2003 can also be used for this purpose. The motors are controlled by the bidirectional motor driver IC. The motor driver is connected through the microcontroller on the wheelchair which sends the signal to the driver for various conditions. For smooth turning during the motion of the wheelchair we have used the method of PWM. The Pulse Width Modulation (PWM) allows the microcontroller to send the power to the motor driver in small packets over high frequency. The constant ON and OFF states actually helps to conduct smooth turning operation. Motor drivers act as current amplifiers since they take a low-current control signal and provide a higher-current signal. This higher current signal is used to drive the motors.

g) Edge Detection Module

For this purpose we have employed IR sensors module to avoid the edges. An Infrared (IR) sensor is used to detect obstacles in front of the chair or to differentiate between colours depending on the configuration of the sensor. An IR sensor consists of an emitter, detector and associated circuitry. The emitter is simply an IR LED (Light Emitting Diode) and the detector is simply an IR photodiode which is sensitive to IR light of the same wavelength as that emitted by the IR LED. When IR light falls on the photodiode, its resistance and correspondingly, its output voltage, change in proportion to the magnitude of the IR light received. This is the underlying principle of working of the IR sensor.

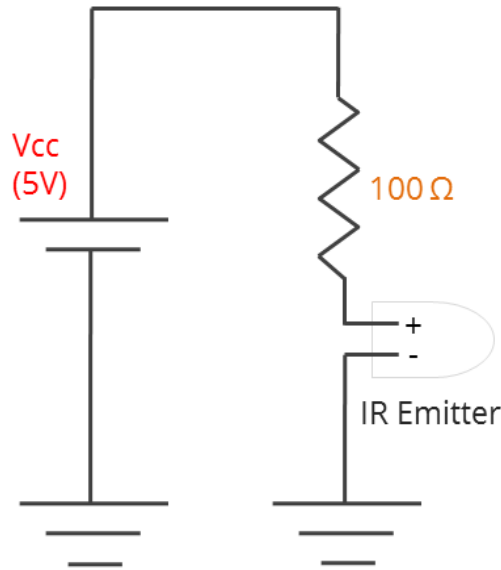

Figure 7 : Emitter Circuit

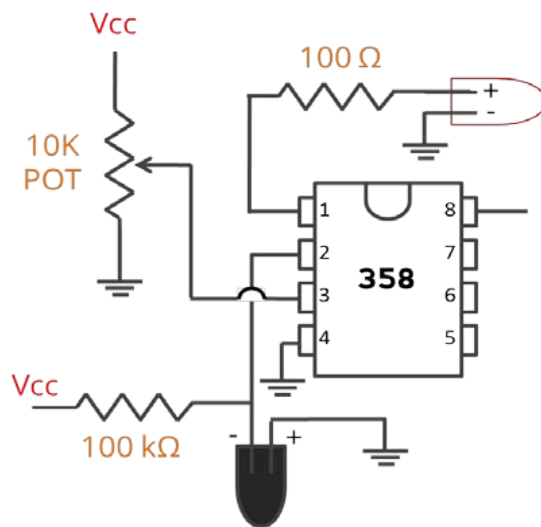

Figure 8 : Detector Circuit

h) Distress Call System

For the case of emergency of the handicapped person an emergency call system is used by implementing the circuit with the SIM module. The distress call system is used along with the gesture command system. On the sensation of malfunction or if there is an emergency situation the person can send an SOS distress message by GSM controlled SIM 900 module on the wheelchair. The hand module in gesture control has a switch which if pressed, sends a digital high signal to the MCU on the hand which in turns sends the signal wirelessly to the receiver module on the wheelchair and then to the SIM900 module. The module then send the distress SMS to the already inserted numbers of people at the same time.

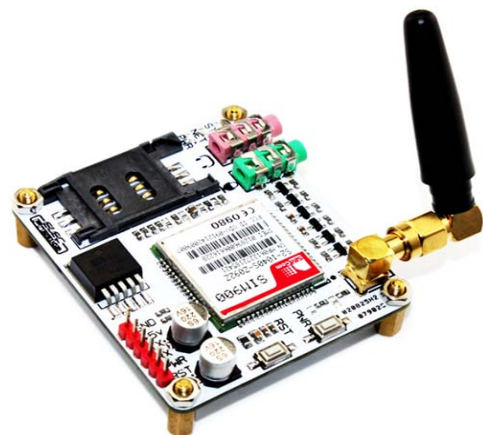

Figure 9 : GSM900 Module



IV. RESULTS AND DISCUSSIONS

All the components after integration give us the working skeleton model for the wheelchair. The wheelchair model works perfectly according to the hand gestures. The reaction time of the various modules as noticed after the several trial runs are tabulated below. The readings are calculated based on the following formula:

$$\text{Success Rate} = (\text{Number of successful trails} * 100) / \text{Total number of trials}$$

Along with that we also noticed that the communication of the wireless module extends over

several meters in the indoors. Rather than the constricted need of the person to be on the wheelchair the entire time to control it, the developed idea works absolutely free of any wires or any restrictions. The ability to avoid the obstacles is kept to the limit of 5cm from the wheelchair. If detected the wheelchair turn the other direction from the obstacle still it is back on the front line. The various gestures were tested and the outputs were studied to check if the right codes are transmitted. The mobile wheelchair is capable of sending over the air how close it was to the nearest object at its right, left and centre.

Table1 : Results obtained from observations

S.No.	Parameters	Success Rate
1.	Gesture Change	94%
2.	Distress Alert	100%
3.	Edge Detection & Avoiding	100%

V. FINAL VIEW OF THE PROTOTYPE



Figure 10 : View of the prototype made for testing different parameters

V. CONCLUSION

With the development of the project it can be successfully implemented on a larger scale for the handicapped people. The low cost of the assembly makes it really a bonus for the general public. The wireless system will be a boost to the confidence and willpower of physically challenged people as it will help them to be self-reliable. As a part of further development the project can be developed with addition voice recognition features. There can also be the application of intelligent home navigation for handicapped people to go through the entire house and get help from technological interface for the navigation. The object avoiding and careful navigation principle can be improved with algorithm based image processing technology.

REFERENCES RÉFÉRENCES REFERENCIAS

1. Sudheer kanuri, T V Janardhana Rao, Ch Sridevi and M S Madhan Mohan, "Voice and Gesture Based Electric-Powered Wheelchair Using ARM", IJRCCT, Vol 1, Issue 6, November 2012
2. Rajesh Kannan Megalingam, Sai Manoj Prakhya, Ramesh Nammily Nair and Mithun Mohan, "Unconventional Indoor Navigation: Gesture Based Wheelchair Control", 2011 International Conference on Indoor Positioning and Indoor Navigation (IPIN), Available: http://ipin2011.dsi.uminho.pt/PDFs/Shortpaper/101_Short_Paper.pdf
3. R. Lockton and A.W. Fitzgibbon, "Real-time gesture recognition using deterministic boosting", Proceedings of British Machine Vision Conference (2002).
4. V.Bonato, A.Sanches, M.Fernandes, J.Cardoso, E.Simoes, and E.Marques, "A Real Time Gesture Recognition System for Mobile Robots", International Conference on Informatics in Control, Automation, and Robotics, August 25-28, Portugal, 2004, INSTICC, pp. 207-214.
5. R.H. Liang, M. Ouhyoung, a real-time continuous gesture recognition system for sign language Face and Gesture Recognition, 1998, pp.558-565.
6. Dr. Gowri Shankar Rao, Dr. D. Bhattacharya, Ajit Pandey and Aparna Tiwari, "Dual Sensor Based Gesture Robot Control Using Minimal Hardware System", International Journal of Scientific and Research Publications, Volume 3, Issue 5, May 2013
7. R.Posada Gomez, L.H.Sanchez Medel, "A Hand Gesture System of Control For An Intelligent Wheelchair", Proc.ICEEE,P.68-71,5-7,Sept.2007.
8. S VAN DELDEN, "VISUAL DETECTION OF OBJECTS IN A ROBOTIC WORK AREA USING HAND GESTURES", IEEE INTERNATIONAL SYMPOSIUM ON ROBOTIC AND SENSORS ENVIRONMENTS (ROSE), 2011
9. Nguyen Kim-Tien, Nguyen Truong and Trinh Duc Cuong, "A Method for Controlling Wheelchair Using Hand Gesture Recognition", Robot Intelligence Technology and Applications 2012 - Advances in Intelligent Systems and Computing Volume 208, 2013, pp 961-970.

This page is intentionally left blank

