

# GLOBAL JOURNAL

OF SCIENCE FRONTIER RESEARCH: A

## Physics and Space Science



Philosophy of Wave Reference

Application of Electrical Resistivity

Highlights

Conceptual Problems in Geometry

Thermal Explosion Characteristics

Discovering Thoughts, Inventing Future

VOLUME 16    ISSUE 6    VERSION 1.0



GLOBAL JOURNAL OF SCIENCE FRONTIER RESEARCH: A  
PHYSICS & SPACE SCIENCE

---



GLOBAL JOURNAL OF SCIENCE FRONTIER RESEARCH: A  
PHYSICS & SPACE SCIENCE

---

VOLUME 16 ISSUE 6 (VER. 1.0)

© Global Journal of Science  
Frontier Research. 2016.

All rights reserved.

This is a special issue published in version 1.0  
of "Global Journal of Science Frontier  
Research." By Global Journals Inc.

All articles are open access articles distributed  
under "Global Journal of Science Frontier  
Research"

Reading License, which permits restricted use.  
Entire contents are copyright by of "Global  
Journal of Science Frontier Research" unless  
otherwise noted on specific articles.

No part of this publication may be reproduced  
or transmitted in any form or by any means,  
electronic or mechanical, including  
photocopy, recording, or any information  
storage and retrieval system, without written  
permission.

The opinions and statements made in this  
book are those of the authors concerned.  
Ultraculture has not verified and neither  
confirms nor denies any of the foregoing and  
no warranty or fitness is implied.

Engage with the contents herein at your own  
risk.

The use of this journal, and the terms and  
conditions for our providing information, is  
governed by our Disclaimer, Terms and  
Conditions and Privacy Policy given on our  
website [http://globaljournals.us/terms-and-condition/  
menu-1463/](http://globaljournals.us/terms-and-condition/menu-1463/)

By referring / using / reading / any type of  
association / referencing this journal, this  
signifies and you acknowledge that you have  
read them and that you accept and will be  
bound by the terms thereof.

All information, journals, this journal,  
activities undertaken, materials, services and  
our website, terms and conditions, privacy  
policy, and this journal is subject to change  
anytime without any prior notice.

Incorporation No.: 0423089  
License No.: 42125/022010/1186  
Registration No.: 430374  
Import-Export Code: 1109007027  
Employer Identification Number (EIN):  
USA Tax ID: 98-0673427

## Global Journals Inc.

(A Delaware USA Incorporation with "Good Standing"; Reg. Number: 0423089)

Sponsors: *Open Association of Research Society*  
*Open Scientific Standards*

### *Publisher's Headquarters office*

Global Journals® Headquarters  
945th Concord Streets,  
Framingham Massachusetts Pin: 01701,  
United States of America  
USA Toll Free: +001-888-839-7392  
USA Toll Free Fax: +001-888-839-7392

### *Offset Typesetting*

Global Journals Incorporated  
2nd, Lansdowne, Lansdowne Rd., Croydon-Surrey,  
Pin: CR9 2ER, United Kingdom

### *Packaging & Continental Dispatching*

Global Journals  
E-3130 Sudama Nagar, Near Gopur Square,  
Indore, M.P., Pin:452009, India

### *Find a correspondence nodal officer near you*

To find nodal officer of your country, please  
email us at [local@globaljournals.org](mailto:local@globaljournals.org)

### *eContacts*

Press Inquiries: [press@globaljournals.org](mailto:press@globaljournals.org)  
Investor Inquiries: [investors@globaljournals.org](mailto:investors@globaljournals.org)  
Technical Support: [technology@globaljournals.org](mailto:technology@globaljournals.org)  
Media & Releases: [media@globaljournals.org](mailto:media@globaljournals.org)

### *Pricing (Including by Air Parcel Charges):*

#### *For Authors:*

22 USD (B/W) & 50 USD (Color)  
Yearly Subscription (Personal & Institutional):  
200 USD (B/W) & 250 USD (Color)

# GLOBAL JOURNALS CONSTITUTIONAL EDITORIAL BOARD

~INTEGRATED~

## *Dr. Charles A. Rarick*

Ph.D.  
Professor of International Business  
College of Business  
Purdue University Northwest  
Hammond, Indiana USA

## *Dr. Osman Balci, Professor*

Department of Computer Science  
Virginia Tech, Virginia University  
Ph.D. and M.S. Syracuse University, Syracuse, New York  
M.S. and B.S. Bogazici University, Istanbul, Turkey  
Web: [manta.cs.vt.edu/balci](http://manta.cs.vt.edu/balci)

## *Dr. A. Heidari*

Ph.D, D.Sc, Faculty of Chemistry  
California South University (CSU),  
United Stated

## *Dr. Miklas Scholz*

B.Eng. (equiv), PgC, MSc, Ph.D, CWEM, C.Env., CSci,  
C.Eng.  
Nigeria Health, Wellness and Fitness  
University of Lund

## *Dr. Maria Gullo*

Ph.D, Food Science and Technology  
University of Catania  
Department of Agricultural and Food Sciences  
University of Modena and Reggio Emilia, Italy

## *Dr. Qiang Wu*

Ph.D University of Technology, Sydney  
Department of Mathematics,  
Physics and Electrical Engineering  
Northumbria University

## *Dr. Bingyun Li*

Ph.D Fellow, IAES  
Guest Researcher, NIOSH, CDC, Morgantown, WV  
Institute of Nano and Biotechnologies  
West Virginia University, US

## *Dr. Audeh Ahmad Ahmad*

Amman Arab University For Higher Education  
Ph.D, Accounting-Ais  
Faculty of Business Administration  
Alalbyt University, Jordan, Amman

## *Dr. Lucian Baia*

Ph.D Julius-Maximilians University Würzburg, Germany  
Associate professor  
Department of Condensed Matter Physics and  
Advanced Technologies, Babes-Bolyai University,  
Romania

## *Dr. Sahraoui Chaieb*

PhD Physics and Chemical Physics  
M.S. Theoretical Physics  
B.S. Physics, École Normale Supérieure, Paris  
Associate Professor, Bioscience  
King Abdullah University of Science and Technology

## *Dr. Houfa Shen*

Ph.D Manufacturing Engineering,  
Mechanical Engineering, Structural Engineering  
Department of Mechanical Engineering  
Tsinghua University, China

## *Dr. Arshak Poghossian*

Ph.D Solid-State Physics  
Leningrad Electrotechnic Institute, Russia  
Institute of Nano and Biotechnologies  
Aachen University of Applied Sciences, Germany

*Dr. A. Stegou-Sagia*

Ph.D Mechanical Engineering, Environmental  
Engineering School of Mechanical Engineering  
National Technical University of Athens

*Giuseppe A Provenzano*

Irrigation and Water Management, Soil Science,  
Water Science Hydraulic Engineering  
Dept. of Agricultural and Forest Sciences  
Universita di Palermo, Italy

*Dr. Ciprian LĂPUȘAN*

Ph. D in Mechanical Engineering  
Technical University of Cluj-Napoca  
Cluj-Napoca (Romania)

*Dr. Haijian Shi*

Ph.D Civil Engineering Structural Engineering  
Oakland, CA, United States

*Dr. Yogita Bajpai*

Ph.D Senior Aerospace/Mechanical/  
Aeronautical Engineering professional  
M.Sc. Mechanical Engineering  
M.Sc. Aeronautical Engineering  
B.Sc. Vehicle Engineering  
Orange County, California, USA

*Dr. Abdurrahman Arslanyilmaz*

Computer Science & Information Systems Department  
Youngstown State University  
Ph.D., Texas A&M University  
University of Missouri, Columbia  
Gazi University, Turkey  
Web:cis.yzu.edu/~aarslanyilmaz/professional\_web

*Dr. Chao Wang*

Ph.D. in Computational Mechanics  
Rosharon, TX, USA

*Dr. Adel Al Jumaily*

Ph.D Electrical Engineering (AI)  
Faculty of Engineering and IT  
University of Technology, Sydney

*Kitipong Jaojaruek*

B. Eng, M. Eng D. Eng (Energy Technology, Asian  
Institute of Technology).  
Kasetsart University Kamphaeng Saen (KPS) Campus  
Energy Research Laboratory of Mechanical Engineering

*Dr. Mauro Lenzi*

Ph.D, Biological Science, Pisa University, Italy  
Lagoon Ecology and Aquaculture Laboratory  
Orbetello Pesca Lagunare Company

*Dr. Omid Gohardani*

M.Sc. (Computer Science), FICCT, U.S.A.  
Email: yogita@computerresearch.org

*Dr. Yap Yee Jiun*

B.Sc.(Manchester), Ph.D.(Brunel), M.Inst.P.(UK)  
Institute of Mathematical Sciences,  
University of Malaya,  
Kuala Lumpur, Malaysia

*Dr. Thomas Wischgoll*

Computer Science and Engineering,  
Wright State University, Dayton, Ohio  
B.S., M.S., Ph.D.  
(University of Kaiserslautern)  
Web:avida.cs.wright.edu/personal/wischgol/index\_eng.html

*Dr. Baziotis Ioannis*

Ph.D. in Petrology-Geochemistry-Mineralogy  
Lipson, Athens, Greece

*Dr. Xiaohong He*

Professor of International Business  
University of Quinnipiac  
BS, Jilin Institute of Technology; MA, MS, Ph.D,  
(University of Texas-Dallas)  
Web: [quinnipiac.edu/x1606.xml](http://quinnipiac.edu/x1606.xml)

*Dr. Burcin Becerik-Gerber*

University of Southern Californi  
Ph.D in Civil Engineering  
DDes from Harvard University  
M.S. from University of California, Berkeley  
M.S. from Istanbul Technical University  
Web: [i-lab.usc.edu](http://i-lab.usc.edu)

*Dr. Söhnke M. Bartram*

Department of Accounting and Finance  
Lancaster University Management School  
Ph.D. (WHU Koblenz)  
MBA/BBA (University of Saarbrücken)  
Web: [lancs.ac.uk/staff/bartras1/](http://lancs.ac.uk/staff/bartras1/)

*Dr. Söhnke M. Bartram*

Ph.D, (IT) in Faculty of Engg. & Tech.  
Professor & Head,  
Dept. of ISE at NMAM Institute of Technology

*Dr. Balasubramani R*

Department of Accounting and Finance  
Lancaster University Management School  
Ph.D. (WHU Koblenz)  
MBA/BBA (University of Saarbrücken)  
Web: [lancs.ac.uk/staff/bartras1/](http://lancs.ac.uk/staff/bartras1/)

*M. Meguellati*

Department of Electronics,  
University of Batna, Batna 05000, Algeria

*Dr. T. David A. Forbes*

Associate Professor and Range Nutritionist  
Ph.D Edinburgh University - Animal Nutrition  
M.S. Aberdeen University - Animal Nutrition  
B.A. University of Dublin- Zoology.  
Web: [essm.tamu.edu/people-info/faculty/forbes-david](http://essm.tamu.edu/people-info/faculty/forbes-david)

*Dr. Bassey Benjamin Esu*

B.Sc. Marketing; MBA Marketing; Ph.D Marketing  
Lecturer, Department of Marketing, University of Calabar  
Tourism Consultant, Cross River State Tourism  
Development Department  
Co-rdinator , Sustainable Tourism Initiative, Calabar,  
Nigeria

*Dr. Maciej Gućma*

Asistant Professor,  
Maritime University of Szczecin Szczecin, Poland  
Ph.D. Eng. Master Mariner  
Web: [www.mendeley.com/profiles/maciej-gucma/](http://www.mendeley.com/profiles/maciej-gucma/)

*Dr. Maciej Gućma*

Asistant Professor ,  
Maritime Univeristy of Szczecin Szczecin, Poland  
PhD. Eng. Master Mariner  
Web: [www.mendeley.com/profiles/maciej-gucma/](http://www.mendeley.com/profiles/maciej-gucma/)

*Dr. Fotini Labropulu*

Mathematics - Luther College, University of Regina  
Ph.D, M.Sc. in Mathematics  
B.A. (Honours) in Mathematics, University of Windsor  
Web: [luthercollege.edu/Default.aspx](http://luthercollege.edu/Default.aspx)

*Dr. Vesna Stanković Pejnović*

Ph. D. Philosphy , Zagreb, Croatia  
Rusveltova, Skopje, Macedonia

*Dr. Miguel Angel Ariño*

Professor of Decision Sciences  
IESE Business School  
Barcelona, Spain (Universidad de Navarra)  
CEIBS (China Europe International Business School).  
Beijing, Shanghai and Shenzhen  
Ph.D. in Mathematics, University of Barcelona  
BA in Mathematics (Licenciatura)  
University of Barcelona  
Web: [web.iese.edu/MAArino/overview.axd](http://web.iese.edu/MAArino/overview.axd)

*Dr. Philip G. Moscoso*

Technology and Operations Management  
IESE Business School, University of Navarra  
Ph.D in Industrial Engineering and Management,  
ETH Zurich , M.Sc. in Chemical Engineering,  
ETH Zurich Link: Philip G. Moscoso personal webpage

*Dr. Mihaly Mezei*

Associate Professor  
Department of Structural and Chemical Biology  
Mount Sinai School of Medical Center  
Ph.D., Etsv Lornd University, Postdoctoral Training,  
New York University, MSSM home:  
<https://www.mountsinai.org/Find%20A%20Faculty/profile.do?id=0000072500001497192632>  
Lab home - software,  
publications: <https://inka.mssm.edu/~mezei>  
Department: <https://atlas.physbio.mssm.edu>

*Dr. Vivek Dubey (HON.)*

MS (Industrial Engineering),  
MS (Mechanical Engineering)  
University of Wisconsin  
FICCT  
Editor-in-Chief, USA  
[editorusa@globaljournals.org](mailto:editorusa@globaljournals.org)

*Dr. Carlos García Pont*

Associate Professor of Marketing  
IESE Business School, University of Navarra  
Doctor of Philosophy (Management),  
Massachusetts Institute of Technology (MIT)  
Master in Business Administration, IESE,  
University of Navarra  
Degree in Industrial Engineering,  
Universitat Politècnica de Catalunya  
Web: [iese.edu/aplicaciones/faculty/facultyDetail.asp](http://iese.edu/aplicaciones/faculty/facultyDetail.asp)

*Dr. Sanjay Dixit, M.D.*

Director, EP Laboratories, Philadelphia VA Medical Center  
Cardiovascular Medicine - Cardiac Arrhythmia  
University of Penn School of Medicine  
Web: [pennmedicine.org/wagform/MainPage.aspx?](http://pennmedicine.org/wagform/MainPage.aspx?)

*Dr. Pina C. Sanelli*

Associate Professor of Radiology  
Associate Professor of Public Health  
Weill Cornell Medical College  
Associate Attending Radiologist  
NewYork-Presbyterian Hospital  
MRI, MRA, CT, and CTA  
Neuroradiology and Diagnostic Radiology  
M.D., State University of New York at Buffalo,  
School of Medicine and Biomedical Sciences  
Web: [weillcornell.org/pinasanelli/](http://weillcornell.org/pinasanelli/)

*Er. Suyog Dixit*

(M.Tech), BE (HONS. in CSE), FICCT  
SAP Certified Consultant  
CEO at IOSRD, GAOR OSS  
Technical Dean, Global Journals Inc.(US)  
Website: [www.suyogdixit.com](http://www.suyogdixit.com)  
Email: [suyog@suyogdixit.com](mailto:suyog@suyogdixit.com),  
[deanind@globaljournals.org](mailto:deanind@globaljournals.org)



*Er. Pritesh Rajvaidya*

Computer Science Department  
California State University  
BE (Computer Science), FICCT  
Technical Dean, USA  
Email: [pritesh@computerresearch.org](mailto:pritesh@computerresearch.org),  
[deanusa@globaljournals.org](mailto:deanusa@globaljournals.org)

*Dr. Apostolos Ch. Zarros*

DM, Degree (Ptychio) holder in Medicine,  
National and Kapodistrian University of Athens  
MRes, Master of Research in Molecular Functions in  
Disease,  
University of Glasgow  
FRNS, Fellow, Royal Numismatic Society  
Member, European Society for Neurochemistry  
Member, Royal Institute of Philosophy  
Scotland, United Kingdom

*Dr. Han-Xiang Deng*

MD., Ph.D  
Associate Professor and Research Department  
Division of Neuromuscular Medicine  
Davee Department of Neurology and Clinical  
Neurosciences  
Northwestern University Feinberg School of Medicine  
Web: [neurology.northwestern.edu/faculty/deng.html](http://neurology.northwestern.edu/faculty/deng.html)

*Dr. Roberto Sanchez*

Associate Professor  
Department of Structural and Chemical Biology  
Mount Sinai School of Medicine  
Ph.D., The Rockefeller University  
Web: [mountsinai.org/](http://mountsinai.org/)

*Jixin Zhong*

Department of Medicine,  
Affiliated Hospital of Guangdong Medical College,  
Zhanjiang, China Davis Heart and Lung Research Institute,  
The Ohio State University, Columbus, OH 43210, USA

*Dr. Wen-Yih Sun*

Professor of Earth and Atmospheric Sciences  
Purdue University, Director  
National Center for Typhoon and Flooding Research,  
Taiwan  
University Chair Professor  
Department of Atmospheric Sciences,  
National Central University, Chung-Li, Taiwan  
University Chair Professor  
Institute of Environmental Engineering,  
National Chiao Tung University, Hsin-chu, Taiwan.  
Ph.D., MS The University of Chicago, Geophysical Sciences  
BS National Taiwan University, Atmospheric Sciences  
Web: [event.nchc.org.tw/2009](http://event.nchc.org.tw/2009)

*Dr. Michael R. Rudnick*

M.D., FACP  
Associate Professor of Medicine  
Chief, Renal Electrolyte and Hypertension Division (PMC)  
Penn Medicine, University of Pennsylvania  
Presbyterian Medical Center, Philadelphia  
Nephrology and Internal Medicine  
Certified by the American Board of Internal Medicine  
Web: [uhs.upenn.edu/](http://uhs.upenn.edu/)

*Dr. Aziz M. Barbar, Ph.D.*

IEEE Senior Member  
Chairperson, Department of Computer Science  
AUST - American University of Science & Technology  
Alfred Naccash Avenue - Ashrafieh

*Dr. Minghua He*

Department of Civil Engineering  
Tsinghua University  
Beijing, 100084, China

*Anis Bey*

Dept. of Comput. Sci.,  
Badji Mokhtar-Annaba Univ.,  
Annaba, Algeria

*Chutisant Kerdvibulvech*

Dept. of Inf.& Commun. Technol.,  
Rangsit University, Pathum Thani, Thailand  
Chulalongkorn University, Thailand  
Keio University, Tokyo, Japan

*Dr. Wael Abdullah*

Elhelece Lecturer of Chemistry,  
Faculty of science, Gazan Univeristy,  
KSA. Ph. D. in Inorganic Chemistry,  
Faculty of Science, Tanta University, Egypt

*Yaping Ren*

School of Statistics and Mathematics  
Yunnan University of Finance and Economics  
Kunming 650221, China

*Ye Tian*

The Pennsylvania State University  
121 Electrical Engineering East  
University Park, PA 16802, USA

*Dr. Diego González-Aguilera*

Ph.D. Dep. Cartographic and Land Engineering,  
University of Salamanca, Ávila, Spain

*Dr. Maciej Gućma*

PhD. Eng. Master Mariner  
Warsaw University of Technology  
Maritime University of Szczecin  
Waly Chrobrego 1/2 70-500 Szczecin, Poland

*Dr. Tao Yang*

Ph.D, Ohio State University  
M.S. Kansas State University  
B.E. Zhejiang University

*Dr. Feng Feng*

Boston University  
Microbiology, 72 East Concord Street R702  
Duke University  
United States of America

*Shengbing Deng*

Departamento de Ingeniería Matemática,  
Universidad de Chile.  
Facultad de Ciencias Físicas y Matemáticas.  
Blanco Encalada 2120, piso 4.  
Casilla 170-3. Correo 3. - Santiago, Chile

*Claudio Cuevas*

Department of Mathematics  
Universidade Federal de Pernambuco  
Recife PE Brazil

*Dr. Alis Puteh*

Ph.D. (Edu.Policy) UUM  
Sintok, Kedah, Malaysia  
M.Ed (Curr. & Inst.), University of Houston, USA

*Dr. R.K. Dixit(HON.)*

M.Sc., Ph.D., FICCT Chief Author, India  
Email: [authorind@globaljournals.org](mailto:authorind@globaljournals.org)

*Dr. Dodi Irawanto*

PhD, M.Com, B.Econ Hons.  
Department of Management,  
Faculty of Economics and Business, Brawijaya University  
Malang, Indonesia

*Ivona Vrdoljak Raguz*

University of Dubrovnik, Head,  
Department of Economics and Business Economics,  
Croatia

*Dr. Prof Adrian Armstrong*

BSc Geography, LSE, 1970  
PhD Geography (Geomorphology)  
Kings College London 1980  
Ordained Priest, Church of England 1988  
Taunton, Somerset, United Kingdom

*Thierry FEUILLET*

Géolittomer – LETG UMR 6554 CNRS  
(Université de Nantes)  
Institut de Géographie et d'Aménagement  
Régional de l'Université de Nantes.  
Chemin de la Censive du Tertre – BP, Rodez

*Dr. Yongbing Jiao*

Ph.D. of Marketing  
School of Economics & Management  
Ningbo University of Technology  
Zhejiang Province, P. R. China

*Cosimo Magazzino*

Roma Tre University  
Rome, 00145, Italy

*Dr. Christos Kalialakis*

Ph.D., Electrical and Electronic Engineering,  
University of Birmingham,  
UKM.Sc., Telecommunications, Greece B.Sc, Physics,  
Aristotle University of Thessaloniki, Greece

*Dr. Alex W. Dawotola*

Hydraulic Engineering Section,  
Delft University of Technology,  
Stevinweg, Delft, Netherlands

*Dr. Luisa dall'Acqua*

PhD in Sociology (Decisional Risk sector),  
Master MU2, College Teacher in Philosophy (Italy),  
Edu-Research Group, Zürich/Lugano

*Xianghong Qi*

University of Tennessee  
Oak Ridge National Laboratory  
Center for Molecular Biophysics  
Oak Ridge National Laboratory  
Knoxville, TN 37922, United States

*Gerard G. Dumancas*

Postdoctoral Research Fellow,  
Arthritis and Clinical Immunology Research Program,  
Oklahoma Medical Research Foundation  
Oklahoma City, OK  
United States

*Vladimir Burtman*

Research Scientist  
The University of Utah, Geophysics  
Frederick Albert Sutton Building, 115 S 1460 E Room 383  
Salt Lake City, UT 84112, USA

*Jalal Kafashan*

Mechanical Engineering, Division of Mechatronics  
KU Leuven, BELGIUM

*Zhibin Lin*

Center for Infrastructure Engineering Studies  
Missouri University of Science and Technology  
ERL, 500 W. 16th St. Rolla,  
Missouri 65409, USA

*Dr. Lzzet Yavuz*

MSc, PhD, D Ped Dent.  
Associate Professor,  
Pediatric Dentistry Faculty of Dentistry,  
University of Dicle, Diyarbakir, Turkey

*Prof. Dr. Eman M. Gouda*

Biochemistry Department,  
Faculty of Veterinary Medicine, Cairo University,  
Giza, Egypt

*Della Ata*

BS in Biological Sciences  
MA in Regional Economics  
Hospital Pharmacy  
Pharmacy Technician Educator

*Dr. Muhammad Hassan Raza, PhD*

Engineering Mathematics  
Internetworking Engineering, Dalhousie University,  
Canada

*Dr. Shaoping Xiao*

BS, MS, Ph.D Mechanical Engineering,  
Northwestern University  
The University of Iowa  
Department of Mechanical and Industrial Engineering  
Center for Computer-Aided Design

*Dr. Asunción López-Varela*

BA, MA (Hons), Ph.D (Hons)  
Facultad de Filología.  
Universidad Complutense Madrid  
29040 Madrid, Spain

*Dr. Bondage Devanand Dhondiram*

Ph.D  
No. 8, Alley 2, Lane 9, Hongdao station,  
Xizhi district, New Taipei city 221, Taiwan (ROC)

*Dr. Latifa Oubedda*

National School of Applied Sciences,  
University Ibn Zohr, Agadir, Morocco  
Lotissement Elkhier N°66  
Bettana Salé Maroc

*Dr. Hai-Linh Tran*

PhD in Biological Engineering  
Department of Biological Engineering  
College of Engineering Inha University, Incheon, Korea

*Dr. Shun-Chung Lee*

Department of Resources Engineering,  
National Cheng Kung University, Taiwan

## CONTENTS OF THE ISSUE

---

- i. Copyright Notice
- ii. Editorial Board Members
- iii. Chief Author and Dean
- iv. Contents of the Issue
  1. Nature of Some Conceptual Problems in Geometry and in the Particle Dynamics. *1-19*
  2. Application of Electrical Resistivity Method in Designing a Structural Model for a Proposed Filling Station Site, Akure, Southwestern Nigeria. *21-34*
  3. Bianchi Type VI Cosmological Model with Quadratic form of Time Dependent  $\Lambda$  Term in General Relativity. *35-47*
  4. Effect of Radiation on Thermal Explosion Characteristics of Non-Newtonian Fluids. *49-53*
  5. Cutting-off Einstein's Special Relativity Theory by Occam's Sickle (How the Mountain (Large Hadron Collider) has Brought Forth a Mouse) Mamaev A. V., Candidate of Engineering Sciences, Bureau Chief JSC "Lianozovo Electromechanical Plant R&P Corp.", Russia. *55-67*
  6. Fluids through Inclined Granular Media. *69-74*
  7. Tokamak, Accelerators, Colliders and Maxwell's Electrodynamics. *75-83*
  8. Management Photoluminescence and Electrical Properties of the Double-Barrier Structure based on Silicon Gamma - Rays and Radiation Defect. *85-88*
  9. Physics and Philosophy of Wave Reference Frames in A Retrospective of 20-th Century Findings and Illusions. *89-112*
- v. Fellows
- vi. Auxiliary Memberships
- vii. Process of Submission of Research Paper
- viii. Preferred Author Guidelines
- ix. Index



## Nature of Some Conceptual Problems in Geometry and in the Particle Dynamics

By Yuri A. Rylov

*Russian Academy of Sciences*

**Abstract-** The particle dynamics conception (mathematical formalism) changes rather rare in the process of the particle dynamics development. It connected with associative delusions in the existing dynamics conception and with the logical reloading which is a means of the associative delusion overcoming. Influence of associative delusions (AD) onto development of physics and mathematics is investigated. The associative delusion (AD) means a mistake, appearing from incorrect associations, when a property of one object is attributed to another one. Examples of most ancient delusions are: (1) connection of the gravitation field direction with a preferred direction in space (instead of the direction to the Earth center), that had lead to the antipode paradox, (2) statement that the Earth (not the Sun) is a center of the planetary system, that had lead to the Ptolemaic doctrine. Now these ADs have been overcome.

**Keywords:** *logical reloading, associative mistakes, structural approach, foundation of quantum theory, multivariant geometry, physics geomerization, investiga- tion styles.*

**GJSFR-A Classification:** FOR Code: 240503



*Strictly as per the compliance and regulations of :*



# Nature of Some Conceptual Problems in Geometry and in the Particle Dynamics

Yuri A. Rylov

**Abstract-** The particle dynamics conception (mathematical formalism) changes rather rare in the process of the particle dynamics development. It connected with associative delusions in the existing dynamics conception and with the logical reloading which is a means of the associative delusion overcoming. Influence of associative delusions (AD) onto development of physics and mathematics is investigated. The associative delusion (AD) means a mistake, appearing from incorrect associations, when a property of one object is attributed to another one. Examples of most ancient delusions are: (1) connection of the gravitation field direction with a preferred direction in space (instead of the direction to the Earth center), that had lead to the antipode paradox, (2) statement that the Earth (not the Sun) is a center of the planetary system, that had lead to the Ptolemaic doctrine. Now these ADs have been overcome. In the paper one considers four modern and not yet got over ADs, whose corollaries are false space-time geometry in the microcosm and most of problems and difficulties of the quantum field theory (QFT). One shows that ADs have a series of interesting properties: (1) ADs appear to be long-living delusions, because they are compensated partly by means of introduction of compensating (Ptolemaic) conceptions, (2) ADs influence on scientific investigations, generating a special pragmatic style (P-style) of investigations resembling the experimental trial and error method, (3) ADs act on investigations directly and via P-style, ADs direct the science development into a blind alley. One considers concrete properties of modern ADs and the methods of their overcoming. From viewpoint of application the paper is an analysis of mistakes, made in the quantum theory development. One analyses reasons of these mistakes and suggests methods of their correction.

**Keywords:** *logical reloading, associative mistakes, structural approach, foundation of quantum theory, multivariant geometry, physics geomerization, investigation styles.*

## I. INTRODUCTION

The logical reloading is a new logical operation [1]. It used in the classical particle dynamics and in the proper Euclidean geometry. In the classical particle dynamics the logical reloading changes the basic object of dynamics. A single deterministic particles  $S_d$  is replaced by a statistical ensemble  $\mathcal{E}[S_d]$  of particles  $S_d$ . As a result mathematical formalism of particle dynamics changes. Dynamics of discrete dynamic systems transforms to dynamics of continuous

medium. As a result of the logical reloading the new formalism of the deterministic particle dynamics enables to describe dynamics of stochastic particles  $S_{st}$ , because the statistical ensemble  $\mathcal{E}[S_{st}]$  is a dynamic system, even if the statistical ensemble consists of stochastic particles  $S_{st}$ . Motion of a stochastic particle  $S_{st}$  cannot be described exactly. One can describe only mean motion of the stochastic particle. For instance, motion of a gas volume describes a mean motion of the gas molecules, whose exact motion is stochastic.

A change of the particle dynamics formalism is a very rare phenomenon. Last time it was changed in the beginning of the twentieth century, when the classical dynamics has been replaced by the quantum mechanics (the ordinary dynamics variables were replaced by matrix dynamic variables). The logical reloading conserves the classical dynamics in the sense that it does not introduce new fundamental conceptions such as wave function. However, it transforms the dynamics of discrete dynamic systems to a classical dynamics of continuous medium and explains the wave function as a derivative concept. As a result the quantum mechanics appears to be founded as a classical dynamics of stochastic particles (of a continuous medium).

Contemporary researchers do not work with transformation of dynamics conceptions and transformation of the dynamics formalism. They work only with different Lagrangians in the framework of the same formalism (classical or quantum conception). Correctness of a Lagrangian choice can be tested by experiment. One solves dynamic equations generated by a chosen Lagrangian. The obtained calculated results can be tested experimentally. If the calculated results are true, one concludes, that the Lagrangian is taken correctly.

Correctness of a change of mathematical formalism of dynamics cannot be tested by one experimental test. The experimental test is to be made for all Lagrangians. If the result, calculated for a concrete Lagrangian, does not coincide with experiment, one cannot decide what is a reason of discrepancy: a choice of the new mathematical formalism or a choice of the Lagrangian. Working with the new mathematical formalism, one is forced to use another criterion of correctness, than coincidence with experiment. One is forced to look for defects, or

**Author:** *Institute for Problems in Mechanics, Russian Academy of Sciences, 101-1, Vernadskii Ave., Moscow, 117526, Russia.  
e-mail: rylov@ipmnet.ru*

mistakes in the existing mathematical formalism of dynamics and to correct this mistake. Such an approach facilitates a choice of a new conception of dynamics (new mathematical formalism).

Thus, the investigation strategy in construction of a new conception of the particle dynamics (new mathematical formalism of dynamic) looks as follows. One looks for defects (mistakes) in the existing conception of dynamics and corrects the discovered mistakes. A search of mistakes in the existing dynamic conception is a very difficult problem. Most researchers believe that there are no mistakes in the existing conception of dynamics. Nevertheless a mistake has been found. It consists in the fact that the dynamic equations for relativistic particles are relativistic, but the particle state is nonrelativistic [2, 3]. Correction of this mistake led to the logical reloading in classical dynamics of stochastic particles. Mistake in the definition of the relativistic particle state is of no importance in the dynamics of deterministic relativistic particles, but it is important in the dynamics of stochastic relativistic particles, because one uses a statistical ensemble in this definition. The statistical ensemble is essentially a calculation of the particle states. In this case a true definition of the particle state is important.

A difficulty in perception of the quantum mechanics foundation is connected also with the fact, that the transformation from dynamical equations for the statistical ensemble to the Schrödinger (or Klein-Gordon) equation contains a partial integration, which leads to appearance of three arbitrary functions  $g^\alpha(\xi)$ ,  $\alpha = 1, 2, 3$ . In the Schrödinger equation the wave function is constructed of these functions  $g^\alpha(\xi)$ . A transition from dynamic equations for the continuous medium to the Schrödinger equation is impossible without this integration.

Logical reloading in the Euclidean geometry leads to a monistic conception of a geometry, which is described completely in terms of a unique quantity: metric (world function). The logical reloading is also connected with some correction of geometric representations. In particular, after the logical reloading one refuses from the triangle axiom, which appears to be a special property of the proper Euclidean geometry. The logical reloading in the Euclidean geometry leads to a change of the mathematical formalism of the geometry. The obtained mathematical formalism is more general. It can be used in the case, when the triangle axiom does not take place.

Mistakes eliminated by the logical reloading are associative mistakes (associative delusions), which appear, when properties of one object are ascribed to another object. In the conventional formalism of a geometry the property of one-dimensionality of straight line segment (the triangle axiom), which is a property of the proper Euclidean geometry, is ascribed to any

geometry at all. This constraint removes from consideration many space-time geometries, in particular, discrete geometries.

In practice the logical reloading in geometry and in classical dynamics were obtained as a result of discovery of associative delusions. I believe that this investigation strategy is most effective in the case, when the theoretical physics is in the blind alley. In this case a search of effective Lagrangians, basing on experimental data, is not effective, because in this case one works in the framework of existing conception. Changing a Lagrangian one obtain a description of a single physical phenomenon, whereas one needs to explain a wide class of physical phenomena. One needs to change a conception (existing mathematical formalism). This change can be carried out only by a change of conception. To change the existing conception one needs to search of associative delusions in the existing conception and to use the logical reloading. It is a very difficult problem, and one needs to know properties of the associative delusions.

The present paper is devoted to a study of associative delusions, their role in the natural science development and to problems of their overcoming.

## II. THE ASSOCIATIVE DELUSION. WHAT IS IT?

The associative delusion means such a situation, when associative properties of human thinking actuate incorrectly, and the natural phenomenon is attributed by properties alien to it. Usually one physical phenomenon is attributed by properties of other physical phenomenon, or properties of the physical phenomenon description are attributed to the physical phenomenon in itself. Let us illustrate this in a simple example, which is perceived now as a grotesque.

It is known that ancient Egyptians believed that all rivers flow towards the North. This delusion seems now to be nonsense. But many years ago it had weighty foundation. The ancient Egyptians lived on a vast flat plane and knew only one river the Nile, which flowed exactly towards the North and had no tributaries on the Egyptian territory. The North direction was a preferred direction for ancient Egyptians who observed motion of heavenly bodies regularly. It was direction toward the fixed North star. They did not connect direction of the river flow with the plane slope, as we do now. They connected the direction of the river flow with the preferred spatial direction towards the North. We are interested now what kind of mistake was made by ancient Egyptians, believing that all rivers flow towards the North, and how could they to overcome their delusion.

Their delusion was not a logical mistake, because the logic has no relation to this mistake. The delusion was connected with associative property of human thinking, when the property  $P$  is attributed to the



object  $O$  on the basis that in all known cases the property  $P$  accompanies the object  $O$ . Such an association may be correct or not. If it is erroneous, as in the given case, it is very difficult to discover the mistake logically. But it can be discovered experimentally.

However, if an associative delusion (AD) relates to a notion, an experimental test of the statement is impossible. In this case a discovery of the associative delusion is very difficult. For instance, the statement:  $(St_1)$  *A straight line is a one-dimensional set in any geometry* may be an associative delusion (AD), because we know only the Euclidean geometry and the Riemannian geometry, where the straight line (or geodesic) is a one-dimensional set. The statement  $St_1$  is connected with the other statement:  $(St_2)$  *Any geometry is a logical construction, or any geometry is axiomatizable*. The last statement  $St_2$  can be formulated in the form:  $(St_3)$  *Nonaxiomatizable geometries do not exist*.

The mathematical community believes, that there exist no nonaxiomatizable geometries, because one is not able to construct nonaxiomatizable geometries. Geometry has been arisen many years ago as a science on a shape of geometrical objects and on their mutual disposition in space. It was the proper Euclidean geometry  $\mathcal{G}_E$ . Any geometrical object in  $\mathcal{G}_E$  can be constructed of blocks. Blocks are segments of straight line. Any geometrical object  $O$  can be filled by a set  $S$  of straight line segments  $L$  in such a way, that any point  $\forall P \in O$  belongs to one and only one segment  $L \in S$ . Segments  $L$  have no common points. This property of  $\mathcal{G}_E$  can be used for construction of any geometrical object  $O$  of the Euclidean geometry  $\mathcal{G}_E$ . Properties of the straight line segment can be formulated as some statements  $S_1$ . The rules of displacement of the straight line segments can be also formulated as some statements  $S_2$ . Using these statements  $S_1$  and  $S_2$ , one can formulate the rules for construction of any geometrical object in  $\mathcal{G}_E$ . Considering  $St = S_1 \wedge S_2$  as basic statements (axioms) of  $\mathcal{G}_E$ , one can obtain the rules of any geometrical object construction as a logical corollary of  $St$  and of definition of the geometric object. These rules can be formulated as some statements. The set of these statements forms the proper Euclidean geometry  $\mathcal{G}_E$ .

Such a form of the Euclidean geometry  $\mathcal{G}_E$  presentation can be qualified as the axiomatic conception of  $\mathcal{G}_E$ . Connection of the logic with the Euclidean geometry was clear for contemporaries of Euclid. But now this connection is lost. One considers the logical construction of the proper Euclidean geometry as an evident thing.

The Euclidean geometry  $\mathcal{G}_E$  is considered formally as a logical construction founded on the set  $St$  of Euclidean axioms. Usually one does not consider the reasons, why the logic is connected with a geometry and why the Euclidean geometry  $\mathcal{G}_E$  is a logical

construction. One believes, that any logical construction, containing axioms about properties of the simplest geometrical objects such as the straight line, describes some geometry  $\mathcal{G}$ , which may differ from  $\mathcal{G}_E$ . The symplectic geometry has no relation to properties of geometrical objects. Nevertheless, it is treated as some kind of a geometry, because it is a logical construction, which is close to the Euclidean geometry  $\mathcal{G}_E$ .

However, geometrical objects may be constructed as a result of a deformation of the Euclidean geometry  $\mathcal{G}_E$  into a generalized geometry  $\mathcal{G}$ . In this case a one-dimensional straight line segment  $L_E \subset \mathcal{G}_E$  may be deformed into a hollow tube  $L \subset \mathcal{G}$ , which cannot be used as a constructing block. In this case the generalized geometry  $\mathcal{G}$  obtained from  $\mathcal{G}_E$  as a result of a deformation will not be an axiomatizable geometry. Thus, the statements  $St_2$  and  $St_3$  appear to be associative delusions, if the space-time geometry (for instance, a discrete space-time geometry) is constructed by means of the deformation principle [4, 5, 1].

If the established association between the object and its property is erroneous, one can speak on associative delusion or on associative prejudice. The usual method of the associative delusions overcoming is a consideration of a wider set of phenomena, where the established association between the property  $P$  and the object  $O$  may appear to be violated, and the associative delusion may be discovered.

In this paper the associative delusions in natural sciences, mainly in physics are discussed. The associative delusions (AD) are very stable. They are overcome very difficultly, because they cannot be disproved logically. But there is an additional complication. The usual mistake is overcome easily by the scientific community, as soon as it has been overcome by one of its members. The corresponding article is published, and the scientific community takes it into account, and the mistake is considered to be corrected.

A different situation arises with the associative delusions (AD). Discovery of the associative delusion (AD), and publication of corresponding article do not lead to acknowledgment of AD as a delusion or mistake. The scientific community continue to insist on the statement, that the considered in the article AD is not a mistake in reality, and that the author of this paper makes himself a mistake. A long controversy arises. Sometimes it leads to a conflict, as in the case of conflict between the Ptolemaic doctrine and that of Copernicus. Finally, the truth celebrates victory, but the way to this victory appears to be long and difficult.

Apparently, the reason of the AD stability lies in obviousness and habitualness of those statements, which appear to be associative delusions afterwards. On the ground of these statements one constructs scientific conceptions, which agree with experimental

data and observations. Declaring these habitual statements to be a delusions, one destroys existing scientific conceptions and tries to construct new conceptions. It is very difficult always for the scientific community.

In the science history a series of associative delusions is known. Let us list them in the chronological order.

AD.1. The antipodes paradox, generated by that the gravitational field direction is connected with a preferred direction in the space, but not with the direction towards the Earth center.

AD.2. The Ptolemaic doctrine in the celestial mechanics, where the property of being the "universe" center was attributed to the Earth, whereas the Sun is such a center.

AD.3. Prejudices against the Riemannian geometry in the second half of the XIX century are connected with that the Cartesian coordinate system was considered to be an attribute of any geometry, whereas it was only a method of the Euclidean geometry description.

AD.4. Impossibility of employment of the pure metrical conception of geometry, connected with the associative delusion, that the concept of the one-dimensional curve is considered to be a fundamental concept of any geometry, whereas the one dimensional curve is only a geometrical object, used in the Euclidean and the Riemannian geometry.

AD.5. The stochastic particles dynamics, when the basic object of dynamics is a single stochastic particle. Any statistical description is produced in terms of the probability theory, and the probability concept is considered as a fundamental concept of any statistical description.

AD.6. Identification of individual particle  $\mathcal{S}$  with the statistically averaged particle  $\langle \mathcal{S} \rangle$ , used at the conventional interpretation of quantum mechanics. Such an identification is a kind of associative delusion, when the individual particle  $\mathcal{S}$  properties are attributed to the statistically averaged particle  $\langle \mathcal{S} \rangle$  and vice versa. The Schrödinger cat paradox and some other quantum mechanics paradoxes, connected with the wave function reduction, are corollaries of this identification.

AD.7. The forced identification of energy and Hamiltonian, used in relativistic quantum field theory (QFT), is also an associative delusion. As any associative delusion this identification is connected with attributing properties of one object to another one. Coincidence of energy and Hamiltonian for a free nonrelativistic particle is considered to be a fundamental property of any particle, whereas this property takes place only in the case, when there is no pair production.

The first three of the seven listed delusions (AD.1 .AD.3) had been overcome to the beginning of XX century, though a detailed analysis of these overcoming

is, maybe, absent in the literature. As to AD.4 .AD.7, the scientific community is yet destined to overcome them. Besides, these ADs exist simultaneously, and the order of their listing corresponds basically to their importance rather, than to chronology.

The purely metric conception of geometry (CG), where all information on geometry is given by means of a distance between two space points, is the most general conception of geometry (CG). It generates the most complete list of geometries, suitable for the space-time description. AD.4 discriminates the purely metric CG. As a result instead of it one uses Riemannian CG, generating incomplete list of possible geometries. The true space-time geometry is absent in this list, and we are doomed to use the Minkowski geometry for the space-time description. The Minkowski geometry is incorrect geometry for small space-time scales, i.e. in the microcosm. In the true space-time geometry the microparticle motion is primordially stochastic, and the properties of the geometry are an origin of this stochasticity. In the Minkowski geometry the motion of any particle, described by the timelike world line, is deterministic, and incorrectness of the Minkowski geometry lies in this fact.

AD.5 leads to impossibility of a construction of a consecutive statistical description of the stochastically moving microparticles (electrons, positrons, etc.), although it is doubtless that quantum mechanics, describing the regular component of this motion, is a statistical theory. AD.4 and AD.5 establish such a situation, when one is forced to use a series of additional hypotheses (quantum mechanics principles) for a correct description of observed quantum phenomena. It reminds situation, when Ptolemy used a series of additional constructions (epicycles, differents) for explanation of observed motion of heavenly bodies. They were needed for compensation of AD.2.

Overcoming of AD.5 admits one to eliminate the quantum mechanics principles and to construct the quantum phenomena theory as a consecutive classical dynamics of stochastic particle. At such a description the microparticle stochasticity has a geometric origin, i.e. it is generated by the space-time geometry. The consecutive classical description of the stochastic particles appears as a result of a change of the basic object of dynamics (*a single particle is replaced by a statistical ensemble*). The statistical ensemble is a *dynamic system* even in the case, when it consists of stochastic particles.

Overcoming of AD.5 and AD.4 admits one to use structural approach in the theory of elementary particles [1, 6], when one investigates the arrangement of elementary particles. The structural approach differs from the conventional empirical approach, which cannot investigate the arrangement of elementary particles. It

can only ascribe some quantum numbers to any elementary particle. The difference between the structural approach and the empirical approach can be seen in the example of the chemical elements investigations. The structural approach (atomic physics) investigates the atom arrangement (nucleus, electron envelope), whereas the empirical approach (chemistry) ascribes some properties (atomic weight, valency, etc.) to any chemical element without penetration into atom arrangement. The mathematical formalism appears to be more developed in the case of the structural approach.

AD.6 has not such a global character as AD.4 and AD.5. It concerns mainly the interpretation of the concept of a measurement in quantum mechanics.

AD.7 has not the global character also. It acts only in the framework of the relativistic quantum field theory (QFT). QFT in itself reminds the Ptolemaic conception, i.e. a conception, which uses additional hypotheses (quantum mechanics principles), compensating incorrect choice of the space-time model. AD.7 (identification of energy and Hamiltonian  $E = H$ ) generates a series of difficulties in QFT (non-stationary vacuum, necessity of the perturbation theory and some other). In fact, there is no necessity of the energy-Hamiltonian identification  $E = H$ . The secondary quantization can be carried out without imposing this constraint [7, 8]. The condition  $E = H$  appears to be inconsistent with dynamic equations. Imposition of this constraint makes QFT to be inconsistent. On one hand, such an inconsistency leads to above mentioned difficulties, but on the other hand, such an inconsistency admits one to explain the pair production effect, because any inconsistent theory admits one to explain all what one wants. One needs only to show sufficient ingenuity. On one hand, elimination of the constraint  $E = H$  leads to a theory which is consequent in the framework of quantum theory and free from the above mentioned difficulties, but on the other hand, it leads to that the theory ceases to describe the pair production effect. This deplorable fact means only, that the undertaken attempt of the FTP construction on the basis of unification of the relativity principles with those of quantum mechanics failed, and one should search for alternative conception.

Let us take into account that the quantum mechanics is a compensating (Ptolemaic) conception, i.e. just as the quantum mechanics principles have been invented for compensation of AD.4 and of AD.5 in the same way, as the Ptolemaic epicycles have been invented for compensation of AD.2. Then an attempt of unification of quantum mechanics principles with the relativity principles is as useless, as an attempt of introduction of Ptolemaic epicycles in Newtonian mechanics.

Apparently, the conception, appeared after overcoming of AD.4 and AD.5, is a reasonable

alternative to QFT. Such a conception is consistently relativistic and quantum (in the sense that it contains the quantum constant  $\hbar$ , contained explicitly in the space-time metric). It does not contain the quantum mechanics principles, and one does not need to unite them with the relativity principles. We shall refer to this conception as the model conception of quantum phenomena, distinguishing it from conventional quantum mechanics, which will be referred to as axiomatic conception of quantum phenomena. The difference between the axiomatic conception and the model conception is much as the difference between the thermodynamics and the statistical physics. The thermodynamics may be qualified as the axiomatic conception of thermal phenomena, whereas the statistical physics may be qualified as the model conception of thermal phenomena. The transition from the axiomatic conception to the model one was carried out after a construction of the "calorific fluid" model (chaotic motion of molecules), and the thermodynamics axioms, describing properties of the fundamental thermodynamical object – "calorific fluid". Concept of "calorific fluid" is not used usually in the statistical physics, but if it is introduced, its properties are determined from its model (chaotic molecular motion).

Similar situation takes place in the interrelations between the axiomatic and model conceptions of quantum phenomena. In the axiomatic conception there is a fundamental object, called the wave function. Its properties are determined by the quantum mechanics principles. The wave function is that object, which distinguishes the quantum mechanics from the classical one, where the wave function is absent. In the model conception one constructs a "model of the wave function" [9]. Thereafter the wave function properties are obtained from this model, and one does not need the quantum mechanics principles. Axiomatic and model conceptions lead to the same result in the nonrelativistic case, but in the relativistic case the results are different, in general. For instance, application of the model conception to investigation of the dynamic system  $\mathcal{S}_D$ , described by the Dirac equation, leads to another result [10, 11, 12], than investigation, produced by conventional methods in the framework of the axiomatic conception. In the first case the classical analog of the Dirac particle  $\mathcal{S}_D$  is a relativistic rotator, consisting of two charged particles, rotating around their common center of mass. In the second case the classical analog is a pointlike particle, having spin and magnetic moment. An existence of the associative delusion does not permit one to construct a rigorous scientific conception. The constructed building appears to be a compensating (Ptolemaic) conception, where an incorrect statement is compensated by means of additional suppositions. In general, the Ptolemaic conception is not true. But there are such fields of its application, where its employment leads to correct

results, which agree with observations and experimental data. For instance, in the framework of the Ptolemaic doctrine one can choose such epicycles and differentials for any planet, that one can calculate its motion in a sufficient long time so, that predictions agree with observations. But there is a class of the celestial mechanics problems, which could not be solved in the framework of the Ptolemaic doctrine. For instance, in the framework of this doctrine one cannot solve such a problem: when and with what velocity should one throw a stone from the Earth's surface, in order that it could drop on the Moon. In the framework of the Ptolemaic doctrine one cannot discover the gravitation law and construct the Newtonian mechanics. The associative delusion, embedded in the ground of the Ptolemaic doctrine and disguised by means of compensating hypotheses, hindered the progress of celestial mechanics. As far as in that time the celestial mechanics was the only exact natural science, AD hindered the normal development of natural sciences at all. The development of natural sciences went to blind alley. After overcoming of AD.2 the natural sciences development was accelerated strongly.

The same situation takes place with the quantum mechanics. Although at the first acquaintance the quantum mechanics seems to be a disordered collection of rules for calculation of mathematical expectations, nevertheless, in the nonrelativistic case an employment of these rules leads to results which agree with experiments. Accepting the quantum mechanical principles, the nonrelativistic quantum mechanics as a whole is a consistent conception, which describes excellently a wide class of physical phenomena. But at the transition to the field of relativistic phenomena (pair production, elementary particles theory) the quantum principles ceases to be sufficient. One is forced to introduce new suppositions. The further the quantum theory advances in the field of relativistic phenomena, the more new suppositions are to be introduced for descriptions of observed phenomena. This is an indirect indication, that the conventional way of the quantum theory development comes to a blind alley.

Investigation of possible methods of the associative delusions overcoming is a subject of this paper. On one hand, overcoming of any special associative delusion needs a knowledge of the subject of investigation and a professional approach to the investigation of the phenomenon. On the other hand, the Ptolemaic conceptions have some common properties, and a work with them has some specific character, which should be known, if we want to overcome corresponding ADs effectively.

First, it is very difficult to discover the associative delusion. Indirect indications of AD are an increasing complexity of the theory and a necessity of new additional suppositions. These indications show

that the associative delusion does exist, but they do not permit one to determine, what is this AD.

Second, the work with Ptolemaic conceptions, i.e. with conceptions, containing AD, generates a special pragmatic style (P-style) of investigations. The P-style lies in the fact that one searches all possible ways of explanation and calculation of the considered phenomenon. Of course, different versions, considered at such an approach, are restricted by the existing mathematical technique and by the possibilities of the researcher's imagination. But these restrictions are essentially slighter, than the restrictions imposed by the classical style (C-style) of investigations. The classical style (C-style) is the style of investigations, which is fully developed in the natural sciences to the end of the XIX century.

Our classification of the investigation styles is rather close to the classification of Lee Smolin [13], who classify types of theories: (1) principal theory and (2) constructive theory. By definition, the principal theory is to be universal: it must be applicable to all phenomena, because it installs the main language, which is used for the nature description. Existence of two different principal theories is impossible.

The constructive theories describe some single phenomena in terms of specific models or equations. The constructive theories are associated with the P-style describing compensating conceptions, whereas the principal theories are associated with the C-style describing conceptions, where the associative delusions are not essential.

Unprejudiced reader will agree that the delusions AD.1-AD.3, having been overcome, are delusions indeed, and that it was worth to overcome them. But it is rather doubtless that he agrees at once that AD.4-AD.7 are also delusions and that they are to be overcome. If it were so, then AD.4-AD.7 have been overcome many years ago. Of course, ADs are undesirable as any other delusions. One should eliminate them, if it is possible. But one should not consider them as misunderstandings, or manifestations of researcher's stupidity. ADs are inevitable attributes of the cognitive processes. ADs were in the past, they exist now, and apparently, they will exist in the future. We should know, how to live with them and to make investigation. The situation resembles the situation with a noise. We transmit information at presence of a noise, and we know that the noise is undesirable, that the noise should be removed, and that, unfortunately, it cannot be removed completely.

One should study associative delusions, their properties and the influence on the style of thinking and on investigations of researchers, which are forced to work under conditions of the associative delusions presence. Investigation of ADs properties and possibilities of their overcoming is a goal of this paper. We begin with detailed investigations of AD.4 .AD.7, to

make sure that they are delusions indeed and to understand how to overcome them. It is very important, because experience of overcoming of AD.2 (Ptolemaic doctrine) shows that the overcoming process is very difficult for scientific community.

Usually one connects these difficulties with a negative role of the Catholic church. B.V. Raushenbach [14] considers that the position of the Catholic church is not the case. It was incompetent in problems of celestial mechanics. It agreed simply with opinion of the most of that time researchers. Most of scientists of that time were priests, and B.V. Raushenbach considers that they used the Catholic church simply as a tool for a fight against proponents of the Copernicus doctrine. Experience of the author in attempts of overcoming of AD.4 - AD.7 shows, that this is B.V. Raushenbach, who is right.

In sections 2 .5 one considers properties of AD.4-AD.7. In the seventh section influence of associative delusions on the style of investigations is considered.

### III. CONCEPTION OF GEOMETRY AND A CORRECT CHOICE OF THE SPACE-TIME GEOMETRY

The conception of geometry (CG) is considered to be the method (a set of rules), by means of which the geometry is constructed. The proper Euclidean<sup>1</sup> geometry can be constructed on the basis of different geometric conceptions.

For instance, one can use the Euclidean axiomatic conception (Euclidean axioms), or the Riemannian conception of geometry (dimension, manifold, metric tensor, curve). One can use the topology-metric conception of geometry (topological space, metric, curve). In any case one obtains the same proper Euclidean geometry. From point of view of this geometry it is of no importance which of possible geometric conceptions is used for the geometry construction.

But if we are going to choose a geometry for the real space-time, it is very important, that the list of all possible geometries, suitable for the space-time description, would be complete. If the true space-time geometry is absent in this list, we are doomed to a choice of a false geometry independently of the method which is used for a choice of the space-time geometry. Thus, a determination of the complete list of all possible geometries is a necessary condition of a correct choice of the real space-time geometry. In turn the determination of the possible geometries list depends on the conception of geometry (CG), which is used for determination of the list of possible geometries. Any of possible CG contains information of two sorts:

- (1) non-numerical information in the form of concepts, axioms and propositions, formulated verbally,
- (2) numerical information in the form of numbers and numerical functions of space points. In different CG this information is presented differently.

<i>title of CG</i>	<i>non-numerical information</i>	<i>numerical information</i>
Euclidean CG	Euclidean axioms	$\emptyset$
Riemannian CG	Manifold, curve coordinate system	$n, g_{ik}(x)$
topology-metric CG	topological space, curve	$\rho(P, Q) \geq 0,$ $\rho(P, Q) = 0, \text{ iff } P = Q$ $\rho(P, Q) + \rho(Q, R) \geq \rho(P, R)$
purely metric CG	$\emptyset$	$\sigma(P, Q) = \frac{1}{2}\rho^2(P, Q) \in \mathbb{R}$

Varying continuously numbers and functions, constituting numerical information of CG, one obtains a continuous set of geometries in the framework of one CG. Each of them differs slightly from the narrow one. Any admissible value of numerical information is attributed to some geometry in the framework of the given CG. One can also change non-numerical information, replacing one axiom by another. But at such a replacement the geometry changes step-wise, and

one should monitor that replacements of one axiom by another do not lead to inconsistencies. It is complicated and inconvenient. It is easier to obtain new geometries in the framework of the same conception, changing only numerical information.

One can see from this table, that different CG have different capacity of the numerical information and generate the geometry classes of different power. The Euclidean CG does not contain the numerical information at all. Vice versa, the purely metric CG contains only numerical information and generates the most powerful class of geometries which will be referred to as physical geometries.

<sup>1</sup> We use the term "Euclidean geometry" as a collective concept with respect to terms "proper Euclidean geometry" and "pseudo-Euclidean geometry". In the first case the eigenvalues of the metric tensor matrix have similar signs, in the second case they have different signs.

The physical geometry has many attractive features. Firstly, it is very simple and realizes the simple attractive idea, that for determination of a geometry on a set of points  $P$  it is sufficient to give the distance  $\rho(P, Q)$  between all pairs  $\{P, Q\}$  of points of the set  $\Omega$ . In fact, the distance  $\rho(P, Q)$  is determined by means of the world function  $\sigma = \frac{1}{2}\rho^2$  on the set  $\Omega \times \Omega$ . In spite of simplicity and attraction of this idea the existence possibility of the purely metric CG was being problematic for a long time. K. Menger [15] and J.L. Blumenthal [16] tried to construct so called distance geometry, which was founded on the concept of distance in a larger degree, than it is made in the topology-metric CG. But they failed to construct the purely metric CG. The reason of the failure was AD.4. The formulation of necessary and sufficient conditions of the geometry Euclideness in terms of the world function  $\sigma$ , given on the set  $\Omega \times \Omega$ , was a crucial step in construction of the purely metric CG. The prove [17, 18, 19] of the fact, that the Euclidean geometry can be constructed in terms of only  $\sigma$  meant a possibility of construction of any physical geometry in terms of  $\sigma$ . It meant existence of the purely metric conception of geometry (CG), which is a monistic conception.

In the framework of purely metric CG all information on geometry is derived from the world function. In particular, if one can introduce a dimension of the space  $\{\Omega, \sigma\}$ , this information can be derived from the world function [19]. From the world function one can derive information on continuity, or discontinuity of the space  $\{\Omega, \sigma\}$ . In the case of continuous geometry the information on the coordinate systems and on metric tensor can be also derived from the world function. In

where  $\rho(P_0, P_1)$  is the distance in  $\mathcal{G}_E$  between the points  $P_0$  and  $P_1$ .

If one considers nondegenerate physical geometry of the space-time, the motion of free particles in such a space-time appears to be stochastic, although the geometry in itself (i.e. the world function  $\sigma$ ) is deterministic. In other words, multivariance (nondegeneracy) of the space-time geometry generates an indeterminism.

In the Riemannian CG the deformation, converting a line into a tube, is forbidden. It is connected with AD.4, according to which the curve is a fundamental object of geometry, and there do not exist such geometries, where the curve would be replaced by

$$\sigma_M(x, x') = \sigma_M(t, \mathbf{x}; t', \mathbf{x}') = \frac{1}{2} \left( c^2 (t - t')^2 - (\mathbf{x} - \mathbf{x}')^2 \right) \quad (3.2)$$

where  $c$  is the speed of the light, and  $x = \{t, \mathbf{x}\}$ ,  $x' = \{t', \mathbf{x}'\}$  are coordinates of two arbitrary points in the space-time.

physical geometry there is an absolute parallelism (which is absent in Riemannian geometries). Besides the physical geometry has a new property-multivariance (nondegeneracy).

The geometry is multivariant (nondegenerate), if at the point  $P_0$  there are many vectors  $\mathbf{P}_0\mathbf{Q}, \mathbf{P}_0\mathbf{Q}', \mathbf{P}_0\mathbf{Q}'' \dots$  which are equivalent to the vector  $\mathbf{AB}$  at the point  $A$ , but vectors  $\mathbf{P}_0\mathbf{Q}, \mathbf{P}_0\mathbf{Q}', \mathbf{P}_0\mathbf{Q}'' \dots$  are not equivalent between themselves. In the degenerate (single-variant) geometry there is only one such a vector  $\mathbf{P}_0\mathbf{Q}, \forall P_0 \in \dots$ .

Multivariance of physical geometry may be conceived as follows. Any physical geometry can be obtained from the Euclidean geometry by means of its deformation (i.e. a change of distance  $\rho(P, Q)$  between the space points). At such a deformation the geometrical objects of Euclidean geometry change their shape. If the obtained physical geometry is degenerate, the Euclidean straight transform to lines, which are curved lines, in general. But it is possible such a deformation, that the straight of  $n$ -dimensional Euclidean space converts into  $(n-1)$ -dimensional tube. For it would be a possible, the straight is to be defined as a set of points, possessing some property of the Euclidean straight. Definition of the straight as a curve, possessing some property of the Euclidean straight prohibits automatically deformation of the Euclidean straight into  $(n-1)$ -dimensional tube and discriminates nondegenerate geometries.

It is easy to see that a segment  $\mathcal{T}_{[P_0P_1]}$  of the straight line in the Euclidean geometry  $\mathcal{G}_E$  is described as follows

a surface. It is in this point, where AD.4 discriminates purely metric CG and physical geometries, generated by this CG. As a corollary the list of possible geometries reduces strongly. The true space-time geometry fall out of the list of possible geometries, and one chooses a false model for the space-time.

In the present time one uses the Riemannian conception for obtaining the space-time geometry. In the simplest case, when one can neglect gravitation, the space-time is uniform, isotropic and flat. In the framework of the Riemannian geometry there is only one flat uniform isotropic geometry. It is the Minkowski geometry, for which the world function has the form:

Thus, in the case of Riemannian CG the problem of choosing space-time geometry does not appear. It is determined uniquely.

The topology-metric CG cannot be applied to the space-time, because it supposes that  $\sigma(P, Q) = \frac{1}{2}\rho^2(P, Q) \geq 0$ , whereas in the space-time there are spacelike intervals, for which  $\sigma(P, Q) < 0$ .

The purely metric CG generates a whole class of uniform isotropic physical geometries, labelled by a function of one argument. In this case the world function has the form

$$\sigma(x, x') = \sigma_M(x, x') + D(\sigma_M(x, x')), \quad (3.3)$$

where  $\sigma_M$  is the world function for the Minkowski space (3.2), and the function  $D$  is an arbitrary function, labelling possible uniform isotropic geometries. These geometries differ one from another in the shape of tubes, obtained as a result of the Euclidean straight deformation. Hence, they differ in the stochasticity character of the free particles motion. For the purely metric CG the problem of choice of the space-time geometry is very important, because there are many uniform isotropic geometries. To set  $D \equiv 0$  in (3.3) and to choose the Minkowski geometry would be incorrect, because in the Minkowski geometry the motion of particles is deterministic. But it is well known that the motion of real microparticles (electrons, positrons, etc.) is stochastic. In other words, experiments with single particles are irreproducible. Only distributions of results, i.e. results of mass experiments with many similarly prepared particles are reproducible. These distributions of results are described by quantum mechanics, constructed on the basis of some additional hypotheses, known as principles of quantum mechanics.

When there are such space-time geometries, where the motion of particles is primordially stochastic, one cannot consider as reasonable such an approach, where at first one chooses the Minkowski geometry with deterministic motion of particles, and thereafter one introduces additional suppositions (quantum mechanics principles), providing a description of the stochastic motion of free particles. It would be more correct to choose the space-time geometry in such a way, that dynamics (statistical description) of stochastic motion of free particles would describe correctly experimental data. As far as the quantum mechanics describes all nonrelativistic experiments very well, it is sufficient to choose the space-time geometry so, that the statistical description of stochastic motion of free particles would agree with predictions of quantum mechanics.

At first sight, it seems that the quantum effects cannot be explained by peculiarities of geometry, because intensity of quantum effects depends on the particle mass essentially, and the mass is such a characteristic of a particle, which is not connected with a geometry. It seems that influence of a geometry on the particle motion is to be similar for particles of any mass. In reality the influence of geometry does not depend on particle mass only in the degenerate geometry

(Minkowski geometry). In the space-time with the degenerate geometry the particle mass is not a geometrical characteristic.

The world tube of the particle with the mass  $m$  is described by the broken world tube  $\mathcal{T}_{br}$ , which is determined by a sequence of the break points  $\{P_i\} i = 0, \pm 1, \pm 2, \dots$ . The adjacent points  $P_i, P_{i+1}$  are connected between themselves by a segment  $\mathcal{T}_{[P_i P_{i+1}]}$  of the straight. This segment is determined by the relation (3.1)

$$\mathcal{T}_{[P_i P_{i+1}]} = \{R | \rho(P_i, R) + \rho(R, P_{i+1}) = \rho(P_i, P_{i+1})\} \quad (3.4)$$

where  $\rho(P_i, P_{i+1}) = \sqrt{2\sigma(P_i, P_{i+1})}$  is the distance between the  $P_i$  and  $P_{i+1}$ . The set of points  $\{P_i\}, i = 0, \pm 1, \pm 2, \dots$  will be referred to as the skeleton of the tube  $\mathcal{T}_{br}$ .

In the proper Euclidean geometry as well as in the Minkowski geometry (for timelike interval  $\rho^2(P_i, P_{i+1}) > 0$ ) the set of points (3.4) forms a segment of the straight line, connecting points  $P_i, P_{i+1}$ . In the nondegenerate geometry the set  $\mathcal{T}_{[P_i P_{i+1}]}$  forms a three-dimensional cigar-shaped surface with the ends at the points  $P_i, P_{i+1}$ .

The vector  $\mathbf{P}_i \mathbf{P}_{i+1} = \{P_i, P_{i+1}\}$  is interpreted as the particle 4-momentum on the segment  $\mathcal{T}_{[P_i P_{i+1}]}$  of the particle world tube  $\mathcal{T}_{br}$ .

$$\mathcal{T}_{br} = \bigcup_i \mathcal{T}_{[P_i P_{i+1}]}. \quad (3.5)$$

The length  $|\mathbf{P}_i \mathbf{P}_{i+1}| = \rho(P_i, P_{i+1}) = \sqrt{2\sigma(P_i, P_{i+1})}$  of the vector  $\mathbf{P}_i \mathbf{P}_{i+1}$  is the geometrical mass  $\mu$  of the particle, expressed in units of length. The universal constant  $b$  connects the geometrical mass  $\mu$  with the usual mass  $m$  of the particle.

$$m = b\mu = b\rho(P_i, P_{i+1}), i = 0, \pm 1, \pm 2, \dots [b] = \text{g/cm} \quad (3.6)$$

All segments  $\mathcal{T}_{[P_i P_{i+1}]}, i = 0, \pm 1, \pm 2, \dots$  has the same length  $\mu = m/b$ . Thus, in general,  $m$  is a geometrical characteristic of the particle, but in the case of the Minkowski geometry one cannot determine the particle mass, using the world line shape, because one cannot determine points  $P_i$  of the world line  $\mathcal{T}_{br}$  skeleton on the basis of the world line shape. In the case of multivariant (nondegenerate) space-time geometry the points  $P_i$  of the skeleton are end points of the cigar-shaped segments  $\mathcal{T}_{[P_i P_{i+1}]}$ . They can be determined via presentation of the broken tube (3.5). Interval  $\rho(P_i, P_{i+1})$  between adjacent points  $P_i$  of the world line skeleton determines the geometrical mass  $\mu$  of the particle.

For a free particle the 4-momenta  $\mathbf{P}_i \mathbf{P}_{i+1}$  and  $\mathbf{P}_{i+1} \mathbf{P}_{i+2}$  of two adjacent segments  $\mathcal{T}_{[P_i P_{i+1}]}$  and  $\mathcal{T}_{[P_{i+1} P_{i+2}]}$  are parallel  $\mathbf{P}_i \mathbf{P}_{i+1} \uparrow \uparrow \mathbf{P}_{i+1} \mathbf{P}_{i+2}$ . In the Minkowski geometry there is only one vector  $\mathbf{P}_{i+1} \mathbf{P}_{i+2}$  of the length  $\mu$ , parallel to timelike vector  $\mathbf{P}_i \mathbf{P}_{i+1}$ . Hence, if the vector  $\mathbf{P}_0 \mathbf{P}_1$  is fixed, all other vectors  $\mathbf{P}_i \mathbf{P}_{i+1}$   $i = 1, 2, \dots$  are determined uniquely. In other words, in the Minkowski geometry the total world line  $\mathcal{T}_{br}$  is determined uniquely, provided one of its segments is fixed. It means that the motion of a free particle in the space-time with Minkowski geometry is deterministic.

In the space-time with multivariant geometry there are many vectors  $\mathbf{P}_{i+1} \mathbf{P}_{i+2}$  of the length  $\mu$ , parallel to the timelike vector  $\mathbf{P}_i \mathbf{P}_{i+1}$ . It means that the end  $P_{i+2}$  of the vector  $\mathbf{P}_{i+1} \mathbf{P}_{i+2}$  is not determined uniquely, even if the vector  $\mathbf{P}_i \mathbf{P}_{i+1}$  is fixed. Other points  $P_{i+3}, P_{i+4}, \dots$  are not determined uniquely also. It means that the broken tube  $\mathcal{T}_{br}$  is stochastic. Thus, the motion of a free particle in the space-time with multivariant (nondegenerate) geometry is stochastic. The character and intensity of the stochasticity depends on the form of the function  $D(\sigma_M)$  in the relation (3.3).

Supposing that the statistical description of stochastic world tubes gives the same result, as the quantum-mechanical description in terms of the Schrödinger equation, one can calculate the distortion function  $D(\sigma_M)$ . The calculation gives [20]

$$D = D(\sigma_M) = \begin{cases} d & \text{if } \sigma_M > \sigma_0 \\ f(\sigma_M) & \text{if } |\sigma_M| \leq \sigma_0 \\ -d & \text{if } \sigma_M \leq -\sigma_0 \end{cases} \quad (3.7)$$

$$d = \frac{\hbar}{2bc} = \text{const} \approx 10^{-21} \text{ cm}, \quad \sigma_0 = \text{const} \approx d$$

Here  $\hbar$  is the quantum constant, and  $b \approx 10^{-17} \text{ g/cm}$  is a new universal constant.  $f(\sigma_M)$  is an arbitrary function of the order  $\sigma_0$ .

From the three-dimensional viewpoint the particle is a pulsating sphere. Period  $T$  of pulsations depends on the particle mass  $m$ . It is determined by the relation  $T = \mu/c = m/(bc)$ , where  $b$  is the universal constant. The maximal sphere radius  $R_{\max} \approx \sqrt{d}$  does not depend on the particle mass. One can assume approximately that in the period  $T$  the sphere radius increases from zero up to maximal value  $R_{\max}$ , and then it reduces to zero. In the period  $T$  the sphere center moves along the straight line uniformly. At the collapse moment a random jump-like change of velocity takes place. In the coordinate system, where the sphere is at rest the velocity jump is equal approximately to  $R_{\max}/T \approx \sqrt{d}/T \approx m^{-1} (\hbar bc/2)^{1/2}$ . The less is the particle mass the larger is the velocity jump. Besides, the period  $T$  depends on the particle mass. As a result for the particle of small mass the random velocity jumps happen more often and have the larger magnitude. Thus, choosing the space-time geometry in the form (3.3), (3.7), one can explain all nonrelativistic quantum

properties effects without referring to quantum principles. Such a space-time geometry is more correct, than the Minkowski geometry, because in this case one does not need additional hypotheses in the form of quantum principles. In such a geometry the quantum constant appears in the theory together with the distortion function (3.7). It is an attribute of the space-time, that agrees with the universal character of the quantum constant  $\hbar$ .

#### IV. DYNAMICAL CONCEPTION OF STATISTICAL DESCRIPTION

As we have mentioned, the choice of the space-time geometry is determined by the condition that the statistical description of the stochastic motion of particles is to coincide with the nonrelativistic quantum-mechanical description. It means that the quantum mechanics is to be represented as a statistical description of randomly moving particles. In the end of XIX century the thermodynamics was presented as a statistical description of chaotically moving molecules. After this representation many researchers thought that something like that can be made with the quantum mechanics. It is a common practice to think that any statistical description is produced in terms of the probability theory. In this point we meet AD.5, where it is supposed that there is no statistical description without the probability theory. Attempts [21, 22] of formulating the quantum mechanics in terms of the probability theory failed. The fact is that, attempting to represent the quantum mechanics as a statistical description of stochastic particle motion, one overlooks usually, that the random component of the particle motion can be relativistic, whereas the regular component remains to be nonrelativistic.

The probability theory, applied successfully to the statistical physics for statistical description of the chaotic molecule motion, is not suitable for a description of the stochastic motion of relativistic particles. The fact is that, the employment of the probability density supposes splitting of all possible system states into sets of simultaneous independent events. In the relativistic theory it cannot be made for a continuous dynamic system, as far as there is no absolute simultaneity in the special relativity. The simultaneity at some coordinate system cannot be used also, because the coordinate system is a method of description. Application of the probability theory and of the conditional simultaneity (simultaneity at some coordinate system) means an application of the statistics to the description methods instead of the necessary calculation of the dynamic system states.

One can overcome the appeared obstacle, rejecting employment of the probability theory at the statistical description. Indeed, the term "statistical description" means only that one considers many



identical, or almost identical objects. Application of the probability theory in the statistical description is not necessary, because it imposes some constraints on the method of the description, that is undesirable. For instance, the probability density must be nonnegative, and sometimes this constraint cannot be satisfied.

In the nonrelativistic physics the physical object is a particle, i.e. a point in the usual space or in the phase one. The density of points (particles) in the space is nonnegative, it is a ground for introduction of the probability density concept. In the relativistic theory the physical object is a world line in the space-time. The density of world lines in the vicinity of some point  $x$  is a 4-vector, which cannot be a ground for introduction of the probability density.

$$dN = j^k dS_k \tag{4.1}$$

where  $dS_k$  is spacelike area at the point  $x$ ,  $dN$  is the flux of world line through the area  $dS_k$ . the vector  $j^k$  describes the density of world lines in vicinity of the point  $x$ . The alternative version, when any world line is considered to be a point in some space  $\mathcal{V}$  of world lines, admits one to introduce the concept of the probability density in the space  $\mathcal{V}$  of world lines. But such a description is non-local, as far as two world lines, coinciding everywhere except for some remote regions, are represented by different points in  $\mathcal{V}$ , and this points are not close, in general. In other words, such an introduction of the probability is very inconvenient.

To get out of this situation, one needs to reject from employment of the probability theory at the statistical description. Instead of the probabilistic conception the dynamical conception of statistical

description (DCSD) should be used. Instead of the stochastic system  $\mathcal{S}_{st}$ , for which there are no dynamic equations, one should use a set  $\mathcal{E}[N, \mathcal{S}_{st}]$ , consisting of large number  $N$  of identical independent systems  $\mathcal{S}_{st}$ . It is known as the statistical ensemble of systems  $\mathcal{S}_{st}$ . The statistical ensemble  $\mathcal{E}[N, \mathcal{S}_{st}]$  forms a deterministic dynamical system, for which there are dynamic equations, although they do not exist for elements  $\mathcal{S}_{st}$  of the statistical ensemble. The statistical description lies in the fact that one investigates properties of  $\mathcal{E}[N, \mathcal{S}_{st}]$  as a deterministic dynamic system, and on the basis of this investigation one makes some conclusions on properties of its elements (stochastic systems  $\mathcal{S}_{st}$ ). As far as one investigates a dynamic system (statistical ensemble) and its properties, there is no necessity to use the concept of probability.

Concept of the statistical ensemble has been introduced by J. W. Gibbs [23]. According to his definition an ensemble (also statistical ensemble) is an idealization consisting of a large number of virtual copies (sometimes infinitely many) of a system, considered all at once, each of which represents a possible state that the real system might be in. In other words, a statistical ensemble is a probability distribution for the state of the system.

Along with the statistical ensemble  $\mathcal{E}[N, \mathcal{S}]$  of systems  $\mathcal{S}$ , or even instead of it, one can introduce the statistically averaged dynamic system  $\langle \mathcal{S} \rangle$ , which is defined formally as a statistical ensemble  $\mathcal{E}[N, \mathcal{S}]$ , ( $N \rightarrow \infty$ ), normalized to one system. Mathematically it means that, if  $\mathcal{A}_E[N, d_N \{X\}]$  is the action for  $\mathcal{E}[N, \mathcal{S}]$ , then

$$\langle \mathcal{S} \rangle : \mathcal{A}_{\langle \mathcal{S} \rangle} [d \{X\}] = \lim_{N \rightarrow \infty} \frac{1}{N} \mathcal{A}_E [N, d_N \{X\}], \quad d \{X\} = \lim_{N \rightarrow \infty} d_N \{X\}$$

is the action for  $\langle \mathcal{S} \rangle$ , where  $X$  is a state of a single system  $\mathcal{S}$ , and  $d_N \{X\}$  is the distribution, describing in the limit  $N \rightarrow \infty$  both the state of the statistical ensemble  $\mathcal{E}[N, \mathcal{S}]$  and the state of the statistically averaged system  $\langle \mathcal{S} \rangle$ .

Replacement of the statistical ensemble  $\mathcal{E}[N, \mathcal{S}]$  by the statistically averaged system  $\langle \mathcal{S} \rangle$  is founded on the insensibility of the statistical ensemble to the number  $N$  of its elements, under condition that  $N$  is large enough. The statistically averaged system  $\langle \mathcal{S} \rangle$  is a kind of a statistical ensemble. Formally it is displayed in the fact that the state of  $\langle \mathcal{S} \rangle$ , as well as the state of the statistical ensemble  $\mathcal{E}[N, \mathcal{S}]$  is described by the distribution  $d_N \{X\}$ ,  $N \rightarrow \infty$ , whereas the state of a single system  $\mathcal{S}$  is described by the quantities  $X$ , but not by their distribution. Using this formal criterion, one can distinguish between the individual dynamic system  $\mathcal{S}$  and the statistically averaged system  $\langle \mathcal{S} \rangle$ .

To obtain the quantum mechanics as a statistical description of stochastic motion of particles, one needs to make one important step more. It is

necessary to introduce the wave function  $\psi$ , which is the main object of quantum mechanics. Usually the wave function is introduced axiomatically, i.e. as an object, satisfying a system of axioms (principles of quantum mechanics). For this reason the meaning of the wave function is obscure. To clarify it, one has to introduce the wave function as an attribute of some model.

If  $\mathcal{S}$  is a particle (deterministic or random), then the statistical ensemble  $\mathcal{E}[N, \mathcal{S}]$  of particles  $\mathcal{S}$ , or statistically averaged particle  $\langle \mathcal{S} \rangle$  are continuous dynamic systems of the fluid type. It is well known [24], that the Schrödinger equation can be represented as an equation, describing irrotational flow of some ideal fluid. In other words, the wave function can be considered to be an attribute of irrotational fluid flow. One can show [9], that the reciprocal statement (any fluid flow can be described in terms of a wave function) is also valid. The rotational flow is described by a many-component wave function. In other words, at the rotational flow the spin appears.

As far as the statistically averaged particle  $\langle \mathcal{S} \rangle$  is a dynamical system of a fluid type, the wave function appears to be a description method of this fluid  $\langle \mathcal{S} \rangle$ . In order the statistical description of the particle  $\mathcal{S}$  coincides with the quantum mechanical description, it is necessary to find the state equation of the fluid  $\langle \mathcal{S} \rangle$ , which is determined in turn by the form of the distortion function  $D$ . Corresponding calculation was made in the paper [20]. This calculation determines the form (3.7) of the distortion function. Then one obtains the conception, which will be referred to as the model conception of quantum phenomena (MCQP). For the conventional presentation of quantum mechanics the term "the axiomatic conception of quantum phenomena" (ACQP) will be used.

Dynamical conception of statistical description (DCSD) generates a less informative description, than the probabilistic statistical description in the sense that some conclusions and estimations, which can be made at the probabilistic description, cannot be made in the framework of DCSD. One is forced to accept this, because one cannot obtain a more informative description. The fact, that the quantum mechanics is perceived as a dynamical (but not as a statistical, i.e. probabilistic) conception, is connected with the employment of DCSD. In turn application of DCSD is conditioned by "relativistic roots" of the nonrelativistic quantum mechanics. The "dynamic perception" of quantum mechanics takes place in the framework of both conceptions MCQP and ACQP. Let us note that DCSD is an universal conception in the sense that it can be used in both relativistic and nonrelativistic cases.

## V. IDENTIFICATION OF INDIVIDUAL PARTICLE WITH THE STATISTICALLY AVERAGED ONE

"Dynamical perception" of quantum mechanics leads to the fact that the statistically averaged particle  $\langle \mathcal{S} \rangle$ , described by the wave function, is considered to be simply a real particle  $\mathcal{S}$ . The question, why the real particle  $\mathcal{S}$  is described by the wave function  $\psi$ , i.e. by a continuous variable (but not by position and momentum as an usual particle), is answered usually, that it is conditioned by the quantum character of the particle. One refers usually to the quantum mechanics principles, according to which the quantum particle state is described by the wave function  $\psi$ , whereas the classical one is described by a position and a momentum. At this point we meet AD.6, when one does not differ between the statistically averaged particle  $\langle \mathcal{S} \rangle$  and the individual particle  $\mathcal{S}$ .

As a corollary of such an identification the properties of  $\langle \mathcal{S} \rangle$  and  $\mathcal{S}$  are confused, and an object with inconsistent properties appears [25]. As long as we work with mathematical technique of quantum mechanics, dealing only with  $\langle \mathcal{S} \rangle$ , no contradictions and no paradoxes appear. But as soon as the measurement

process is described, where both objects  $\langle \mathcal{S} \rangle$  and  $\mathcal{S}$  appear, the ground for inconsistencies and paradoxes come into existence. Combinations of contradictory properties may be very exotic.

There are at least two different measurement processes. The measurement ( $\mathcal{S}$ -measurement), produced under an individual system  $\mathcal{S}$ , leads usually to a definite result and does not influence the wave function, which is an attribute of the statistically averaged system  $\langle \mathcal{S} \rangle$ . The measurement ( $M$ -measurement), produced under the statistically averaged system  $\langle \mathcal{S} \rangle$ , is a set of many  $\mathcal{S}$ -measurements, produced under individual systems  $\mathcal{S}$ , constituting the statistically averaged system  $\langle \mathcal{S} \rangle$ . The  $M$ -measurement changes the wave function of the system  $\langle \mathcal{S} \rangle$  and does not lead to a definite result. It leads to a distribution of results.

The following situation takes place the most frequently. One considers that the wave function describes the state of an individual system, and a measurement, produced under individual system, changes the state (wave function) of this system. As a result a paradox, connected with the wave function reduction and known as the Schrödinger cat, appears. A corollary of such an approach is so called many-world interpretation of quantum mechanics [26, 27].

## VI. IDENTIFICATION OF HAMILTONIAN AND ENERGY AT THE SECONDARY QUANTIZATION OF RELATIVISTIC FIELD

The energy of a closed dynamic system is defined as the integral from the time component  $T^{00}$  of the energy-momentum tensor

$$E = \int T^{00} d\mathbf{x} \quad (6.1)$$

The energy is a very important conservative quantity. The Hamilton function (Hamiltonian) of the system is a quantity canonically conjugate to the time, i.e. the quantity, determining the time evolution of the system. By their definitions the Hamiltonian  $H$  and the energy  $E$  are quite different quantities. But in the non-relativistic physics (classical and quantum) these quantities coincide in many cases. For instance, the energy of a particle in a given potential field  $U(\mathbf{x})$  has the form  $E = \mathbf{p}^2/2m + U(\mathbf{x})$ . The Hamiltonian of the particle has the same form. On the ground of this coincidence an illusion appears, that the energy  $E$  of a dynamical system plays a role of the quantity, determining its evolution, i.e. the role of its Hamiltonian  $H$ . An illusion appears that the energy and the Hamiltonian are synonyms, i.e. two different names of the same quantity. In reality, if the particle is described in terms of world lines, and the world line (not a particle) is the basic object of dynamics, the energy  $E$  and

Hamiltonian  $H$  are different quantities [28]. The identification of energy and Hamiltonian of a free particle is admissible, if there is no pair production.

The identification of energy and Hamiltonian is used in the relativistic quantum theory, where there is a pair production, and such an identification cannot be used. For instance, it is common practice to consider [29], that in the dynamic system  $\mathcal{S}_{KG}$ , described by the Klein-Gordon equation, the particle energy may be both positive and negative. A ground for such an statement is the fact that the flat wave in  $\mathcal{S}_{KG}$  has the form

$$\psi = Ae^{\frac{i}{\hbar}(k_0t - \mathbf{k}\mathbf{x})}, \quad c = 1 \quad (6.2)$$

where the quantity  $k_0 = \sqrt{m^2 + \mathbf{k}^2}$  is interpreted as an energy. The light speed  $c = 1$ .  $k_0$  may be both positive and negative. The statement that the energy may be negative is made in spite of the fact that the energy-momentum tensor component

$$T^{00} = m^2 \psi^* \psi + \nabla \psi^* \cdot \nabla \psi \quad (6.3)$$

which enters in the expression (6.1), takes only nonnegative values. In reality, the quantity  $k_0$  is a time component of the canonical momentum (or Hamiltonian), which can have any sign. But the particle energy is always nonnegative.

Thus, in the given case one has the associative delusion (AD.7), which lies in the fact that the properties of Hamiltonian are attributed to the energy. As long as such an identification is produced on the verbal level, it leads only to a confusion in interpretation and nothing more. But in the quantum field theory (QFT) such an identification has a mathematical form, and it has far-reaching consequences for the secondary quantization of the scalar field  $\psi$ . The additional constraint  $E = H$  leads to the fact that the zigzaglike world line, describing the pair production, is divided into segments. Each of segments is timelike. Some of segments have  $H = k_0 = \sqrt{m^2 + \mathbf{k}^2} > 0$ . They describe particles. Another segments have  $H = k_0 = \sqrt{m^2 + \mathbf{k}^2} < 0$ . they describe antiparticles. The problem, which can be described by finite number of objects (world lines), is described in the contemporary theory by indefinite number of objects (particles and antiparticles). As a result such a problem can be described only by the perturbation theory methods. The vacuum state appears to be nonstationary for the case of the second quantization of nonlinear Klein-Gordon equation. Nonstationary vacuum state, describing empty space-time, is nonsense. In order to remove this absurd situation, one considers that the vacuum state is filled by virtual particles. Hence, existence of mysterious virtual particles is a corollary of additional constraint  $E = H$ .

The second quantization without the constraint  $E = H$  admits one to reduce the problem of pair production to a set of problems containing one world line, two world lines and so on [7]. These problems can

be solved without a use of the perturbation theory. The condition  $E = H$  is a associative delusion, when the relation, which is valid in the case, when the pair production is absent, is extended to the case, when the pair production does exist.

Overcoming of AD.7 was the first overcoming (1970) among all overcoming of AD.4 - AD.7. It was important, because it showed that there may be associative delusions in the contemporary theoretical physics. The most contemporary physicists believe that there are no mistakes in fundament of contemporary theoretical physics. They believe that one needs to invent new ideas, which will help us to overcome problems of the contemporary theoretical physics. Overcoming of AD.7 showed discovery of associative delusions in the fundament of the theoretical physics and their overcoming is most important problem of theoretical physics, which may change direction of fundamental investigation.

Let me describe how I succeeded to overcome AD.7. This overcoming took place in 1970. Description of this overcoming is interesting from the viewpoint, how difficult this overcoming is for the scientific community. This overcoming was carried out consciously on basis of understanding that in the relativistic theory a physical object is world line (WL)<sup>2</sup>, but not a pointlike particle in the three-dimensional space. I took this truth from the book of V. A. Fock. [30]. Later I found confirmation of this viewpoint in papers of Stueckelberg [31] and Feynman [32]. In general, such a viewpoint was in keeping with my style of geometrical thinking. This brought up the question: "Is it possible to describe pair production in terms of classical relativistic mechanics?" The pair production process is described by a turn of a world line in the time direction. It was well known. It was necessary to invent such an external field which could carry out this turn. It was clear, that adding an arbitrary field to the action of charged particle in a given electromagnetic field  $A_i$

$$\mathcal{A}[q] = \int \left\{ -mc \sqrt{g_{ik} \dot{q}^i \dot{q}^k} + \frac{e}{c} A_i \dot{q}^i \right\} d\tau, \quad \dot{q} \equiv \frac{dq}{d\tau} \quad (6.4)$$

one could not carry out such a turn. The fact is that, at the turn in time the world line becomes to be spacelike near the turning point. On the other hand, under the sign of radical in (6.4) must be a nonnegative quantity. It means, that  $g_{ik} \dot{q}^i \dot{q}^k \geq 0$  and, hence the world line is to be timelike (or null). In order the world line might be spacelike, the external field is to be introduced under sign of radical in (6.4). Then the expression under sign of radical may be positive even in the case, when  $g_{ik} \dot{q}^i \dot{q}^k < 0$ . I introduced the external field under the sign of radical, writing the action in the form

<sup>2</sup>designations WL is used for the world line, considered as a fundamental object

$$\mathcal{A}[q] = \int \left\{ -mc \sqrt{g_{ik} \dot{q}^i \dot{q}^k} - \alpha f(q) + \frac{e}{c} A_i \dot{q}^i \right\} d\tau, \quad (6.5)$$

where  $f$  is an external scalar field, and  $\alpha$  is a small parameter, which tends to zero at the end of calculations. At the properly chosen field  $f$  the expression under the radical can be positive even at  $g_{ik} \dot{q}^i \dot{q}^k < 0$ . It appeared that at the properly chosen field  $f$ , the world line turned in time indeed. This turn is conserved at  $\alpha \rightarrow 0$ . The direct calculations [28] showed that at such a description the particle energy was positive always, but the time component  $p_0$  of the canonical momentum and the particle charge  $Q = e \text{sgn}(\dot{q}^0)$  depended on sign of derivative  $\dot{q}^0$ , i.e. they were different for particle and antiparticle. It was rather sudden that the WL charge  $Q$ , defined as a source of the electromagnetic field by the relation  $Q = \int \delta \mathcal{A} / \delta A_0(\mathbf{x}) d\mathbf{x}$ , did not coincide with the constant  $e$ , incoming to the action, although at the correct description this was to be just so, because the particle and antiparticle had opposite sign of the charge. One can obtain coincidence of energy  $E$  and  $p_0$ , if one cuts the whole world line into segments, responsible for particles and antiparticles, and changes the sign of the parameter  $\tau$  on the segments, responsible for antiparticles, remaining  $\tau$  without a change on segments, responsible for particles. After change of the  $\tau$  sign the segments with changed  $\tau$  ceases to be a solution of dynamic system (6.5). The particles and antiparticles become to be described by different dynamic systems.

This simple example shows, that there are two possibilities of description

- (1) To consider the world line (WL) to be a physical object. Then particle and antiparticle are two different states of WL, distinguishing by signs of the charge  $Q$  and by signs of the canonical momentum component  $p_0$ . The energy is positive in both cases, so restriction  $E = H$  is not used.
- (2) To consider the particle and the antiparticle to be different physical objects, described by two different dynamic systems. In this case one uses restriction  $E = H$ .

Imposition of the constraint  $E = H$  provided automatically fragmentation of the world line into particles and antiparticles, describing them as different physical objects, i.e. in terms of different dynamic systems. This was valid in classical physics. This must be valid in the quantum theory.

It was unclear for me, what was a use of the identification of energy with Hamiltonian. Why does one cut WL to obtain indefinite nonconservative number of particles and antiparticles instead of fixed number of physical objects (WL)? From the formal viewpoint it is more convenient to work with constant number of objects, than with alternating number of them. It was evident for me, that impossibility of working in QFT without the perturbation theory was connected directly

with the fact that numbers of particles and antiparticles were not conserved separately. What for does one need to impose the condition  $E = H$  and to restrict one's capacity, if one could impose no constraints? (Then I did not consider, that the condition  $E = H$  might appear to be incompatible with dynamic equations).

It was necessary to discuss the paper with colleagues dealing with QFT, and I submitted my report to seminar of the theoretical department of the Lebedev Physical Institute, where there were many good theorists. At my report at the session I was surprised by the following circumstance. Nobody believed that the pair production effect could be described in terms of classical mechanics. Although my calculations were very simple, they cast doubt on their validity. It was decided to transfer my report to next session. One of participants of the seminar was asked to verify my calculations and to report on the next session together with continuation of my report. Mistakes in my calculations were not found, and I completed successfully my report at the next session. After the session I seemed that the attention of participants of the seminar was attracted to the problem of possibility of pair production description in terms of classical physics, whereas the main problem, i.e. application the constraint  $E = H$  in QFT, remained outside the scope. Corresponding my paper was published [28], but, as far as I know, nobody paid any attention to it.

It was necessary to quantize nonlinear relativistic field without a use of the condition  $E = H$  and to verify, if such a way of quantization had advantages over the conventional way, using this condition. It happened that such a quantization could be carried out without a use of normal ordering and perturbation theory [7]. The vacuum state appeared to be stationary. A possibility of quantization without the perturbation theory impressed. But I shall not be cunning and say directly, that I had no illusions about results of my work. In that time (beginning of seventieth) I assumed that the problem of the quantum mechanics relativization (i.e. unification of quantum theory with the relativity theory) had no solution. I assumed that the quantum mechanics was something like relativistic Brownian motion, and the relativistic quantum theory should be developed in direction of statistical description of this relativistic motion [2].

My work on the secondary quantization of the nonlinear relativistic field was undertaken with the goal to manifest that the conventional way of the QFT development was a way to blind alley. The logic of my action was as follows. One quantizes the nonlinear field, using only principles of nonrelativistic quantum mechanics and ignoring any additional suppositions. One advances as far as possible. There were a hope that the quantization without the perturbation theory admitted one to clarify real problems of QFT and, maybe, to solve some of them.

The fact was that the use of the perturbation theory did not permit one both to state exactly problems of QFT and to solve them. The problems of collisions were the main problems of QFT. To state the collision problem, it was necessary to formulate exactly what was a particle and what was an antiparticle. According to quantum mechanics principles it is necessary to define for this the operator  $N_p^i$  of the 4-flux of particles and the operator  $N_a^i$  of the 4-flux of antiparticles. After such a definition one can state the problem of collisions. Surprisingly, it appeared that nobody tried to introduce these operators. Instead of this there were cloudy consideration about the interaction cut off at large time  $t \rightarrow \pm\infty$ . Thereafter these considerations about cut off were substituted by manipulations with *in*- and *out*-operators, that did not clarify the statement of the collision problem.

Even in the excellent mathematically rigorous book by F. A. Berezin [33] the collision problem was stated in terms of perturbed  $H$  and nonperturbed  $H_0$  Hamiltonian  $H_0$  describes the dynamic system, that corresponds to interaction cut off at  $t \rightarrow \pm\infty$ . Of course, all this was only a reflection of the whole situation in QFT. I asked my colleagues dealing with QFT, how could one think in terms of the perturbation theory. They answered obscurely. I understood, that some problems could not be solved exactly. I was ready to use any methods of approximation (including the perturbation theory) by the indispensable condition, that the problem be stated exactly, but not in approximate terms. To state a problem in approximate concepts and terms was beyond my understanding.

As soon as the nonlinear field was quantized [7], results of my paper were reported on a session of the seminar of the theoretical department of Lebedev Physical Institute. Although the secondary quantization was produced without the perturbation theory, most of participants considered my results to be unsatisfactory on the ground that at the quantization one violated the condition

$$[\varphi(x), \varphi^*(x')]_- = 0, \quad (x - x')^2 < 0 \quad (6.6)$$

which was interpreted usually as the causality condition. Indeed, if at the quantization the condition  $E = H$  is not imposed, the commutator between the dynamic variables at the points, separated by a spacelike interval  $x - x'$  cannot (and in some cases must not) vanish. Let me explain this in the example of pair production, described in terms of classical physics, where the pair production is described by time zigzag of the world line. In this case the commutator (6.6) associates with the Poisson bracket. If the condition  $E = H$  is imposed and the quantization is carried out in terms of particles and antiparticles, the dynamic variables  $X$  and  $X'$  at the points, separated by a spacelike interval  $x - x'$ , relate to different dynamic systems always. The corresponding Poisson bracket  $\{X, X'\}$  between any dynamic variables

$X$  and  $X'$  at these points vanishes. In the case of quantization in terms of world lines the dynamic variables  $X$  and  $X'$  at the points, separated by a spacelike interval  $x - x'$ , can belong to the same world line, i.e. to the same dynamic system. Then the variables  $X$  and  $X'$  correspond to different values  $\tau$  and  $\tau'$  of evolution parameter  $\tau$ . In this case the dynamic variables  $X$  at the point  $x$  are expressed via dynamic variables  $X'$  at the point  $x'$ , and there exist such a dynamic variables  $X_1$  at  $x$  and  $X_2'$  at  $x'$ , that the Poisson bracket  $\{X_1, X_2'\}$  does not vanish. The condition (6.6) is violated with a necessity.

Thus, a fulfillment or a violation of the condition (6.6) is an attribute of a description. It coincides with the causality condition (i.e. with the objectively existing relation) only at imposition of the condition  $E = H$ . Unfortunately, I failed to convince my opponents of dependence the relation (6.6) on the way of description, although I tried to do this at the session and in discussions thereafter. Later on I had understood, that in this case one met associative delusion, when the properties of description are attributed to the object in itself. Unfortunately, it happens that many researchers meet difficulties at overcoming of AD, and as I am understanding now, the P-style used by the most researchers of QFT is a reason of these difficulties. Besides, formulating the condition (6.6) in terms of quantum theory, it is very difficult to discover that this condition is an attribute of a description, but not a causality condition.

Thus, I had overcome AD.7, but the scientific community as whole had not overcome it. I did not see a necessity in further convincing my colleagues to refuse from imposition of the condition  $E = H$  at quantization. At first, I was convinced that the refusal itself from  $E = H$  did not solve main problems of QFT. My belief, that QFT did not enable to solve the unification problem of quantum theory with relativity and that the statement of this problem was false in itself, became stronger. Secondly, I myself did not know exactly what must replace this problem of unification. I had only a guess on this account. I might not to convince a person, dealing with QFT and devoting essential part of his life to this, that he had chosen a wrong way. Without pointing a right way, such a convincing was useless.

There were once more an important circumstance which influenced strongly on my interrelations with colleagues dealing with QFT. The fact is that, since I had discovered incorrectness of imposition of the condition  $E = H$ , I met difficulties at reading papers on QFT. When I began to read any paper and discovered that the condition  $E = H$  was used there (this was practically in all papers on QFT), my attention was cut off subconsciously, and I could not continue conscious reading. My reading became absent-minded, and I needed to bend my every effort to turn on my attention and continue a conscious reading. I

do not know to what extent such a reaction is my individual property, but tearing off the papers using  $E = H$  led gradually to my allergy to reading of papers on QFT. I stopped to read them, although I was interesting QFT always, and questioned my colleagues about QFT development at any suitable case.

Why did I overcome associative delusions comparatively easy? Apparently, it was connected with that I was an adherent of the C-style and ignored instinctively approaches, which were used by the P-style. It is difficult for me to say, whether this adherence to the C-style was innate, or it was a result of my education.

At first I did not think on styles of investigations. I assumed simply, that one needed to investigate a physical phenomenon honestly, but not to dodge, substituting calculations by conjectures. Maybe, my instinctive adherence to the C-style was so large, that penetrated to my subconsciousness and generated allergy to reading papers on QFT.

Maybe, my successes in overcoming of different ADs was conditioned by consecutive application of C-style, essence of which could be expressed by the Newton's words: "I do not invent hypotheses"

## VII. ON STYLES OF INVESTIGATION

Considerations of the conventional investigation style look approximately as follows. Let us introduce an additional supposition and study its consequences for theory and experiment. If the consequences are positive, the additional supposition is accepted and introduced into the theory. If the consequences are negative, the additional sup-position is removed and a new additional supposition is considered. Such additional suppositions were: normal ordering, renormalizations, increase of the space-time dimension with the subsequent compactification, strings, etc. This style of investigation: additional supposition with subsequent test of its consequences will be referred to as P-style (pragmatic style) of investigation. Such a style is characteristic not only for the QFT development. In the beginning of XX century the quantum mechanics development was carried out also by means of P-style. The quantum mechanics developed, fighting against the classical style (C-style) of investigations, established to the end of XIX century. In this fight the P-style gained a victory over the C-style, which played a role of representative of classical (nonquantum) physics. Successors of Ptolemy used the P-style, whereas successors of Copernicus used the C-style. The competition of successors of Ptolemy with the successors of Copernicus was at the same time a competition between P-style and C-style. Then the C-style gained the victory. C-style reached its fullest flower to the end of XIX century. At the investigations of

quantum phenomena in the XX century C-style gave the way to P-style.

Why do two different styles of investigation exist? Why does the investigation C-style or the investigation P-style gain alternatively the competition? The answer is as follows.

C-style is a style of investigations in the framework of a consistent theory. It puts in the forefront the consistency of a theory. C-style restricts suggestion of additional suppositions (hypotheses), insisting, that additional suppositions be consistent with primary principles of a theory. (Let us recall the Newton's words: "I do not invent hypotheses"). In virtue of its requirement rigidity the C-style has the more predictable force, than the P-style, where these requirements are not so rigid. Among the C-style requirements there are ethic requirements to researchers. For instance, a researcher, which publishes insufficiently founded paper, containing arbitrary (i.e. not following from the primary principles) suppositions, risks losing his scientific face.

Adherents of the C-style pay attention to fundamental problems of a theory, and in particular, to results and predictions of the theory, which are important for its further development. Solutions of concrete practical problems are considered to be not so important, because a solution of any special problem is a formal application of primary principles and mathematical technique to conditions of the new problem, and nothing beyond this. Such a relation of the researcher, using the C-style, to a solution of special problems is founded on his confidence that the primary principles are valid and the theory is consistent.

The predictability of the C-style, rigidity of its requirements and its self-reliance are true, provided the primary principles of a theory are true. If the primary principles contain a mistake, some predictions of the theory appears to be false. It forces onto searching for a mistake, which may occurs in the primary principles or in the conclusion of corollaries from them. The most frequently a mistake is discovered in incorrect application of the primary principles.

But if the mistake in conclusions of a theory (discrepancy between predictions of the theory and experiment) has not been discovered for a long time, the necessity of the cognition progress and necessity of improvement of the terminology for the experimental data description generate a more pragmatic style (P-style) of investigations.

The P-style puts in the forefront a possibility of the experimental data explanation, what is obtained usually by introduction of additional suppositions. The theory consistency is considered to be not so important, although the representatives of the P-style declare, that they tend to elimination of inconsistencies, but it does not succeeded always, and it is considered to be a less defect, than impossibility of the experiment explanation. The P-style admits an introduction of additional

suppositions, even if they appear to be inconsistent with primary principles. It is important only, that they were useful and led to explanation of experimental data. The P-style imposes essentially more slight requirements to researchers. For instance, the scientific reputation of a researcher does not lack or lacks slightly, if writing a very good paper, he writes thereafter several mediocre or even incorrect papers. Predictability of the P-style is essentially less, than that of the C-style, as far as P-style admits only a "short logic" (short logical chain of considerations). For instance, it is widely believed among researchers dealing with quantum theory that essentially new result can be obtained, only suggesting some essentially new supposition in the framework of quantum theory. The idea that a novelty may be found in the primary principles (i.e. outside the framework of quantum theory) and the new result is a corollary of a long logical chain of considerations is perceived as something unreal.

Pragmatism of the P-style manifests itself in setting in the forefront a solution of concrete practical problems. It is supposed that a young talent gifted researcher is to solve concrete problems, whereas solution of fundamental problems is supposed to be a work for elderly experienced researchers. According to such a viewpoint usually one ignores and does not discuss facts and results which are important for further development of a theory, but which do not deal directly with its practical applications. Behind such a relation one can see an uncertainty of the P-style representatives in the primary principles of a theory and in its consistency. If a practical problem fails to be solved, the P-style representatives are ready to suggest additional suppositions and even to revise the primary principles.

The P-style appears to be more effective, only if the C-style appears to be in-effective. The last takes place, if the primary principles contain either mistake or defect. In other words, the C-style is more effective, than the P-style only at absence of obstacles (systematic noise). The P-style is noise-resistant, under presence of the "systematical noise" it appears to be more effective, than the C-style. In the period of a long P-style dominance a theory degenerates. Accumulating many additional suppositions, contradicting each other, the theory gives up step-by-step its predictable force and capacity of valid development. Situation was such in the time of dominance of the Ptolemaic doctrine. The same situation takes place now in the quantum field theory.

In general, the C-style is more effective and predictable, provided the primary principles are valid. The P-style is useful in the relation, that it works even in the case, when there is a mistake in the primary principles, and C-style cannot work. In this case the P-style admits one to introduce new adequate concepts and terminology for descriptions of experiments that cannot be explained by the theory, based on the primary principles. Finally, investigations, realized by means of

the P-style, help one to discover mistake in the choice of primary principles and produce a necessary revision.

Any style of investigations is conservative. It is worked out by a researcher in the course of all his research activity. If the researcher used the P-style, i.e. he uses essentially the trial and error method, he gets accustomed hardly to rigid restrictions of the C-style. Vice versa, a researcher, using the C-style in his work, gets accustomed to work with consistent conceptions. It is very difficult for him to pass to more free P-style and to invent new additional supposition which are necessary for explanations of new experiments. Conservatism of the investigation style leads to a conflict, when the dominating investigation style changes. For instance, in the time of Ptolemy the P-style dominated. Discovery of AD.2 needed to construct a consistent conception of the celestial mechanics which would be free of arbitrary suppositions. The conflict between the successors of Ptolemy and those of Copernicus was in the same time a conflict between the investigation styles.

Now practically all researchers dealing with relativistic QFT use P-style. They perceive difficultly arguments of the C-style proponents, having found inconsistencies and mistakes in primary principles of the quantum theory.

To describe my research activity briefly, one should say, that using C-style, I put consecutively into effect the idea of geometrization of physics [34], and this agreed completely with the general line of the physics development in XIX .XX centuries.

## VIII. OVERCOMING OF ASSOCIATIVE DELUSIONS IN THE CONTEMPORARY THEORETICAL PHYSICS

Lee Smolin formulated five unsolved important problems of contemporary theoretical physics [13]:

*Problem 1:* Unification of general relativity and quantum theory (quantum gravitation)

*Problem 2:* Rationale of quantum mechanics.

*Problem 3:* Unification of particles and fields.

*Problem 4:* Explanation how to choose free constants in the standard model of elementary particle physics.

*Problem 5:* Explanation of the phenomenon of dark matter and dark energy.

Lee Smolin supposed that these problems should be solved in the framework of a constructing theory (a theory developed by the P-style). However, discovery of AD.4-AD.7 and overcoming of them admits one to solve all these problem, using C-style of investigation. In reality, only AD.5 and AD.4 are used in solution of these problems. AD.6 and AD.7 are specific associative delusions of the quantum theory. They are not used, when overcoming of AD.5 admits one to found quantum mechanics and to solve the second problem

of Smolin. Foundation of quantum mechanics as a statistical description of classical stochastic particles solve the first Smolin problem, because in the framework DCSD the gravitational field is not to be quantized. The first problem of Smolin does not exist simply. The third problem exists also only in the framework of quantum theory. The fourth problem is a specific problem of the standard model. It is absent in the skeleton conception of elementary particles [35]. The fifth problem is solved by discovery and overcoming of AD.4. As a result the general relativity is extended on the case of physical space-time geometries [36]. In the extended general relativity there are no dark holes, because the collapse of stars and other cosmic objects stops by the induced antigravitation [37]. Antigravitation is absent in general relativity. As a result one is forced to invent the dark energy, to explain the advanced expansion of universe. In the extended general relativity there is antigravitation, and there are no reason to invent the dark energy.

As to dark matter, it is the tachyon gas. Overcoming of AD.4 admits one to consider the geometry of Minkowski as a physical geometry, where spacelike vectors are multivariant. Then tachyons exist, but a single tachyon cannot be detected, because of infinite amplitude of its world line wobbling. However, the tachyon gas can be detected by its gravitational field [38]. The tachyon gas forms the dark matter [39].

Thus, overcoming of associative delusions admits one to solve important problems of theoretical physics. It appears that there are defunct problems (like the problem 1). It is the problem only from the viewpoint of researchers, using P-style. Besides, there are problems generated by the suppositions generated by associative delusions.

## IX. CONCLUDING REMARKS

Thus, the associative delusions (AD) accompanied the cognition process. Although one should tend to eliminate ADs, but, apparently, the complete elimination of them is impossible. In the case of impossibility of this elimination of ADs, AD leads to appearance of additional compensating hypotheses and to a construction of compensating (Ptolemaic) conceptions. Appearance of Ptolemaic conceptions leads to a generation of a special P-style of investigations, suitable for work with Ptolemaic conceptions. The P-style is simultaneously a style of investigations and a style of thinking. On one hand, the P-style is "noise-resistant"(suitable for work with Ptolemaic constructions, containing false suppositions), but on the other hand, it is less predictable, than C-style. In the course of some time one can pursue investigations, using P-style. But, thereafter the Ptolemaic conceptions stops to be effective. It becomes necessary to find and to overcome corresponding AD, returning to C-style. If the P-style was existing for a long

time and several generations of researchers had educated on its application, the overcoming of AD and returning to the C-style will be a difficult process. One needs to be ready to this.

After discovering AD the subsequent revision of existing theory may appear to be very essential. If it concerns the space-time geometry, the revision may lead even to a change of a world outlook. Transition from the space-time with the primordially deterministic particle motion to the space-time with the primordially stochastic motion is already a ground for a change of the world outlook. If earlier it was necessary to explain the stochasticity, starting from the determinism of the world, then now one should explain deterministic phenomena on the basis of primordial stochasticity of the world.

## REFERENCES RÉFÉRENCES REFERENCIAS

1. Yu.A. Rylov, Logical reloading. What is it and what is a profit from it? *Int. J. Thor, Phys.* DOI: 10.1007/s10773.014.2039.3
2. Yu. A. Rylov "Quantum Mechanics as a theory of relativistic Brownian motion" *Ann. Phys. (Leipzig)*. 27, 1-11, (1971).
3. Yu. A. Rylov, Quantum mechanics as relativistic statistics.I: The two-particle case. *Int. J. Theor. Phys.* 8, 65-83, (1973).
4. Yu. A. Rylov, Non-Euclidean method of the generalized geometry construction and its application to space-time geometry in *Pure and Applied Differential geometry* pp.238-246. eds. Franki Dillen and Ignace Van de Woestyne. Shaker Verlag, Aachen, 2007. Available at *e-print Math.GM/0702552*.
5. Yu. A. Rylov, Metrical conception of the space-time geometry. *Int. J. Theor, Phys.* DOI: 10.1007/s10773-014-2228-0.
6. Yu. A. Rylov, Structural approach to the elementary particle theory. in *Space-Time Ggeometry and Quantum Events* Ed.Ignazio Licata. pp.227-315, Nova Science Publishers Inc. ISBN 978-1-63117-455-1.
7. Yu. A. Rylov, "On quantization of non-linear relativistic field without recourse to perturbation theory".*Int. J. Theor. Phys.*, 6, 181-204, (1972).
8. Yu. A. Rylov, "Pair production problem and canonical quantization of nonlinear scalar field in terms of world lines", *e-print hep-th/0106169*.
9. Yu. A. Rylov, "Spin and wave function as attributes of ideal fluid", *J. Math. Phys.* 40, 256-278, (1999).
10. Yu. A. Rylov, "Dynamic disquantization of Dirac equation", *e-print quant-ph/0104060*.
11. Yu. A. Rylov, Is the Dirac particle composite?.*e-print physics/0410045*.
12. Yu. A. Rylov, Is the Dirac particle completely relativistic?.*e-print/physics/0412032*.



13. L. Smolin, *The trouble with physics: the rise of string theory, the fall of science, and what comes next*. Houghton Mi- in, Boston, 2006.
14. B. V. Raushenbach, "Let experts dispute", *Christianity and science*, IX International Christmas educative readings. Collection of conference reports. Moscow, 2001, pp. 153-170. (in Russian)
15. K. Menger, Untersuchen über allgemeine Metrik, *Mathematische Annalen*, 100, 75-113, (1928).
16. L. M. Blumenthal, *Theory and Applications of Distance Geometry*, Oxford, Clarendon Press, 1953.
17. Yu. A. Rylov, "Extremal properties of Synge's world function and discrete geometry." *J. Math. Phys.* 31, 2876-2890, (1990).
18. Yu. A. Rylov "Metric space: classification of finite subspaces instead of constraints on metric." *Proceedings on analysis and geometry*, Novosibirsk, Publishing House of Mathematical institute, 2000. pp. 481-504, (in Russian), English version *e-print math.MG/9905111*.
19. Yu. A. Rylov, "Description of metric space as a classification of its finite subspaces", *Fundamental' naya i Prikladnaya Matematika*, 7, no.4, 1147-1175, (2001). (in Russian).
20. Yu. A. Rylov, Non-Riemannian model of space-time responsible for quantum effects. *J. Math. Phys.* 32, 2092-2098, (1991).
21. J. E. Moyal, Quantum mechanics as a statistical theory. *Proc. Cambr. Phil. Soc.*, 45, 99,
22. I. Fényes, Probability-theoretical foundations and interpretation of quantum theory. *Zs. f. Phys.*, 132, 81, (1952).
23. J. W. Gibbs, *Elementary Principles in Statistical Mechanics*. 1902, New York: Charles Scribner's Sons.
24. E. Madelung, "Quanten theorie in hydrodynamischer Form *Z.Phys.* 40, 322-326, (1926).
25. Yu. A. Rylov, Incompatibility of the Copenhagen interpretation with quantum formalism and its reasons *Concepts of Physics* 5, iss.2, 323-328, (2008). ISSN1897-2357. See also *e-print /physics/0604111*.
26. H. Everett *Rev. Mod. Phys* 29, 454, (1957); Reprinted in *Quantum Theory and Measurement* (Eds J A Wheeler, W H Zurek) (Princeton, N.J.: Princeton University Press. 1983).
27. B. S. DeWitt, N. Graham (Eds) *The Many-Worlds Interpretation of Quantum Mechanics* (Princeton, N.J.: Princeton University Press, 1973).
28. Yu. A. Rylov "On connection between the energy-momentum vector and canonical momentum in relativistic mechanics". *Teoreticheskaya i Matematicheskaya Fizika*. 2, 333-337. (in Russian). *Theor. and Math. Phys. (USA)* 5,333, (1970) (translated from Russian)
29. S. S. Schweber, *An introduction to relativistic quantum field theory*. Row, Peterson and Co. N.Y. 1961.
30. V. A. Fock, *Theory of space, time and gravitation*. GITTL, Moscow, 1955.
31. E. C. G. Stueckelberg, *Helv. phys. Acta*, 15, (1942).
32. R. P. Feynman, *Phys. Rev.* 76, 749-759, (1949).
33. F. A. Berezin, *Method of secondary quantization*. Nauka, Moscow, 1965. (in Russian).
34. Yu. A. Rylov, Physics geometrization in microcosm: discrete space-time and relativity theory (Review) in *Hypercomplex numbers in physics and geometry* 8, iss. 2 (16,) pp.88-117 (2011). (In Russian). English version in *e-print/1006.1254v2*.
35. Yu. A. Rylov, Discrete space-time geometry and skeleton conception of particle dynamics . *Int. J. Theor. Phys.* 51, 1847-1865, (2012), See also *e-print 1110.3399v1*.
36. Yu. A. Rylov, General relativity extended to non-Riemannian space-time geometry. *e-print 0910.3582v7*.
37. Yu. A. Rylov, Induced antigravitation in the extended general relativity. *Gravitation and Cosmology*, Vol. 18, No. 2, pp. 107.112, (2012).
38. Yu. A. Rylov, Dynamic equations for tachyon gas, *Int. J. Theor. Phys.* 52, 3683- 3695, (2013).
39. Yu. A. Rylov, Tachyon gas as a candidate for dark matter, *Vestnik RUDN ser. Mathematics. Informatics, Physics* (2013), iss 2 pp.159-173 (In Russian).

This page is intentionally left blank



## Application of Electrical Resistivity Method in Designing a Structural Model for a Proposed Filling Station Site, Akure, Southwestern Nigeria

By Akinlalu, A. A., Adegbuyiro A & Obore, A. A.

*Federal University of Technology*

**Abstract-** The subsurface characterization of sub-soil of a proposed filling station was carried out along Ilesha road, Akure, Ondo State with the aim of designing a structural model for the filling station. To achieve this, Electrical Resistivity method using Dipole-Dipole and Schlumberger Vertical Electrical Sounding (VES) was employed. Dipole-Dipole run through five (5) traverses in the north-south direction. A total of twenty-five (25) VES points were established with five (5) at each traverses. Dipole-Dipole data were used to generate 2-D resistivity structure image with resistivity ranging from 19 ohm-m – 487 ohm-m at the topsoil and 19.0 ohm-m – 80 ohm-m at the weathered layer. The VES data were interpreted through partial curve matching and computer iteration. The interpreted data were used to generate geo-electric sections showing that the geo-electric sequence comprise of topsoil, weathered layer, partly weathered/fracture basement and fresh basement. The resistivity ranging from 22 ohm-m – 83 ohm-m at the topsoil, 12 ohm-m – 507 ohm-m at the weathered layer, 185 ohm-m - 864 ohm-m at the partly weathered/ fracture layer and 1987 ohm-m – 33693 ohm-m for the fresh basement.

**Keywords:** subsurface characterization, structural model, filling station.

**GJSFR-A Classification:** FOR Code: 040499p



*Strictly as per the compliance and regulations of :*



RESEARCH | DIVERSITY | ETHICS

# Application of Electrical Resistivity Method in Designing a Structural Model for a Proposed Filling Station Site, Akure, Southwestern Nigeria

Akinlalu, A. A. <sup>α</sup>, Adegbuyiro A <sup>σ</sup> & Obore, A. A. <sup>ρ</sup>

**Abstract-** The subsurface characterization of sub-soil of a proposed filling station was carried out along Ilesha road, Akure, Ondo State with the aim of designing a structural model for the filling station. To achieve this, Electrical Resistivity method using Dipole-Dipole and Schlumberger Vertical Electrical Sounding (VES) was employed. Dipole-Dipole run through five (5) traverses in the north-south direction. A total of twenty-five (25) VES points were established with five (5) at each traverses. Dipole-Dipole data were used to generate 2-D resistivity structure image with resistivity ranging from 19 ohm-m – 487 ohm-m at the topsoil and 19.0 ohm-m – 80 ohm-m at the weathered layer. The VES data were interpreted through partial curve matching and computer iteration. The interpreted data were used to generate geo-electric sections showing that the geo-electric sequence comprise of topsoil, weathered layer, partly weathered/fracture basement and fresh basement. The resistivity ranging from 22 ohm-m – 83 ohm-m at the topsoil, 12 ohm-m – 507 ohm-m at the weathered layer, 185 ohm-m - 864 ohm-m at the partly weathered/ fracture layer and 1987 ohm-m – 33693 ohm-m for the fresh basement. The resistivity at the second layer was used to produce an isoresistivity map of the area. The study proved that Electrical Resistivity method can serve as an important tool in designing a model for the construction of a filling station.

**Keywords:** subsurface characterization, structural model, filling station.

## I. INTRODUCTION

Due to the high quest for power and fuel, construction of filling station has become the business of the day especially in a fast developing city like Akure, Southwest, Nigeria. The building of filling station is the final stage on the Exploration & Production (E&P) cycle. This structure has both positive and negative impact on the society and its proposed location.

Positive impacts of the development of a fuel service station and convenience store at this location are likely to include the injection of spending into the local economy, the creation of jobs and the value of increased convenience and efficiency. These likely impacts are examined by investigating three key economic indicators– namely, gross domestic product

(GDP), employee remuneration and job creation. The negative impacts are the after effects it leaves on the society if not well controlled. Seepage and leakage of these products might get to the water table and therefore contaminate the aquifer. This can spread to the community and cause harm to the community. Most investigations are done after pollution to delineate the rate and extent of contaminant infiltration. This is done by various geophysical methods.

These effects and survey could be limited or eliminated if subsurface characterizations using geophysical methods are done before the construction is carried out. This subsurface characterization helps to know suitable soil that is less corrosive, the flow of ground water and competent layer for super structure if need be. This helps in the planning of the filling station, to reduce or eliminate threats to the community. Various geophysical methods has been used in recent past to characterize the subsurface (Ayolabi, et.al., 2009; Bale, et.al., 2010; Oyedele, et.al., 2011; Bayode, et.al., 2012; Eluyemi, et.al., 2012, Adeyemo and Omosuyi, 2012; Adelusi, et.al., 2013; Adelusi, et.al., 2014) . Al-Garni (2010) used magnetic method to delineate the subsurface structure and depth to source rock. This research work is targeted at using the electrical resistivity method in characterizing the subsurface and subsequently generate a plan for the proposed filling station.

## II. SITE DESCRIPTION, TOPOGRAPHY, CLIMATE AND VEGETATION

The study area is located at Adebowale gas junction along Ilesha road, in Akure south local government area of Ondo State, Southwestern Nigeria. It lies on Northings N804960-N804915 and Eastings E739080-E739040 of the universal transverse Mercator (UTM). The study area is readily accessible through Oba-Adesida road, Akure (Figure 1).

Topographic elevation values ranges from 356m-361m above the sea level. The study area is located sub-equatorial climatic belt of the tropical rain-forest with evergreen and broad-leaved trees and with luxuriant growth layer arrangement (Balogun, 2003). The area is characterized by uniform high temperature and heavy, well distributed rainfall throughout the year. The

Author <sup>α</sup> <sup>ρ</sup>: Department of Applied Geophysics, Federal University of Technology, Akure, Nigeria.

e-mail: ayokunleakinlalu@gmail.com

Author <sup>σ</sup>: Nigerian Institute of Mining and Geosciences, Jos, Nigeria.

average annual temperature ranges between 24°C and 27°C, while the annual rainfall is mostly conventional, peak twice in July and September and varies between 1500mm and 2000mm per annum (Balogun, 2003).

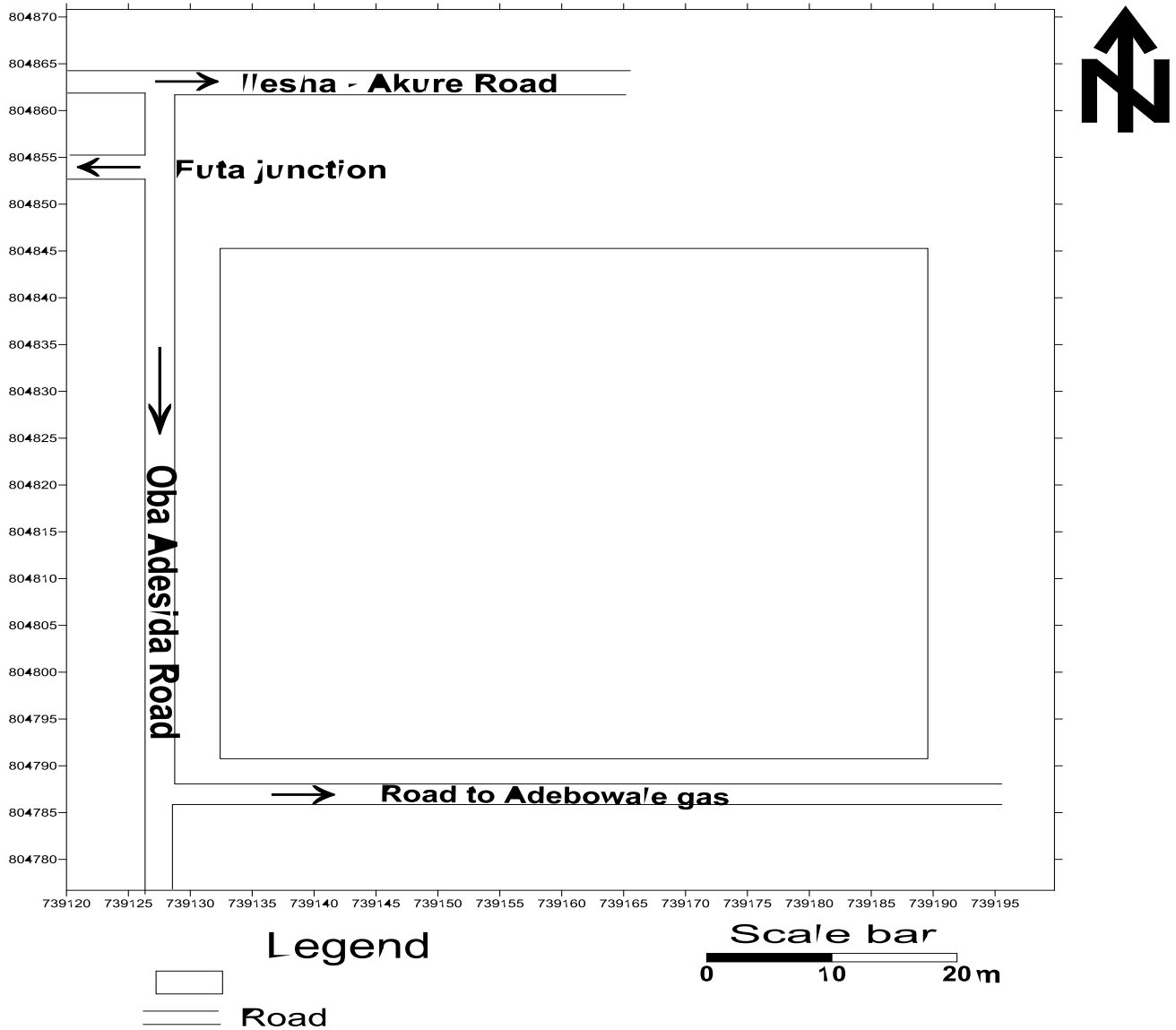

Figure 1: Base Map of the Study Area

### III. GEOLOGIC SETTING

The study area is located within the crystalline basement complex terrain of southwestern Nigeria (Figure 2). The area is generally underlain by basement rocks categorized by Rahaman (1976, 1989) as migmatite gneiss, quartzite, pelitic schist, biotite granite, charnockite, granite gneiss and porphyritic granites. There are no visible crystalline rock outcrops in the study area. The area is covered by reddish-brown lateritic clay.

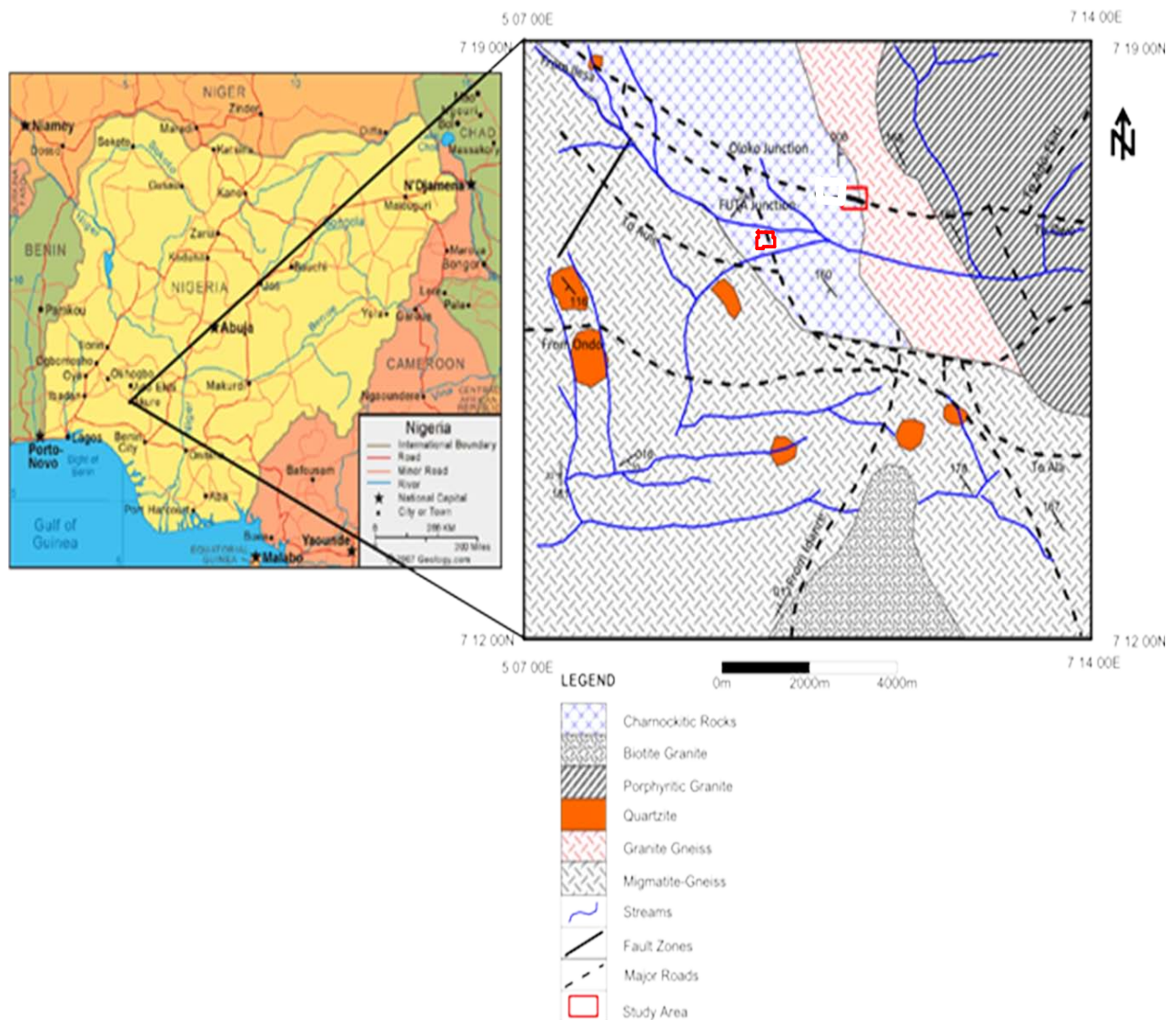

Figure 2: Simplified geological map of Akure, showing the study area (Modified after Owoyemi, 1996), Left: Administrative map of Nigeria

#### IV. MATERIALS AND METHODS

Ohmega resistivity meter was employed to acquire the data in the study area. Electrical resistivity techniques adopted are the vertical electrical sounding (VES) using the Schlumberger configuration and the combine Horizontal Profiling (HP) and VES using the Dipole-Dipole Configuration. Vertical electrical sounding (VES) survey is a measure of variation of electrical resistivity with depth. This is achieved by a gradual increase in the current electrode spacing about a fixed center of electrode spread. Dipole – Dipole resistivity profiling technique was also adopted in the research to determine the lateral and vertical variation in ground apparent resistivity beneath each specific traverse lines. The study area with a coverage of 45m X 40m (1800m<sup>2</sup>) was gridded and Dipole-Dipole traverse lines were established along five (5) traverses in the N-S direction. Twenty five (25) Vertical Electrical Sounding (VES) points

were occupied across the study area with five VES points occupied on each of the traverse at 9m interval(Figure 3). Electrode spacing of  $a=5$  with  $n$  ranging from 1-5 was adopted for the dipole-dipole configuration while VES electrode spacing ( $AB/2$ ) was varied from 1-100m. The location of each of the sounding was taken in Universal Transverse Mercator (UTM) coordinate system with the aid of the “GARMIN 12” channel personnel navigation Global Positioning System (GPS) unit.

The obtained VES data were quantitatively interpreted using partial curve matching and iteration modeling technique with the aid of Win Resist geophysical software (Patrax and Nath, 1998, Vander Velpen, 2004,). The apparent resistivity dipole-dipole data were inverted using DIPPRO SOFTWARE (DIPPRO™ 4.0, 2000) which produced the field data pseudo section, theoretical data pseudo section and the 2-D resistivity structure images of the subsurface.

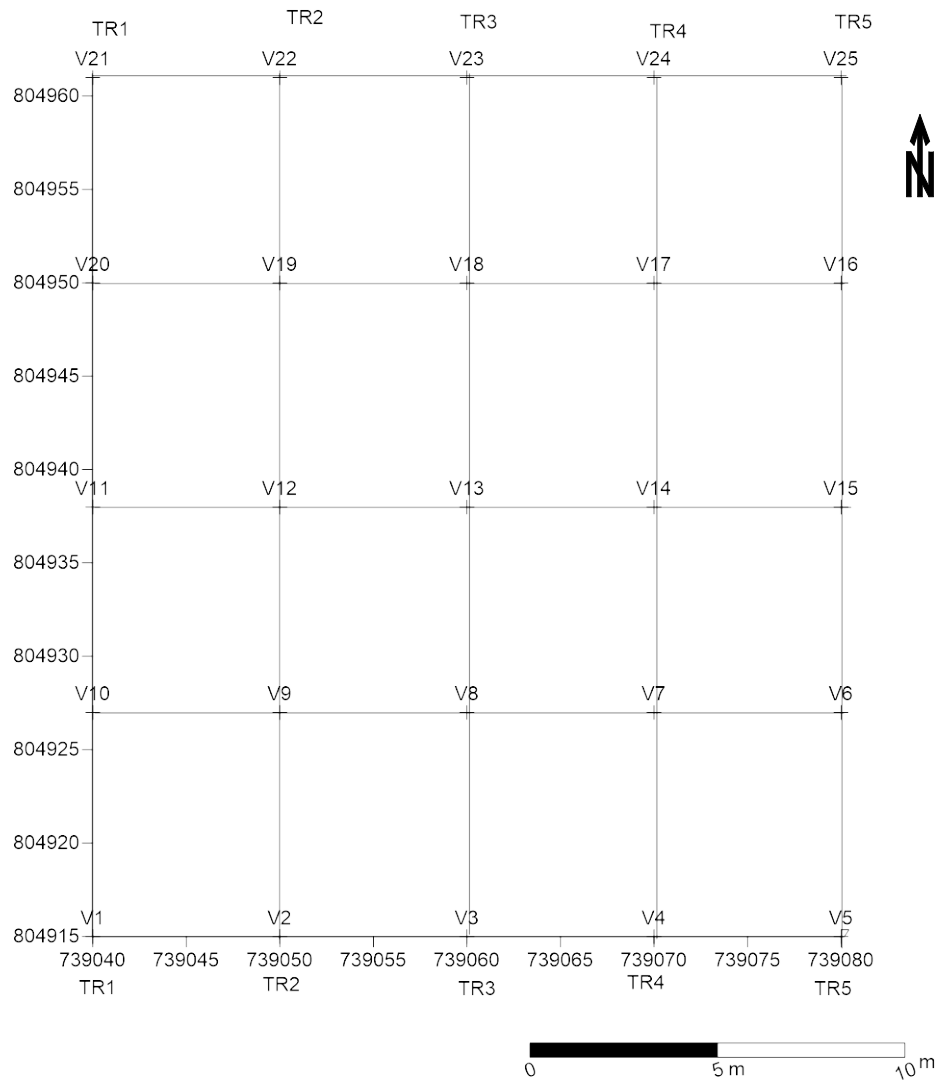

Figure 3: Data Acquisition Map of the Study Area

## V. RESULTS AND DISCUSSION

### a) Subsurface Characterization

2-D Resistivity structure image produced from the Dipole-Dipole data were correlated with the geo-electric sections to characterize the sub-surface and identify suitable location for tank burial and competent layers for super structures and fuel pumps that will be erected on the proposed filling station site.

Figure 4 shows the 2-D resistivity structure along traverse 1 with resistivity ranging from 20 – 120 ohm-m which is generally low. Around 10m, the resistivity is relatively higher than the other points. This attribute suggest that the medium is highly weathered/Clayey and thus can store water because it is an impervious layer and with time lead to the corrosion of the tank. The geo-electric section shows that the area is characterized by four distinct geologic sequences namely; topsoil, weathered layer, partly weathered/fractured layer and a fresh basement. The resistivity of the top soil range from 22 – 46 ohm-m, for

the weathered layer it ranges from 18 – 415 ohm – m, the partly weathered/fractured layer has a resistivity of range of 295 – 480 ohm – m and the fresh basement ranges from 2999 – 14856 ohm – m. For proper correlation, the 2-D resistivity structure imaging the depth up to 5m of the geo-electric section will be taken to consideration. Looking at the geo-electric section from VES 11 to VES 1, resistivity is very low which correspond to that of the 2-D resistivity structure image.

## (2-D Resistivity Structure)

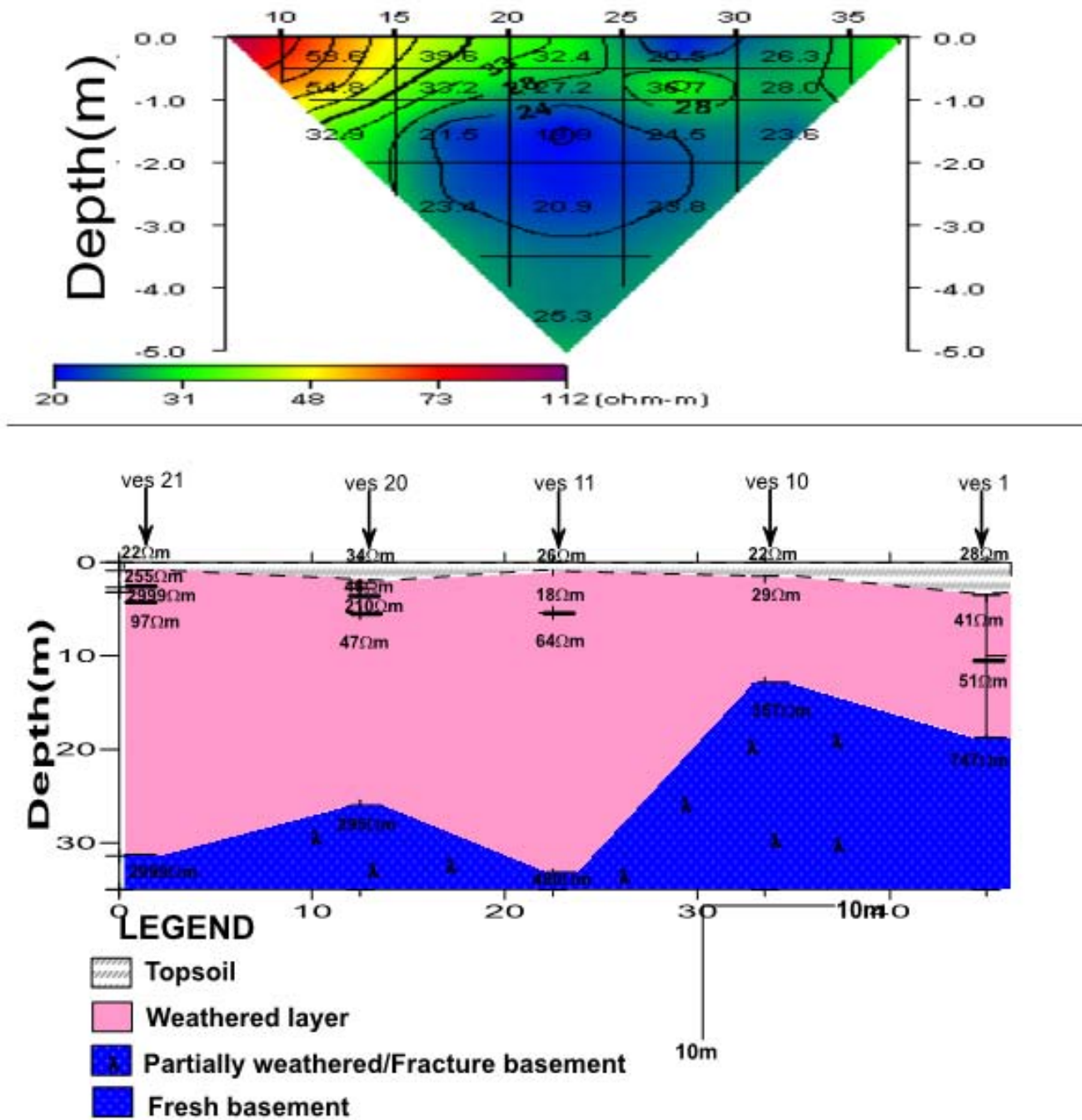

Figure 4: 2-D Resistivity Structures and Geo-Electric Section along Traverse 1

Figure 5 shows the 2-D resistivity structure along traverse 2 with resistivity value ranging from 19-123 ohm -m which is from very low to moderate resistivity. Around 10m, the resistivity is higher than the resistivity observed along the traverse. At about 1 – 2m deep around 15- 35 m, a very low resistivity was observed. The geo-electric section shows thin overburden from VES 12 – VES 2 and the overburden increases from VES 2 to VES 22. The top soil has

resistivity ranging from 21– 28 ohm –m, the weathered layer have resistivity ranging from 12 – 496 ohm-m. The fresh basement lies between partly weathered/fractured layers with resistivity ranging from 2634 – 2325 ohm – m. At depth of 5m, resistivity decreases from VES 12 – VES 2 which correlate with the 2-D resistivity structure image of the subsurface. However, the medium having very low resistivity is very small in size.



Figure 6 shows the 2-D resistivity structure along traverse 3 with the resistivity values ranging from 29- 106 ohm – m which is of low resistivity throughout the traverse. Depth around 1 – 2m at distance 25 – 35m display very low resistivity. The geo-electric section shows that most points sounded has thin overburden apart from VES 13 and VES 3. VES 13 might be suitable for groundwater because it has a partly weathered/ fractured rock. The topsoil has resistivity ranging from

25 – 39 ohm – m, the weathered layer has resistivity values ranging from 28 – 600 ohm –m. The partly weathered / fractured rock was delineated in VES 23, VES 18, VES 13& VES 8. Resistivity in this medium ranges from 87 – 8793 ohm –m. At about 5m on the geo-electric section, VES 18, VES13 & VES 8 show relatively low resistivity in the medium which can be related to the 2-D resistivity image of the subsurface. The medium is of moderate resistivity.

### (2-D Resistivity Structure)

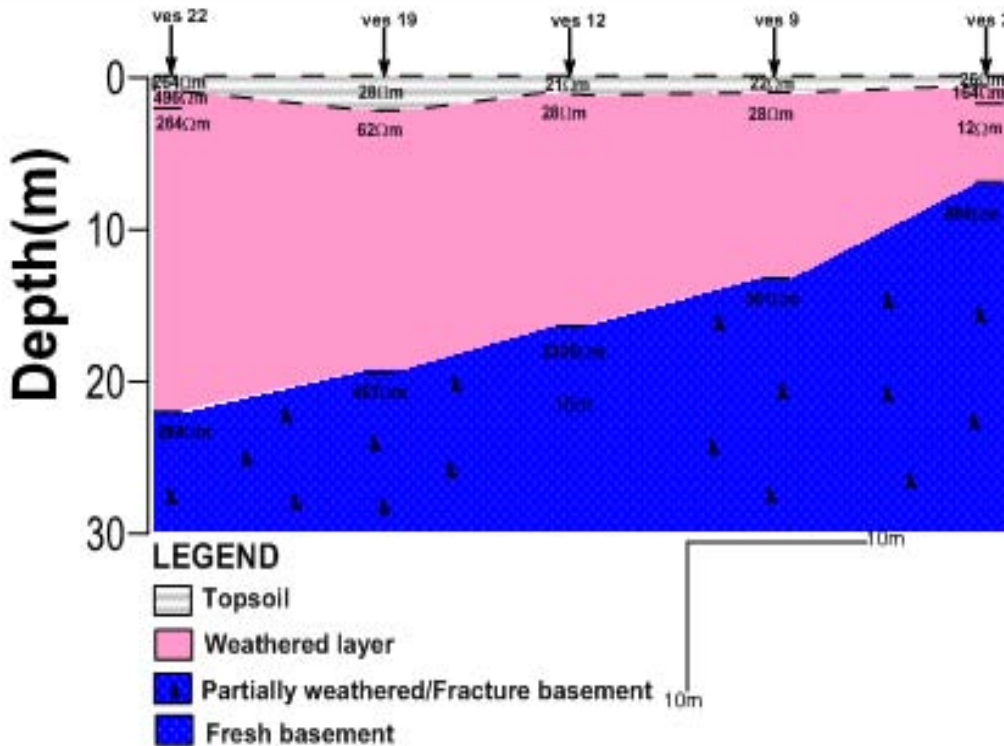
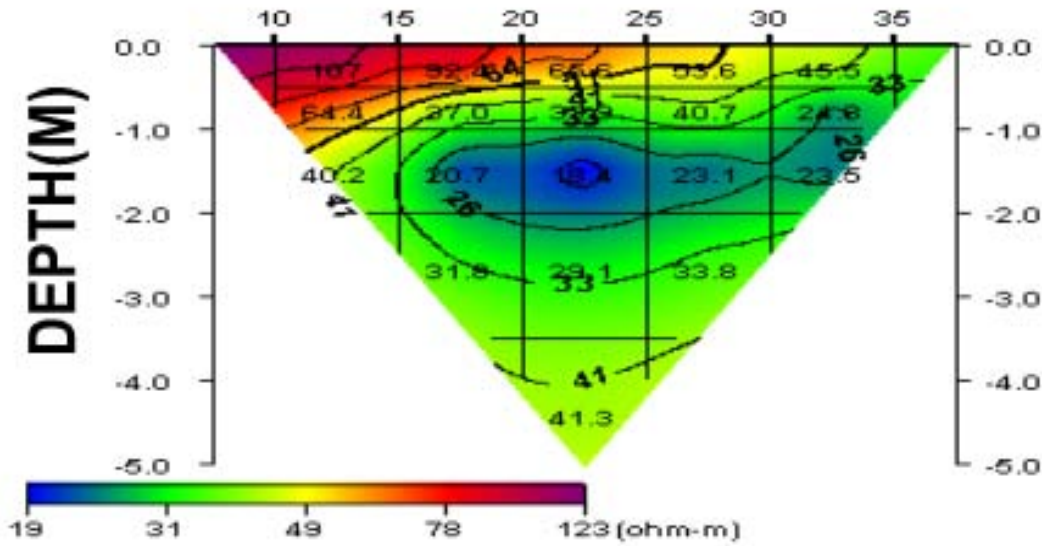

Figure 5: 2-D Resistivity Structure and Geo-Electric Section along Traverse 2

## (2-D Resistivity Structure)

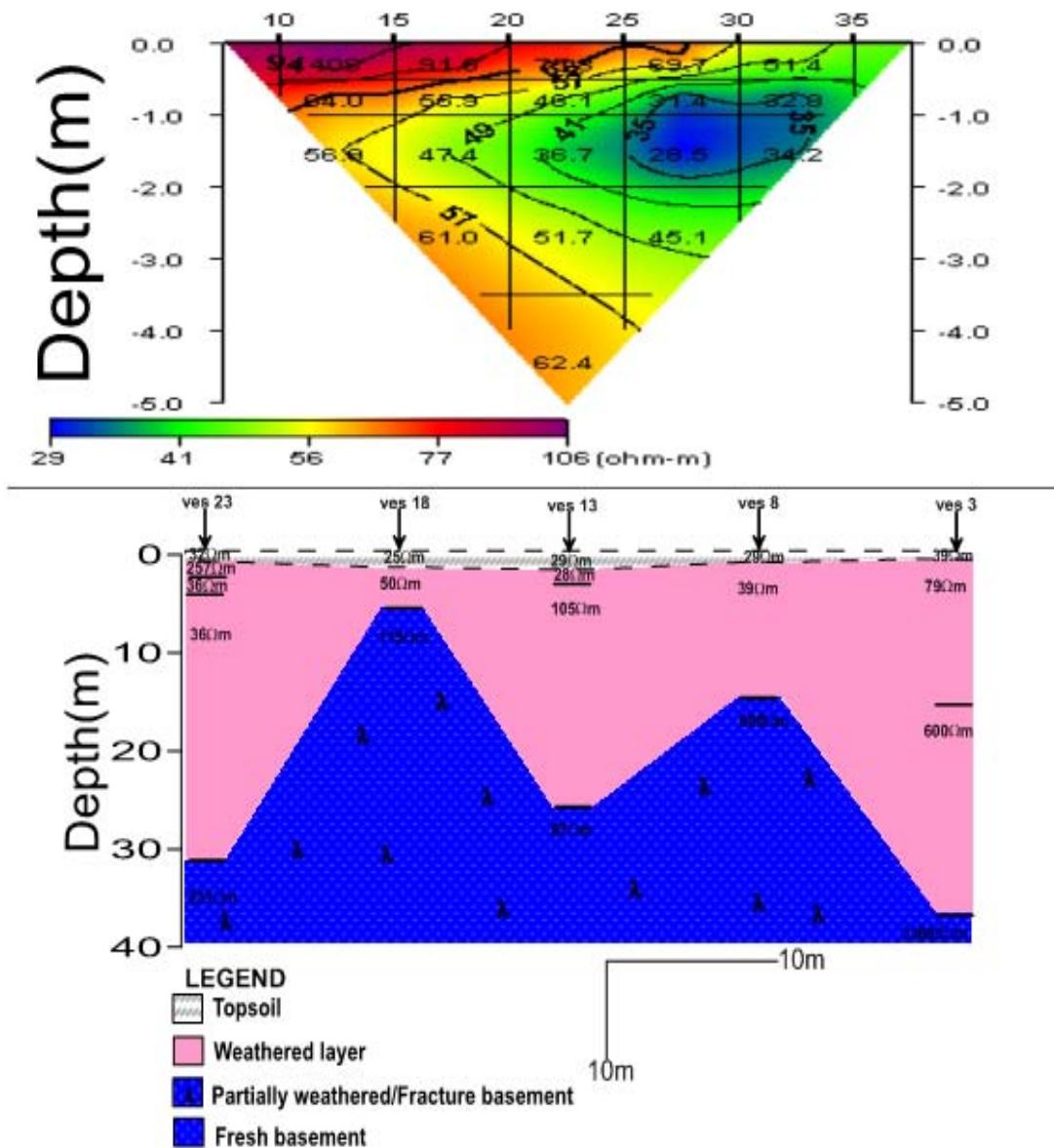

Figure 6: 2-D Resistivity Structures and Geo-Electric Section along Traverse 3

Figure 7 reveal the 2-D resistivity structure along traverse 4 with resistivity value ranging from about 49 – 195 ohm- m which indicates that the region contains areas of medium to relatively high resistivity values. From distance 0 – 35 m, relatively high resistivity values are present at depth of about 0 – 2.5m with the highest resistivity values of 195 ohm-m occurring around distance 10m. From depth of 2.5m downward, low resistivity medium was delineated. The presence of relatively high resistivity in an appreciable depth shows that the area/region is competent and can harbor engineering structure (building) and can be used for tank burial because water cannot be stored in this medium. The geo-electric section has an appreciable depth and thickness of overburden except for VES 24

which has thin overburden. Regions of thick overburden over a fractured layer shows possible zone for groundwater accumulation. At depth ranging from 1-5m moderate to high resistivity values were delineated around the VES stations. These high and moderate resistivity value shows that the region is competent and can sustain engineering structures (building).

Figure 8 shows the 2-D resistivity structure with resistivity ranging from 19 – 516 ohm – m which shows that resistivity is from very low to relatively high resistivity. High resistivity was present across the region at a depth of 0-2.5m. However, very low resistivity typical of weathered materials like clay or a fractured zone typifies the location at depth ranging from 2.5 – 5 m at distance between 10-25m. However, beyond 25m, the

relatively high resistivity zones tend to continue with depth and thus suggesting a competent layer for engineering structure (building), and also for tank burial at that location. The geo-electric section shows that the topsoil has resistivity varying from 47 – 83 ohm –m, for the weathered layer the resistivity ranges from 28 – 439 ohm – m, the partly weathered/ fractured basement and fresh basement have resistivity ranging from 185 – 9578 ohm- m. Thin overburden were observed around VES16 and VES15 and appreciable overburden thickness for

the other VES points. VES 25 will be preferable for groundwater development due to its relatively high overburden thickness and the delineation of a fracture basement. To correlate with the 2-D resistivity structures, we consider the information from 0-5m depth on the geo-electric section since the foundation will probably be within this zone. At 5m depth, the resistivity is relatively high which correlate with the 2-D resistivity structure image and proved that the area on the studied location is suitable for engineering structures (building).

**(2-D Resistivity Structure)**

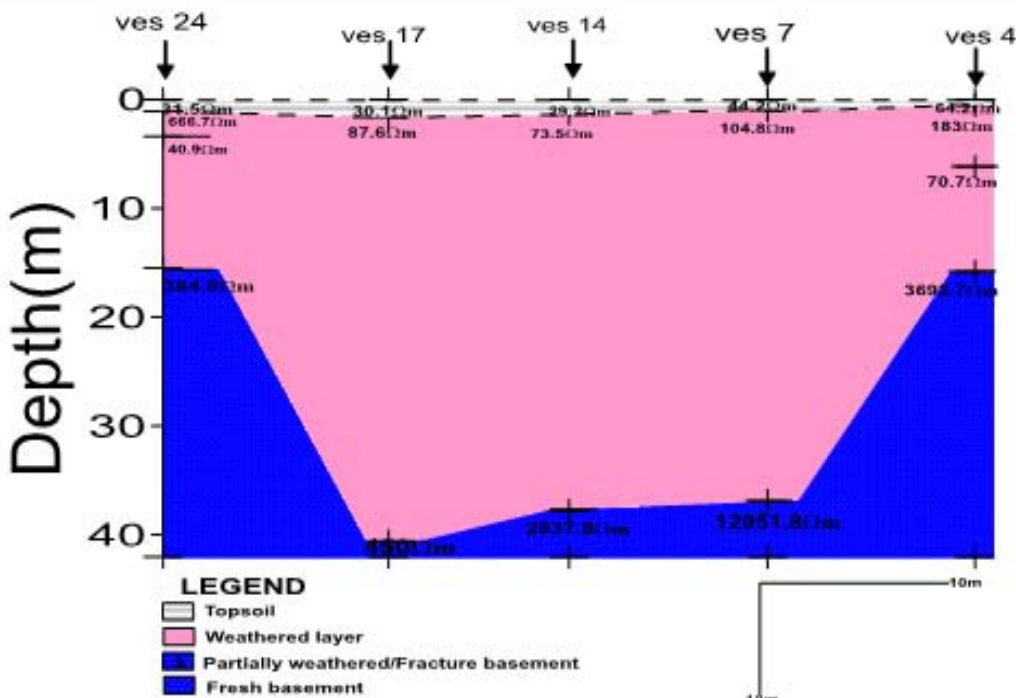
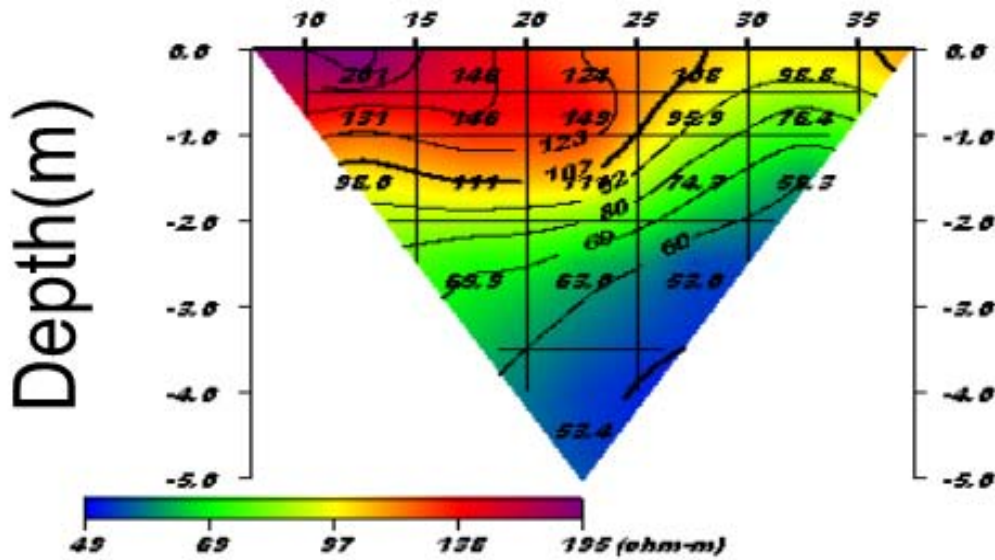

Figure 7: 2-D Resistivity Structures and Geo-Electric Section along Traverse 4

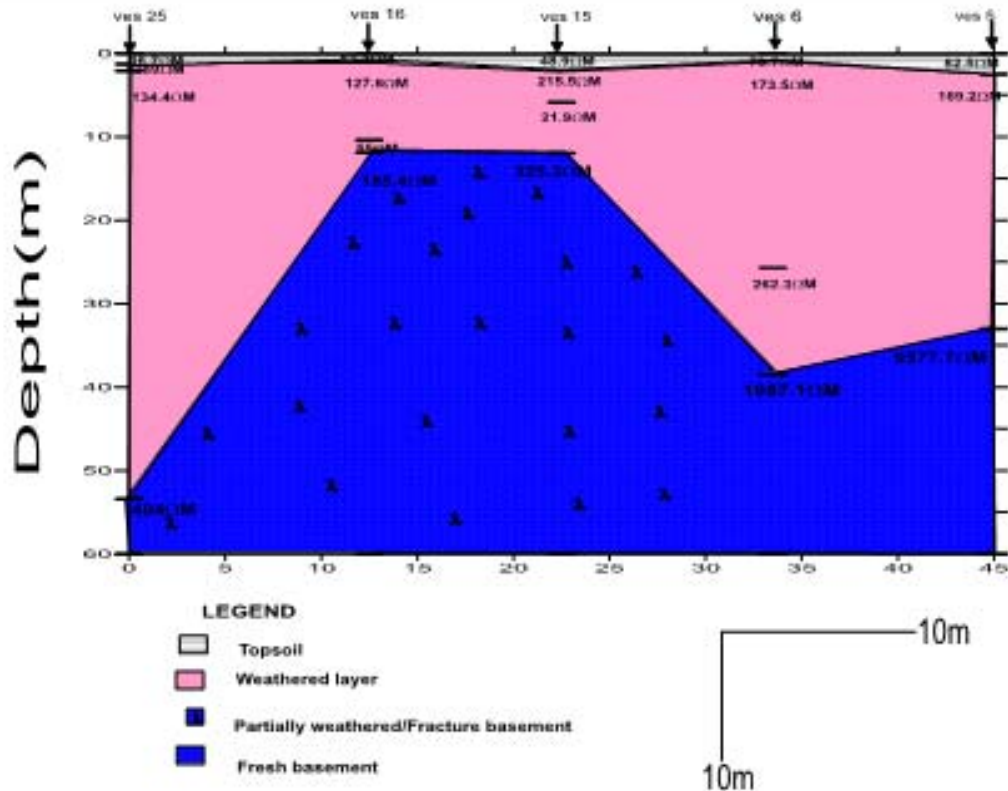
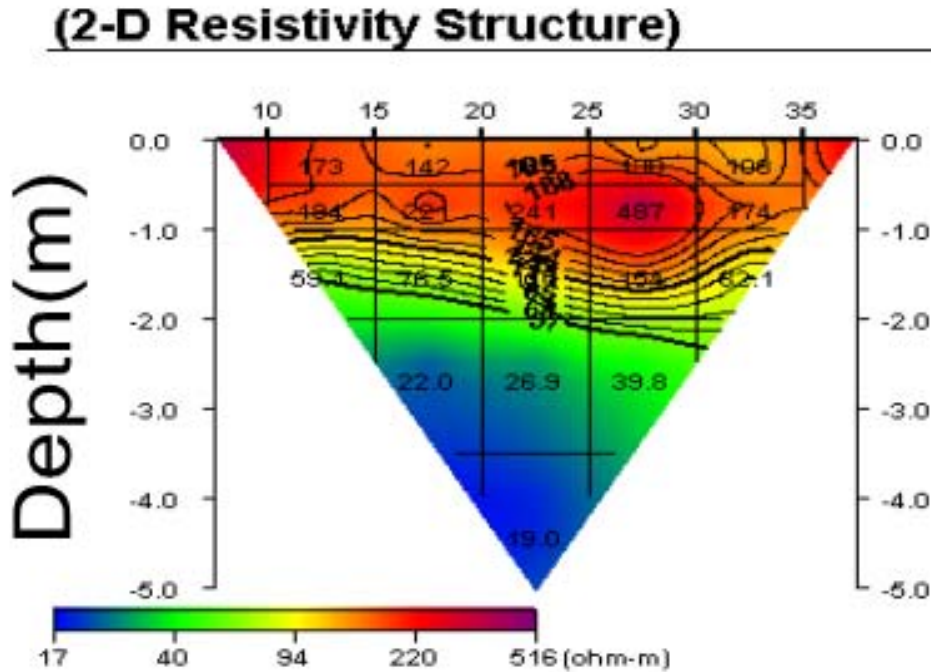

Figure 8: 2-D Resistivity Structures and Geo-Electric Section along Traverse 5

b) Sounding Curves

The curve type present in the area are KH, A, AKH, HK, HA. Curve type A is the dominant curve type occurring at about 50% of the studied location. Curve type KH having 32%. The summary of the geo-electric parameters are presented in Table 1.

c) Groundwater Potential of the Study Area

A total of 25 VES were occupied in the study location. Four (4) VES points namely VES 11, VES 13, VES 22 and VES 25 show good potential for groundwater development. VES 11 has relatively thick overburden and a partly weathered/fractured basement

zone was delineated. However, due to the fact that VES 11 lies at the area suitable for tank burial, the point was not recommended for groundwater development. VES 13 also is a good point for groundwater accumulation with similar characteristics with VES 11 but it is located at the center of the area which could be used for pump unit for sales point. VES 22 is also a suitable point for groundwater accumulation, however it is also located

along the possible exit route. VES 25 is the perfect location for possible groundwater development due to its relatively thick overburden, relatively low aquifer resistivity and a fractured basement. The location will also not obstruct zones suitable for building construction in the area. VES 25 has a KH curve type as shown in figure 9.

Table 1: Summary of VES Intepretation Results

VES NO	Resistivity (ohm – m)				Thickness (m)				Curve Types	
	$\rho_1$ $\rho_5$	$\rho_2$	$\rho_3$	$\rho_4$	$h_1$ $h_3$	$h_2$ $h_4$				
1	28.8	41.0	51.4	747.4	3.5	0.3	15.4		A	
2	25.5	163.5	12.3	863.7	0.6	1.0	5.4		KH	
3	39.9	79.3	599.8	8792.6	0.8	4.9	11.6		A	
4	64.2	183.0	70.7	33692.7	0.5	5.7	9.6		KH	
5	82.5	169.2	9577.7		2.5	30.6			A	
6	70.7	173.5	262.3	1987.1	0.8	24.8	12.9		A	
7	44.2	104.8	12951.8		1.0	35.8			A	
8	29.4	39.3	684.8		1.1	13.7			A	
9	21.9	27.8	361.0		1	12.4			A	
10	22.5	29.2	366.9		1.5	11.5			A	
11	25.8	18.1	63.7	479.9	0.7	4.7	28.1		HA	
12	20.8	28.4	2325.4		1.1	15.5			A	
13	28.8	27.5	105.4	86.6	1.7	1.4	23.0		HK	
14	29.2	73.5	2837.8		1.3	36.6			A	
15	48.9	215.5	21.9	325.3	1.9	4.1	6.0		KH	
16	53.3	127.6	55	185.4	0.7	9.7	1.6		KH	
17	30.1	87.6	450		1.6	39.6			A	
18	24.6	49.7	114.8		1.6	4.0			A	
19	27.5	62	497.4		2.2	35.5			A	
20	33.8	45.5	209.7	47.4	2.2	0.6	2.6	20.6	AKH	
21	21.7	254.5	415.2	96.8	2999.2	0.9	1.8	0.6	28.1	AKH
22	26.4	496.4	103.6	263.7		0.9	1.0	49.9		KH
23	31.8	257.1	35.9	231.1		2.1	4.2	12.3		KH
24	31.5	666.7	40.9	384.9		1.1	2.3	12.0		KH
25	46.7	438.9	134.4	404.0		1.3	0.8	51.3		KH

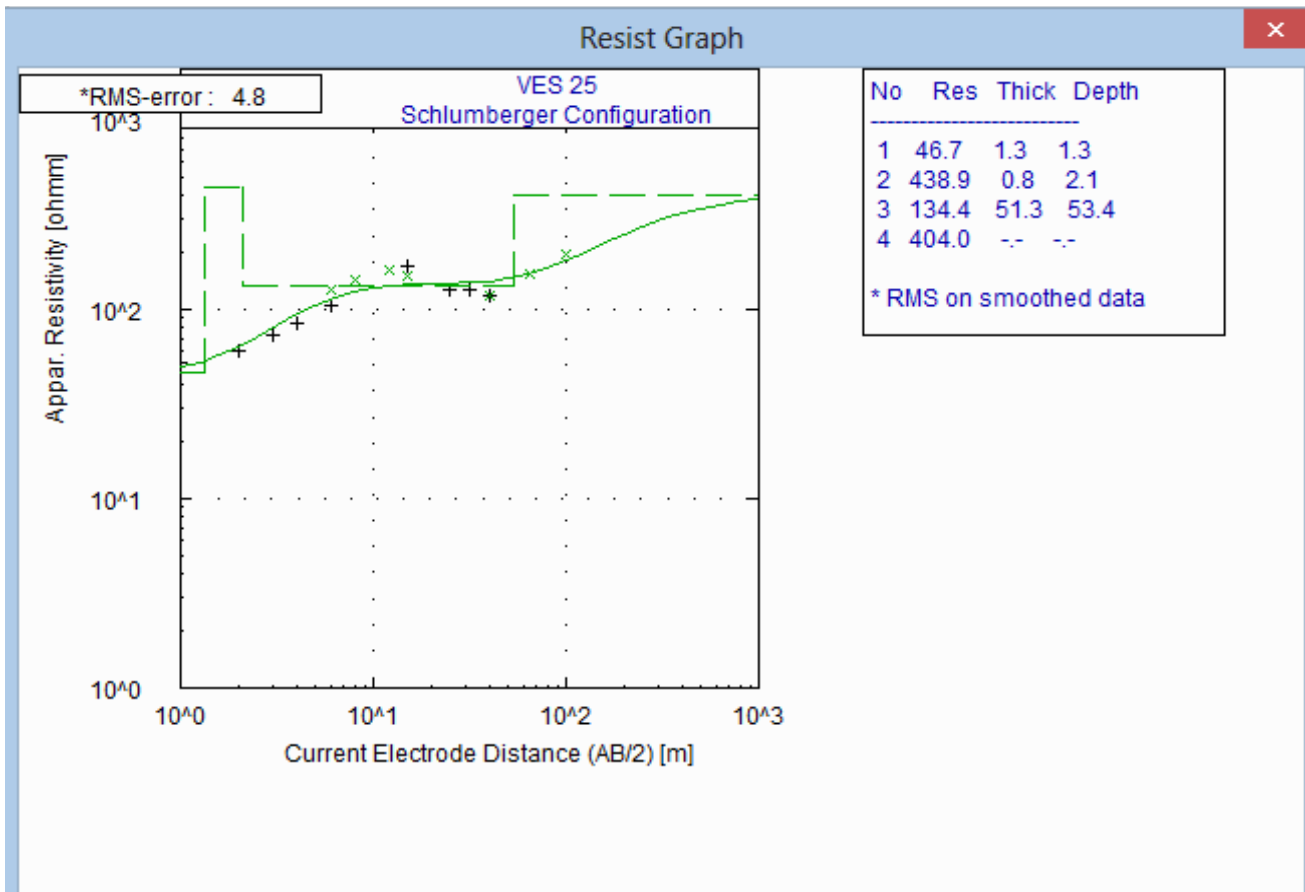

Figure 9: VES 25 With Typical KH Curve Type

d) Isoresistivity Map of the Study Area

Figure 10 shows the isoresistivity map of the second layer. The second layer was recognized as the area falling within the depth range suitable for shallow foundation within the study area. The area is predominantly characterized by low resistivity which is unfavorable to both engineering structure (buildings) and tank burial. Nevertheless, some area display relatively high resistivity which can sustain these structures. Relatively high resistivity in these area are in three (3) different locations around the north, northwest region and the last with relatively large area extent around edge of the east stretched down to the southeast edge of the area. These areas are going to be the suitable locations for the erection of buildings and also for the burial of tank. The borehole location as proposed by the VES is at the right top corner of the north east region. These information will guide in designing the model for the structural plan of the filling station.

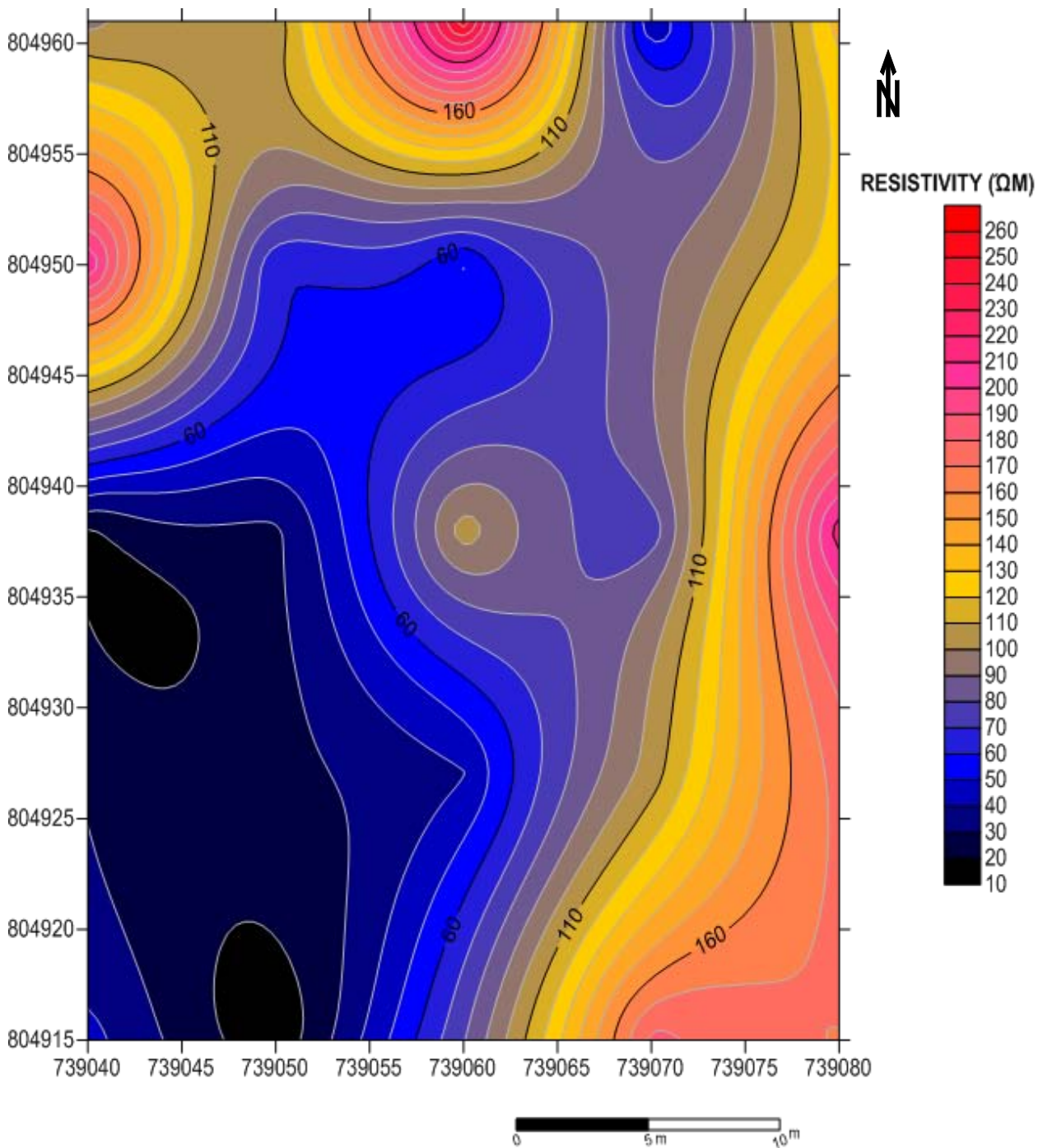

Figure 10: Isoresistivity Map of the Second Layer

e) Station Model

Due to the information obtained from the electrical resistivity survey and the isoresistivity map, Figure 11 shows the model and plan of the station. This will help tackle and minimize the threat or hazards that the filling station might face after development. The station has the tank burial point at the southwest location of the study area. This is due to the area being characterized by relatively high resistivity zone and thus resistant to corrosion. The petrol pump unit is

proposed towards the center of the study area, it has the area competent for building stretching from south east to north eastern part of the study area. The proposed location for groundwater development through borehole is at the extreme of the north eastern part of the study area. The kero unit is at the northern section while the diesel is at the western zone. The entry point is proposed to be at the southern section of the study area and finally exit point located at the north western part of the study area.

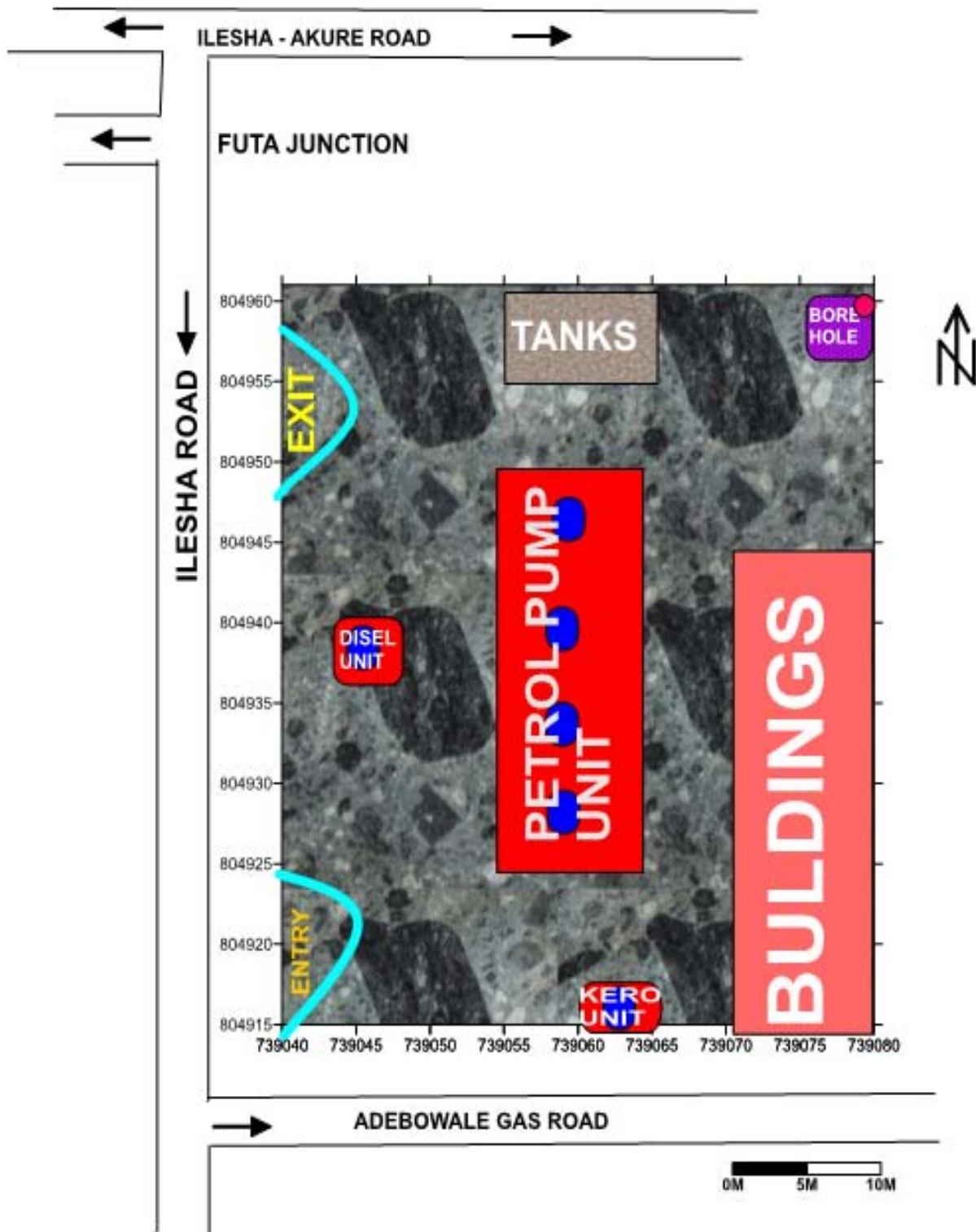

Figure 11: Model for the Proposed Filling Station

f) Conclusion

The usefulness of Electrical resistivity method in producing a model for a proposed filling station has been discussed. The subsurface characterization of the study area shows the heterogeneous nature of the subsurface particularly in a basement complex terrain. The study was able to delineate weathered layer and

fractured zones that are inimical to engineering works and also useful for groundwater development. Competent zones suitable for tank burial and erection of buildings were also delineated. This study has successfully brought to fore the relevance of geophysics particularly electrical resistivity method as an important tool in pre-construction studies. The study proffer



solution to environmental hazard such as contaminant plume and leachates into the groundwater system of the environment that might have occurred if the tank were to be buried within a porous and or permeable location. The study also assist in ascertaining the foundation integrity of the proposed structures in the study area.

## VI. ACKNOWLEDGEMENT

The authors acknowledge Mr Mamukuyomi, E.A for his assistance during the data acquisition.

## REFERENCES RÉFÉRENCES REFERENCIAS

1. Adelusi, A.O., Akinlalu, A.A. And Adebayo, S.S. (2013): Geophysical and Hydrochemistry Methods for Mapping Ground water Contamination around Aule Area, Akure, Southwestern Nigeria. *International Journal of Water Resources and Environmental Engineering*. Vol. 5(7), pp. 442-451.
2. Adelusi, A.O., Akinlalu, A.A. and Daramola, B.W. (2014): Integrated Geophysical Methods for Post Construction Studies: Case Study of Omuo Comprehensive High School, Omuo Ekiti, Southwestern, Nigeria. *Global Journal of Science Frontier Research (H)*. Volume XIV, Issue 1, Version 1. pp 31-41.
3. Adeyemo, I.A. and Omosuyi, G.O. (2012): Geophysical investigation of road pavement instability along part of Akure-Owo express way, Southwestern Nigeria. *American Journal of Scientific and Industrial Research*.
4. Al-Garni, Mansour Abdullah (2010): Magnetic survey for delineating subsurface structures and estimating magnetic sources depth, Wadi Fatima, KSA. *Journal of King Saud University (Science)* (2010) 22, 87-96.
5. Ayolabi, E.A., Adeoti, L., Oshinlaja, N.A., Adeosun, I.O. and Idowu, O.I. (2009): Seismic Refraction and Resistivity Studies of Part of Igbogbo Township, Southwestern Nigeria. *Journal of Sci. Res. Dev.*, Vol.11, pp 42-61.
6. Bale, R.B., Bayewu, O.O., Folorunso, I.O. and Oloruntola, M.O. (2010): Estimation of Reserve Overburden Ratio of a Proposed Quarry Site using Resistivity Survey: A Case Study of Ajebo near Abeokuta, Southwestern Nigeria. *World Applied Sciences Journal*, 10 (8), pp 963-971.
7. Balogun, O. Y. (2003): Senior Secondary School Atlas. Longman Publishers. 2<sup>nd</sup> Edition. 3<sup>rd</sup> Impression.
8. Bayode S., Omosuyi, G.O. and Abdullai, H.I. (2012): Post Foundation Engineering Geophysical Investigation in Part of the Federal University of Technology, Akure, Southwestern, Nigeria. *Journal of Emerging Trends in Engineering and Applied Sciences*. 3(1). pp 203-210.
9. Dippro for Windows (2000): Dippro™ Version 4.0 Processing and Interpretation software for Dipole – Dipole electrical resistivity data.KIGAM, Daejon, South Korea; 2000.
10. Eluyemi, A.A., Olorunfemi, M.O. and Ogunfolakan, M.A. (2012): Integrated Geophysical Investigation of Orile Oje Archaeological Sites, Ogbomoso, Southwestern Nigeria. *Pacific Journal of Science and Technology*. Volume 13(1). pp 615-630.
11. Owoyemi, F.B.(1996): A Geological-Geophysical Investigation of Rain-Induced Erosional Features in Akure Metropolis. Unpublished. M. Tech Thesis, Federal University of Technology: Akure, Nigeria, pp. 11-18.
12. Oyedele, K.F., Oladele, S. and Adedoyin, O. (2011): Application of Geophysical and Geotechnical Methods to Site Characterization for Construction Purposes at Ikoyi, Lagos, Nigeria. *Journal of Earth Sciences and Geotechnical Engineering*. Vol.1.no. 1.pp 87-100.
13. Patrax H.P, Nath S.K. (1998):Schlumberger geoelectric sounding in groundwater. Principles, Interpretation and Application. A. A. Balkema publishers, Brookfield. PP. 183.
14. Rahaman M.A (1976): Review of the Basement Geology of S-W Nigeria. in C.A. Kogbe, Elizabethan Publishing Company Lagos Nigeria 42-58.
15. Rahaman, M.A. (1989):Review of the basements geology of southwestern Nigeria. In Kogbe, C. A., (ed.) *Geology of Nigeria*, pp. 39-56.
16. Vander Velpen B.P.A (2004): Win RESIST Version 1.0 Resistivity Depth Sounding Interpretation Software. M. Sc Research Project, ITC, Delf Netherland.



# Bianchi Type VI Cosmological Model with Quadratic form of Time Dependent $\Lambda$ Term in General Relativity

By G. S. Khadekar, Shilpa Samdurkar & Shoma Sen

*RTM Nagpur University*

**Abstract-** In this paper, we obtained solution of Einstein field equations for Bianchi type VI cosmological model with time dependant cosmological term  $\Lambda$  of the form  $\Lambda = \frac{\alpha}{R^2} + \beta H^2$ ,  $\Lambda = \frac{\alpha}{R^2} + \beta H^2 + \gamma$  and  $\Lambda = \Lambda_0 + \Lambda_1 H + \Lambda_2 H^2$ . It is observed that cosmological term  $\Lambda$  is decreasing function of time which is consistent with results from recent supernova Ia observations. Also, it is noted that the model approaches to isotropy for  $n = 1$ . All the physical parameters are calculated and discussed.

**Keywords:** *bianchi type VI cosmological model • stiff fluid • cosmological term  $\Lambda$*

**GJSFR-A Classification:** *FOR Code: 240599p*



*Strictly as per the compliance and regulations of :*



# Bianchi Type VI Cosmological Model with Quadratic form of Time Dependent $\Lambda$ Term in General Relativity

G. S. Khadekar <sup>α</sup>, Shilpa Samdurkar <sup>σ</sup> & Shoma Sen <sup>ρ</sup>

**Abstract-** In this paper, we obtained solution of Einstein field equations for Bianchi type VI cosmological model with time dependant cosmological term  $\Lambda$  of the form  $\Lambda = \frac{\alpha}{R^2} + \beta H^2$ ,  $\Lambda = \frac{\alpha}{R^2} + \beta H^2 + \gamma$  and  $\Lambda = \Lambda_0 + \Lambda_1 H + \Lambda_2 H^2$ . It is observed that cosmological term  $\Lambda$  is decreasing function of time which is consistent with results from recent supernova Ia observations. Also, it is noted that the model approaches to isotropy for  $n = 1$ . All the physical parameters are calculated and discussed.

**Keywords:** bianchi type VI cosmological model • stiff fluid • cosmological term  $\Lambda$ .

## 1. INTRODUCTION

In the modern cosmological theories, one of the most theoretical parameter to calculate dark energy is cosmological constant (Weinberg [1], Sahni and Starobinsky [2], Peebles and Ratra [3]). The cosmological observations provide the existence of a positive cosmological constant with magnitude  $\Lambda \approx (\frac{Gh}{c^3}) = 10^{-123}$  by the High-Z Supernova Team and the Supernova Cosmological Project (Garnavich ([4], [5]), Perlmutter ([6], [7]), Riess [8], Schmidt [9]). It is found that there is a huge difference between observational and the particle physics prediction value for  $\Lambda$  which is known as cosmological constant problem. This dynamic cosmological term  $\Lambda(t)$  solves the cosmological constant problem in a natural way. There is significant observational evidence towards identifying Einsteins cosmological constant of the universe that varies slowly with time and space and so acts like.

It is observed that the dynamic  $\Lambda$  term decays with time (Gasperini ([10], [11]), Berman ([12], [13], [14]), Ozer and Taha [15], Freese [16], Peebles and Ratra [17], Chen and Wu [18], Abdussattar and Vishwakarma [19], Gariel and Le Dennat [20]). In the different context Berman ([12], [13], [14]), has argued in the favor of dependence  $\Lambda \propto \frac{1}{t^2}$ . The concept of decaying law helps to solve the cosmological problems very successfully. Further, the law of variation of scale

factor useful to solve the field equations was proposed by Pavon [21]. In earlier literature, the dynamical  $\Lambda$  term is proportional to scale factor have been studied by Holye et al. [22], Olson et al. [23], Maia et al. [24], Silveria et al. ([25], [26]), Torres et al. [27].

Chen and Wu [18] considered  $\Lambda \propto R^{-2}$  where  $R$  is the scale factor was generalized by Carvalho et al. [28] by considering  $\Lambda = \alpha R^{-2} + \beta H^2$  and later on by Waga [29] by considering  $\Lambda = \alpha R^{-2} + \beta H^2 + \gamma$  where  $\alpha$ ,  $\beta$  and  $\gamma$  are adjustable dimensionless parameters. Dwivedi and Tiwari [30] have investigated Bianchi Type V cosmological models with time varying  $G$  and by assuming the condition  $\Lambda = \frac{\beta}{R^2} + H^2$ . In cosmological models, stiff fluid creates more interest in the results. Barrow [31] has discussed the relevance of stiff equation of state  $\rho = p$  to the matter content of the universe in the early state of evolution of universe. Exact solution of Einsteins field equation with stiff equation of state has been investigated by Wesson [32].

At the early stages of evolution, the cosmological models play significant roles in the description of the universe. Bianchi I to IX spaces are very useful for constructing special homogeneous cosmological models. Homogeneous and anisotropic models have been widely studied in the frame work of general relativity by many authors viz. Wainwright et al. [33], Collins and Hawking [34], Ellis and MacCallum [35], Dunn and Tupper [36], MacCallum [37], Roy and Bali [38], Bali [39], Roy and Banerjee [40], Bali and Singh [41] to name only few. Raj Bali et al. [42] have studied Bianchi III cosmological model for barotropic fluid distribution with variable  $G$  and  $\Lambda$ . Singh and Beesham et al. [43] have investigated Bianchi V perfect fluid spacetime with variable  $G$  and  $\Lambda$ . Bianchi type V universe with bulk viscous matter and time varying gravitational and cosmological model have been studied by Baghel and Singh [44]. Saha et al. [45] have investigated Bianchi I cosmological model with time dependant gravitational and cosmological constants: An alternative approach. Singh et al. [46] have discussed bulk viscous anisotropic cosmological model with dynamical cosmological parameters  $G$  and  $\Lambda$ . Bianchi type V cosmological model with varying cosmological term have been studied by Tiwari and Singh [47].

Barrow [48] has pointed out that the Bianchi Type  $VI_0$  cosmological models give a better explanation

**Author  $\alpha$ :** Dept. of Mathematics, Rashtrasant Tukadoji Maharaj Nagpur University, Mahatma Jyotiba, Phule Educational Campus, Amravati Road, Nagpur, India. e-mail: gkhadekar@yahoo.com

**Author  $\sigma$ :** Dept. of Mathematics, Vidya Vikas Arts Commerce and Science College, Samudrapur, Dist. Wardha, India. e-mail: rpahade2008@rediffmail.com

**Author  $\rho$ :** Dept. of Applied Mathematics, Priyadarshini Institute of Engineering and Technology, Hingna Road, Nagpur, India. e-mail: shomasen0808@gmail.com

of some of cosmological problems like primordial helium abundance and these models isotropize in special case. Chandell et al. [49] have discussed Bianchi Type  $V I_0$  dark energy cosmological model in general relativity. Mishra et al. [50] have studied five dimensional Bianchi Type  $V I_0$  dark energy cosmological model in general relativity. Accelerating dark energy models with anisotropic fluid in Bianchi type  $V I_0$  space time has been discussed by Anirudh Pradhan [51]. Saha [52] have discussed Bianchi Type VI anisotropic dark energy model with varying EoS parameter. Verma and Shri Ram [53] have studied Bianchi type  $V I_0$  bulk viscous fluid models with variable gravitational and cosmological constants. Stability of viscous fluid in Bianchi type VI model with cosmological constant have been discussed by Sadeghi et al. [54]. Singh et al. [55] have discussed Bianchi Type  $V I_0$  viscous fluid cosmological models with time-dependent cosmological term  $\Lambda$ .

One of the motivations for introducing  $\Lambda$  term is to reconcile the age parameter and the density parameter of the universe with recent observational data. In this paper, we have discussed Bianchi type VI cosmological models with varying cosmological term  $\Lambda$  in the presence of stiff fluid. We have obtained the solutions of Einstein field equations for three different cases i.e case (i):  $\Lambda = \frac{\alpha}{R^2} + \beta H^2$ , case (ii):  $\Lambda = \frac{\alpha}{R^2} + \beta H^2 + \gamma$  and case (iii):  $\Lambda = \Lambda_0 + \Lambda_1 H + \Lambda_2 H^2$  by assuming the expansion  $\theta$  is proportional to shear  $\sigma$  which leads to the condition between metric potential  $A = B^n$ .

## II. METRIC AND FIELD EQUATIONS

The spatially homogeneous and anisotropic Bianchi type VI spacetime is described by the line element

$$ds^2 = -dt^2 + A^2 dx^2 + B^2 e^{-2x} dy^2 + C^2 e^{2x} dz^2, \quad (1)$$

where  $A$ ,  $B$  and  $C$  are functions of time  $t$  only.

We assume that cosmic matter is a perfect fluid given by energy momentum tensor

$$T_{ij} = (\rho + p)u_i u_j + p g_{ij}, \quad (2)$$

satisfying equation of state (EoS)

$$p = \omega \rho, \quad 0 \leq \omega \leq 1, \quad (3)$$

where  $\rho$  being the matter density,  $p$  the isotropic pressure,  $u^i$  the flow vector of the fluid satisfying  $u_i u^i = -1$ .

Einstein field equations with time varying cosmological term  $\Lambda$  is given by

$$R_{ij} - \frac{1}{2} R g_{ij} = -8\pi G T_{ij} + \Lambda g_{ij}. \quad (4)$$

For the metric (1) and energy momentum tensor (2) in co-moving system of co-ordinates, the field equations (4) yields

$$\frac{\dot{A}\dot{B}}{AB} + \frac{\dot{B}\dot{C}}{BC} + \frac{\dot{A}\dot{C}}{AC} - \frac{1}{A^2} = 8\pi G \rho + \Lambda, \quad (5)$$

$$\frac{\ddot{B}}{B} + \frac{\ddot{C}}{C} + \frac{\dot{B}\dot{C}}{BC} + \frac{1}{A^2} = -8\pi G p + \Lambda, \quad (6)$$

$$\frac{\ddot{A}}{A} + \frac{\ddot{C}}{C} + \frac{\dot{A}\dot{C}}{AC} - \frac{1}{A^2} = -8\pi G p + \Lambda, \quad (7)$$

$$\frac{\ddot{A}}{A} + \frac{\ddot{B}}{B} + \frac{\dot{A}\dot{B}}{AB} - \frac{1}{A^2} = -8\pi G p + \Lambda, \quad (8)$$

$$\frac{\dot{B}}{B} - \frac{\dot{C}}{C} = 0. \quad (9)$$

Last equation gives

$$B = C. \quad (10)$$

Then field equations (5) -(8) can be written as,

$$2\frac{\dot{A}\dot{B}}{AB} + \frac{\dot{B}^2}{B^2} - \frac{1}{A^2} = 8\pi G \rho + \Lambda, \quad (11)$$

$$2\frac{\ddot{B}}{B} + \frac{\dot{B}^2}{B^2} + \frac{1}{A^2} = -8\pi G p + \Lambda, \quad (12)$$

$$\frac{\ddot{A}}{A} + \frac{\ddot{B}}{B} + \frac{\dot{A}\dot{B}}{AB} - \frac{1}{A^2} = -8\pi G p + \Lambda. \quad (13)$$

Taking into account the conservation equation  $div(T_i^j) = 0$ , we have

$$8\pi \dot{G} \rho + 8\pi G \dot{\rho} + 8\pi G (\rho + p) \left( \frac{\dot{A}}{A} + 2\frac{\dot{B}}{B} \right) - \dot{\Lambda} = 0, \quad (14)$$

which leads to

$$8\pi \dot{G} \rho - \dot{\Lambda} = 0, \quad (15)$$

$$\dot{\rho} + (\rho + p) \left( \frac{\dot{A}}{A} + 2\frac{\dot{B}}{B} \right) = 0. \quad (16)$$

We define the average scale factor  $R$  and generalized Hubble parameter  $H$  for Bianchi VI universe as

$$V = R^3 = ABC = AB^2, \quad (17)$$

$$H = \frac{\dot{R}}{R} = \frac{1}{3}(H_1 + H_2 + H_3). \quad (18)$$

Adding (11) and (12) with the use of (3), we get,

$$\frac{\ddot{B}}{B} + \frac{\dot{A}\dot{B}}{AB} + \frac{\dot{B}^2}{B^2} = 4\pi G (1 - \omega) \rho + \Lambda. \quad (19)$$

We assume that the expansion  $\theta$  is proportional to the shear  $\sigma$ . This condition leads to,

$$A = B^n. \quad (20)$$

Then field equations (11)-(13) can be written as,

$$(2n + 1) \frac{\dot{B}^2}{B^2} - \frac{1}{B^{2n}} = 8\pi G \rho + \Lambda, \quad (21)$$

$$2\frac{\ddot{B}}{B} + \frac{\dot{B}^2}{B^2} + \frac{1}{B^{2n}} = -8\pi Gp + \Lambda, \quad (22)$$

$$(n+1)\frac{\ddot{B}}{B} + n^2\frac{\dot{B}^2}{B^2} - \frac{1}{B^{2n}} = -8\pi Gp + \Lambda. \quad (23)$$

With the use of (20), for  $\omega = 1$ , Eq. (19) can be written as,

$$\frac{\ddot{B}}{B} + (n+1)\frac{\dot{B}^2}{B^2} = \Lambda. \quad (24)$$

a) Case (i):

We assume the cosmological term in the form

$$\Lambda = \frac{\alpha}{R^2} + \beta H^2. \quad (25)$$

Solving (24) with the use of (25), we get,

$$B\ddot{B} + \alpha_1\dot{B}^2 = \frac{\alpha}{B^{\frac{2(n-1)}{3}}}, \quad (26)$$

where  $\alpha_1 = (n+1) - \frac{\beta(n+2)^2}{9}$ .

Solving we get,

$$\dot{B}^2 = \frac{9\alpha}{(n+2)[6-\beta(n+2)]} \frac{1}{B^{\frac{2(n-1)}{3}}} + \frac{k_1}{B^{2\alpha_1}}. \quad (27)$$

where  $k_1$  is integration constant.

Integrating, we get

$$\int \frac{B^{\frac{b}{2}} dB}{\sqrt{k_1 + DB^{b-a}}} = \int dt + k_2, \quad (28)$$

where  $k_2$  is integration constant,

$$a = \frac{2(n-1)}{3}, \quad b = 2(n+1) - \frac{2\beta(n+2)^2}{9}, \quad D = \frac{9\alpha}{(n+2)[6-\beta(n+2)]}.$$

To solve Eq. (28), we assume that  $n \neq 1$ ,  $a = b$  then we get,

$$\int B^{\frac{b}{2}} dB = D_0 \left( \int dt + k_2 \right), \quad (29)$$

where  $D_0 = \sqrt{k_1 + D}$ .

Solving, we get,

$$B = \left[ \frac{(n+2)D_0(t+k_2)}{3} \right]^{\frac{3}{n+2}}, \quad (30)$$

$$A = \left[ \frac{(n+2)D_0(t+k_2)}{3} \right]^{\frac{3n}{n+2}}. \quad (31)$$

The metric (1) reduces to,

$$ds^2 = -dt^2 + \left[ \frac{(n+2)D_0(t+k_2)}{3} \right]^{\frac{6n}{n+2}} dx^2 + \left[ \frac{(n+2)D_0(t+k_2)}{3} \right]^{\frac{6}{n+2}} (e^{-2x} dy^2 + e^{2x} dz^2). \quad (32)$$

b) Some physical and geometrical aspects of the model

The energy density  $\rho$ , pressure  $p$ , cosmological parameter  $\Lambda$ , gravitational parameter  $G$ , expansion scalar  $\theta$ , Hubble parameter  $H$ , spatial volume  $V$  are given by,

$$\rho = p = \frac{k_3}{\left[ \frac{(n+2)D_0(t+k_2)}{3} \right]^{2(n+2)}}, \quad (33)$$

$$\Lambda = \left[ \frac{9\alpha + (n+2)^2 \beta D_0^2}{9(n+2)^2 D_0^2} \right] \frac{1}{(t+k_2)^2}, \quad (34)$$

$$8\pi G = \left[ \frac{9(2n+1) - \beta(n+2)^2 - 9\alpha}{9k_3} \right] \left[ \frac{(n+2)D_0(t+k_2)}{3} \right]^4 - \frac{1}{k_3} \left[ \frac{(n+2)D_0(t+k_2)}{3} \right]^{\frac{12}{n+2}}, \quad (35)$$

$$\theta = \frac{3}{(t+k_2)}, \quad \sigma^2 = \frac{3(n-1)^2}{(n+2)^2} \frac{1}{(t+k_2)^2}, \quad (36)$$

$$H = \frac{1}{(t+k_2)}, \quad V = \left[ \frac{(n+2)D_0(t+k_2)}{3} \right]^3. \quad (37)$$

For  $n = 1$ ,  $\beta = \frac{5}{2}$ , we get

$$A = B = l_1 t^2 + l_2 t + l_3, \quad (38)$$

where  $l_1 = \frac{k_1}{4}$ ,  $l_2 = \frac{k_1 k_2}{2}$ ,  $l_3 = \left( \frac{k_1 k_2^2}{4} + \frac{2\alpha}{k_1} \right)$ .

The metric (1) reduces to,

$$ds^2 = -dt^2 + (l_1 t^2 + l_2 t + l_3)^2 (dx^2 + e^{-2x} dy^2 + e^{2x} dz^2). \quad (39)$$

and accordingly get the values of energy density, pressure  $p$ , cosmological parameter  $\Lambda$ , gravitational parameter  $G$ , expansion scalar  $\theta$ , Hubble parameter  $H$ , spatial volume  $V$  which are similar to the values obtained as given by Eq. (33) to Eq. (37) by putting  $n = 1$ . For this case we get the isotropic model.

c) Case (ii):

We assume a relation,

$$\Lambda = \frac{\alpha}{R^2} + \beta H^2 + \gamma. \quad (40)$$

Solving Eq. (24) with the use of (40), we get,

$$B\ddot{B} + \alpha_1\dot{B}^2 = \frac{\alpha}{B^{\frac{2(n-1)}{3}}} + \gamma B^2. \quad (41)$$

Solving above Eq. we get the first integral,

$$\dot{B}^2 = \frac{9\alpha}{(n+2)[6-\beta(n+2)]} \frac{1}{B^{\frac{2(n-1)}{3}}}$$

$$+ \frac{9\gamma}{(n+2)[6-\beta(n+2)]} B^2 + \frac{k_4}{B^{2\alpha_1}}. \quad (42)$$

where  $k_4$  is constant of integration.

To solve the above integration, we take  $k_4 = 0$  Eq. (42) can be written as,

$$\dot{B}^2 = \frac{9\alpha}{(n+2)[6-\beta(n+2)]} \frac{1}{B^{\frac{2(n-1)}{3}}} + \frac{9\gamma}{(n+2)[6-\beta(n+2)]} B^2. \quad (43)$$

Integrating, we get

$$\int \frac{dB}{B\sqrt{m+DB^{-(n+2)}}} = \int dt + k_5, \quad (44)$$

where  $k_5$  is constant of integration,

$$a = \frac{2(n-1)}{3}, \quad D = \frac{9\alpha}{(n+2)[6-\beta(n+2)]}, \quad m = \frac{9\gamma}{(n+2)[6-\beta(n+2)]}.$$

Solving Eq. (44), we get

$$B = \left\{ \sqrt{\frac{D}{m}} \sinh \left[ \frac{(n+2)\sqrt{m}(t+k_5)}{3} \right] \right\}^{\frac{3}{n+2}}, \quad (45)$$

$$A = \left\{ \sqrt{\frac{D}{m}} \sinh \left[ \frac{(n+2)\sqrt{m}(t+k_5)}{3} \right] \right\}^{\frac{3n}{n+2}}. \quad (46)$$

The metric (1) reduces to,

$$ds^2 = -dt^2 + \left\{ \sqrt{\frac{D}{m}} \sinh \left[ \frac{(n+2)\sqrt{m}(t+C_4)}{3} \right] \right\}^{\frac{6n}{n+2}} dx^2 + \left\{ \sqrt{\frac{D}{m}} \sinh \left[ \frac{(n+2)\sqrt{m}(t+k_5)}{3} \right] \right\}^{\frac{6}{n+2}} (e^{-2x} dy^2 + e^{2x} dz^2). \quad (47)$$

In this case, the energy density  $\rho$ , pressure  $p$ , cosmological parameter  $\Lambda$ , gravitational parameter  $G$ , expansion scalar  $\theta$ , Hubble parameter  $H$ , spatial volume  $V$  are given by,

$$\rho = p = \frac{k_3 m^3}{D^3} \operatorname{cosech}^6 \left[ \frac{(n+2)\sqrt{m}(t+k_5)}{3} \right], \quad (48)$$

$$\Lambda = \left[ \frac{[9\alpha + \beta(n+2)^2] m}{9D} \right] \operatorname{cosech}^2 \left[ \frac{(n+2)\sqrt{m}(t+k_5)}{3} \right] + \frac{\beta m (n+2)^2}{9} + \gamma, \quad (49)$$

$$8\pi G = \frac{1}{9k_3} \left[ \frac{9(2n+1) - \beta(n+2)^2}{9} \right] m \operatorname{coth}^2 \left[ \frac{(n+2)\sqrt{m}(t+k_5)}{3} \right]$$

$$\left\{ \sqrt{\frac{D}{m}} \sinh \left[ \frac{(n+2)\sqrt{m}(t+k_5)}{3} \right] \right\}^6$$

$$- \frac{1}{k_3} \left\{ \sqrt{\frac{D}{m}} \sinh \left[ \frac{(n+2)\sqrt{m}(t+k_5)}{3} \right] \right\}^{\frac{12}{n+2}}$$

$$- \frac{\alpha}{k_3} \left[ \left\{ \sqrt{\frac{D}{m}} \sinh \left[ \frac{(n+2)\sqrt{m}(t+k_5)}{3} \right] \right\}^{\frac{12}{n+2}} \right]^4, \quad (50)$$

$$\theta = (n+2)\sqrt{m} \left\{ \operatorname{coth} \left[ \frac{(n+2)\sqrt{m}(t+k_5)}{3} \right] \right\}, \quad (51)$$

$$\sigma^2 = \frac{(n-1)^2}{3} m \operatorname{coth}^2 \left[ \frac{(n+2)\sqrt{m}(t+k_5)}{3} \right], \quad (52)$$

$$\frac{\sigma}{\theta} = \frac{(n-1)}{\sqrt{3}(n+2)} = \text{constant}, \quad (53)$$

$$H = \frac{(n+2)}{3} \sqrt{m} \operatorname{coth} \left[ \frac{(n+2)\sqrt{m}(t+k_5)}{3} \right], \quad (54)$$

$$V = \left\{ \sqrt{\frac{D}{m}} \sinh \left[ \frac{(n+2)\sqrt{m}(t+k_5)}{3} \right] \right\}^3. \quad (55)$$

d) Case (iii):

We assume a relation,

$$\Lambda = \Lambda_0 + \Lambda_1 H + \Lambda_2 H^2. \quad (56)$$

Solving Eq. (24) with the use of (56), we get,

$$\frac{\ddot{B}}{B} - L_1 \frac{\dot{B}^2}{B^2} - L_2 \frac{\dot{B}}{B} = L_3, \quad (57)$$

where  $L_1 = \frac{A_2(n+2)^2}{9} - (n+1)$ ,  $L_2 = \frac{A_1(n+2)}{3}$ ,  $L_3 = \Lambda_0$ .

Solving, we get,

$$B = k_7 \exp \left[ \frac{-L_2 t}{2(L_1 - 1)} \right] \left[ \sec \left( \frac{L_4}{2} (k_6 + t) \right) \right]^{\frac{1}{L_1 - 1}}, \quad (58)$$

$$A = \left[ k_7 \exp \left[ \frac{-L_2 t}{2(L_1 - 1)} \right] \left[ \sec \left( \frac{L_4}{2} (k_6 + t) \right) \right]^{\frac{1}{L_1 - 1}} \right]^n. \quad (59)$$

where  $L_4 = \sqrt{4(L_1 - 1)L_3 - L_2^2}$ ,  $k_6$  and  $k_7$  are constants of integration.

The metric (1) reduces to,

$$ds^2 = -dt^2 + \left[ k_7 \exp \left[ \frac{-L_2 t}{2(L_1 - 1)} \right] \left[ \sec \left( \frac{L_4}{2} (k_6 + t) \right) \right]^{\frac{1}{L_1 - 1}} \right]^{2n} dx^2 + \left[ k_7 \exp \left[ \frac{-L_2 t}{2(L_1 - 1)} \right] \left[ \sec \left( \frac{L_4}{2} (k_6 + t) \right) \right]^{\frac{1}{L_1 - 1}} \right]^2 (e^{-2x} dy^2 + e^{2x} dz^2). \tag{60}$$

In this case, the physical parameters are given by,

$$\rho = p = k_3 \left[ \frac{1}{k_7} \exp \left[ \frac{L_2 t}{2(L_1 - 1)} \right] \left[ \cos \left( \frac{L_4}{2} (k_6 + t) \right) \right]^{\frac{1}{L_1 - 1}} \right]^{2(n+2)}, \tag{61}$$

$$\Lambda = \Lambda_0 + \frac{A_1(n+2)}{6(L_1 - 1)} \left[ L_4 \tan \left( \frac{L_4}{2} (k_6 + t) \right) - L_2 \right] + \frac{A_2(n+2)^2}{36(L_1 - 1)^2} \left[ L_4 \tan \left( \frac{L_4}{2} (k_6 + t) \right) - L_2 \right]^2, \tag{62}$$

$$8\pi G = \frac{1}{k_3} \left[ k_7 \exp \left[ \frac{-L_2 t}{2(L_1 - 1)} \right] \left[ \sec \left( \frac{L_4}{2} (k_6 + t) \right) \right]^{\frac{1}{L_1 - 1}} \right]^{2(n+2)} \{ L_5 \left[ L_4 \tan \left( \frac{L_4}{2} (k_6 + t) \right) - L_2 \right]^2 - L_6 \left[ L_4 \tan \left( \frac{L_4}{2} (k_6 + t) \right) - L_2 \right] - \left\{ \frac{1}{k_7} \exp \left[ \frac{L_2 t}{2(L_1 - 1)} \right] \left[ \cos \left( \frac{L_4}{2} (k_6 + t) \right) \right] \right\}^{2n} - \Lambda_0 \}, \tag{63}$$

where  $L_5 = \left[ (2n + 1) - \frac{A_2(n+2)^2}{9} \right] \frac{1}{4(L_1 - 1)^2}$ ,  $L_6 = \frac{A_1(n+2)}{6(L_1 - 1)}$ .

$$\theta = \frac{(n + 2)}{2(L_1 - 1)} \left[ L_4 \tan \left( \frac{L_4}{2} (k_6 + t) \right) - L_2 \right], \tag{64}$$

$$\sigma^2 = \frac{(n - 1)^2}{12(L_1 - 1)^2} \left[ L_4 \tan \left( \frac{L_4}{2} (k_6 + t) \right) - L_2 \right]^2, \tag{65}$$

$$\frac{\sigma}{\theta} = \frac{(n - 1)}{\sqrt{3}(n + 2)} = \text{constant}, \tag{66}$$

$$H = \frac{(n + 2)}{6(L_1 - 1)} \left[ L_4 \tan \left( \frac{L_4}{2} (k_6 + t) \right) - L_2 \right], \tag{67}$$

$$V = \left\{ k_7 \exp \left[ \frac{-L_2 t}{2(L_1 - 1)} \right] \left[ \sec \left( \frac{L_4}{2} (k_6 + t) \right) \right]^{\frac{1}{L_1 - 1}} \right\}^{(n+2)}. \tag{68}$$

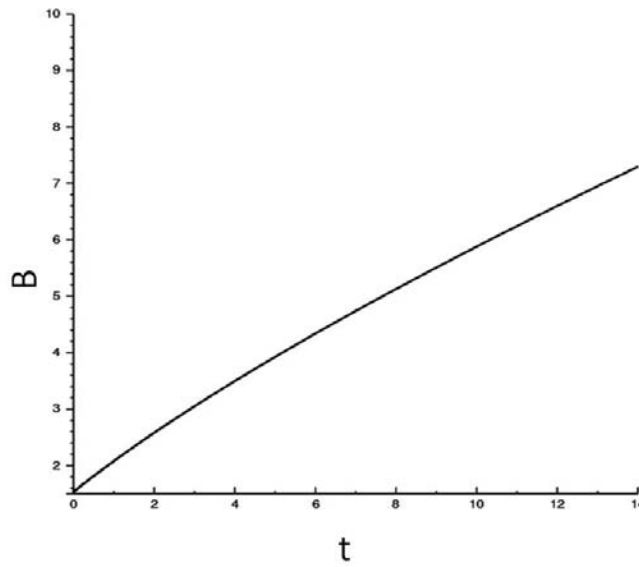

Fig. 1: Case (i)  $\Lambda = \frac{\alpha}{R^2} + \beta H^2$ ,  $n \neq 1$ ,  $a = b$ , Relation between  $B$  and time  $t$  for  $k_1 = 1$ ,  $k_2 = 2$ ,  $k_3 = 3$ ,  $n = 2$ ,  $\alpha = 1$ ,  $\beta = \frac{5}{2}$ ,  $D = -0.56$ ,  $D_0 = 0.6632$ .

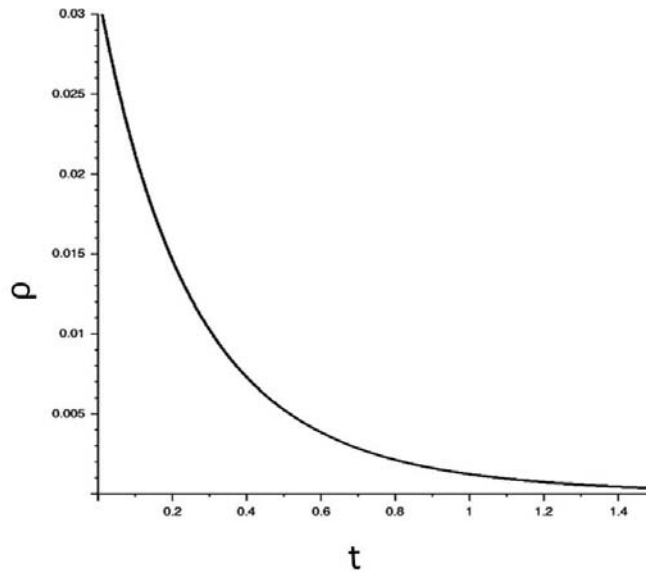

Fig. 2: Case (i)  $\Lambda = \frac{\alpha}{R^2} + \beta H^2$ ,  $n \neq 1$ ,  $a = b$ , Relation between  $\rho$  and time  $t$  for  $k_1 = 1$ ,  $k_2 = 2$ ,  $k_3 = 3$ ,  $n = 2$ ,  $\alpha = 1$ ,  $\beta = \frac{5}{2}$ ,  $D = -0.56$ ,  $D_0 = 0.6632$ .



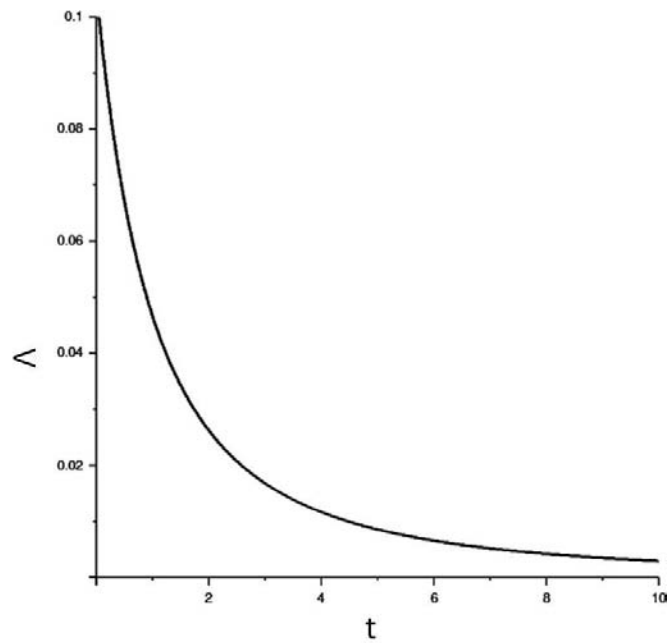

Fig. 3: Case (i)  $\Lambda = \frac{\alpha}{R^2} + \beta H^2$ ,  $n \neq 1$ ,  $a = b$ , Relation between  $\Lambda$  and time  $t$  for  $k_1 = 1, k_2 = 2, k_3 = 3, n = 2, \alpha = 1, \beta = \frac{5}{2}$ ,  $D = -0.56, D_0 = 0.6632$ .

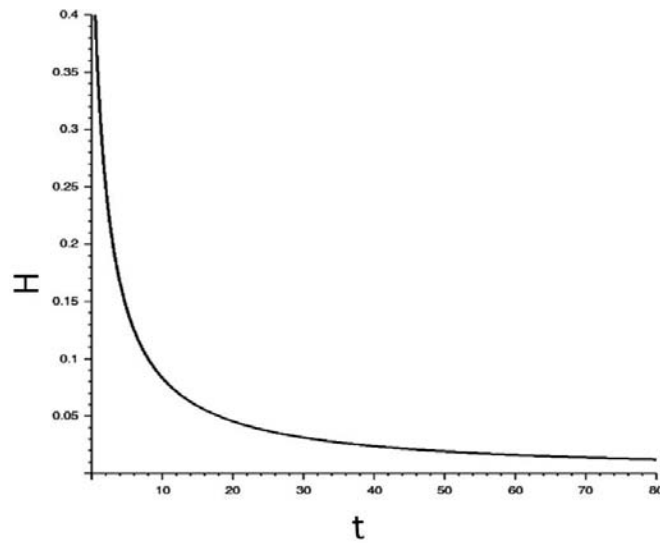

Fig. 4: Case (i)  $\Lambda = \frac{\alpha}{R^2} + \beta H^2$ ,  $n \neq 1$ ,  $a = b$ , Relation between  $H$  and time  $t$  for  $k_1 = 1, k_2 = 2, k_3 = 3, n = 2, \alpha = 1, \beta = \frac{5}{2}$ ,  $D = -0.56, D_0 = 0.6632$ .

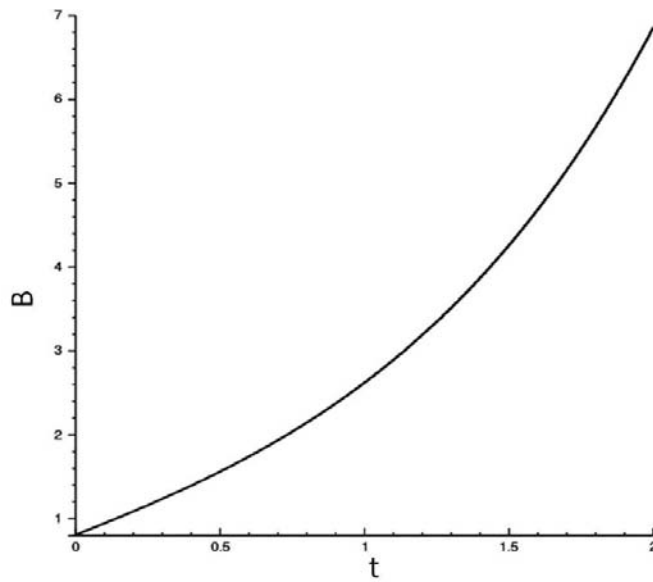

Fig. 5: Case (ii)  $\Lambda = \frac{\alpha}{R^2} + \beta H^2 + \gamma$ , Relation between  $B$  and time  $t$  for  $k_3 = 3, k_5 = 0.5, n = 2, \alpha = 1, \beta = 1, \gamma = 2, D = 1.125, m = 0.9$ .

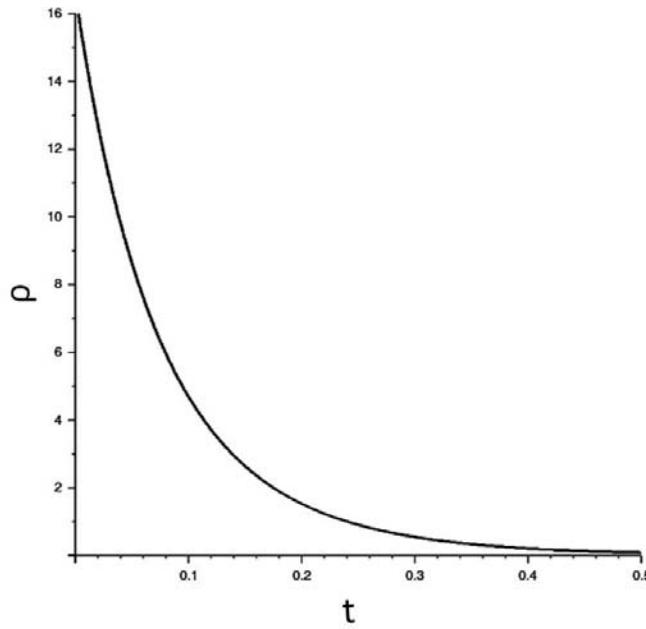

Fig. 6: Case (ii)  $\Lambda = \frac{\alpha}{R^2} + \beta H^2 + \gamma$ , Relation between  $\rho$  and time  $t$  for  $k_3 = 3, k_5 = 0.5, n = 2, \alpha = 1, \beta = 1, \gamma = 2, D = 1.125, m = 0.9$ .

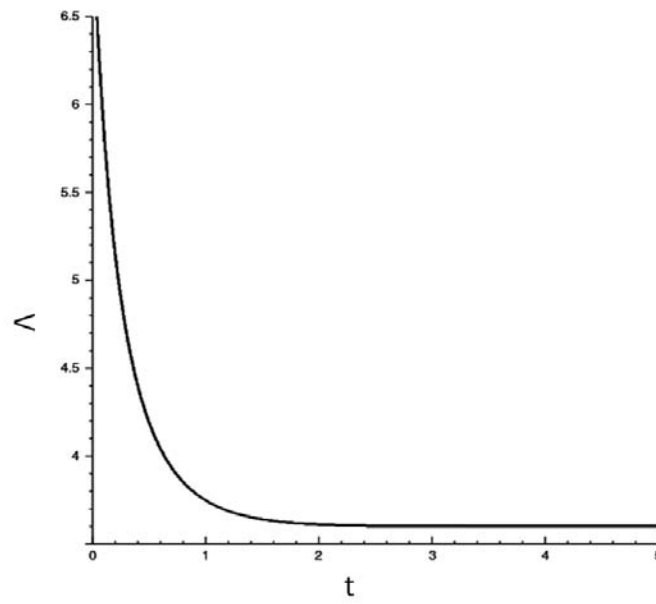

Fig. 7: Case (ii)  $\Lambda = \frac{\alpha}{R^2} + \beta H^2 + \gamma$ , Relation between  $\Lambda$  and time  $t$  for  $k_3 = 3, k_5 = 0.5, n = 2, \alpha = 1, \beta = 1, \gamma = 2, D = 1.125, m = 0.9$ .

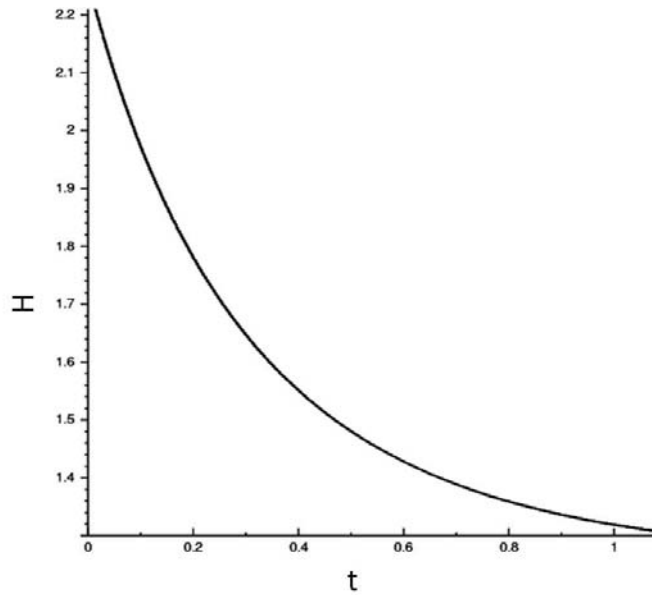

Fig. 8: Case (ii)  $\Lambda = \frac{\alpha}{R^2} + \beta H^2 + \gamma$ , Relation between  $H$  and time  $t$  for  $k_3 = 3, k_5 = 0.5, n = 2, \alpha = 1, \beta = 1, \gamma = 2, D = 1.125, m = 0.9$ .



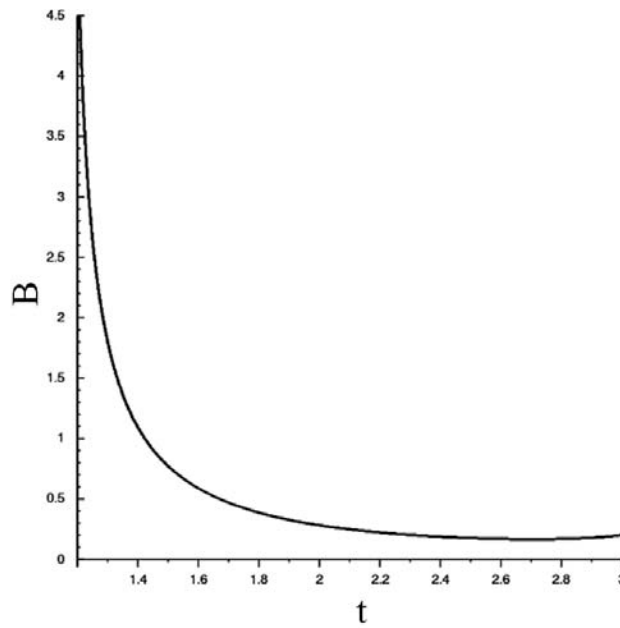

Fig. 9: Case (iii)  $\Lambda = \Lambda_0 + \Lambda_1 H + \Lambda_2 H^2$ , Relation between  $B$  and time  $t$  for  $k_3 = 3, k_6 = 2, k_7 = 2, n = 2, \Lambda_0 = 3, \Lambda_1 = 2, \Lambda_2 = 3, L_1 = 2.33, L_2 = 2.66, L_3 = 3, L_4 = 2.98$ .

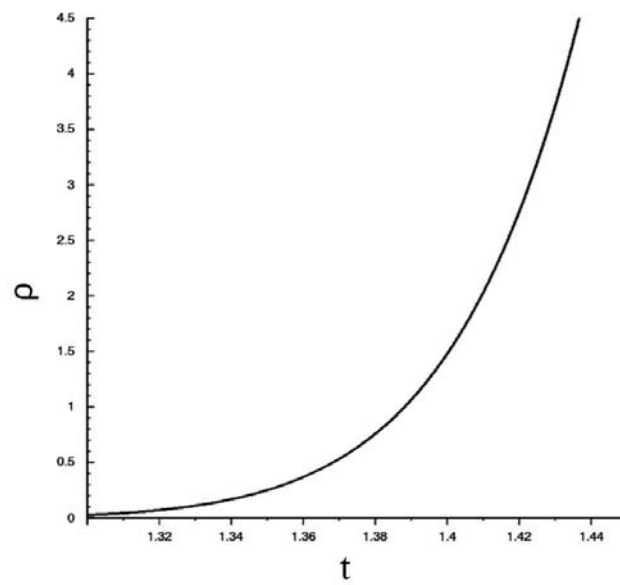

Fig. 10: Case (iii)  $\Lambda = \Lambda_0 + \Lambda_1 H + \Lambda_2 H^2$ , Relation between  $\rho$  and time  $t$  for  $k_3 = 3, k_6 = 2, k_7 = 2, n = 2, \Lambda_0 = 3, \Lambda_1 = 2, \Lambda_2 = 3, L_1 = 2.33, L_2 = 2.66, L_3 = 3, L_4 = 2.98$ .



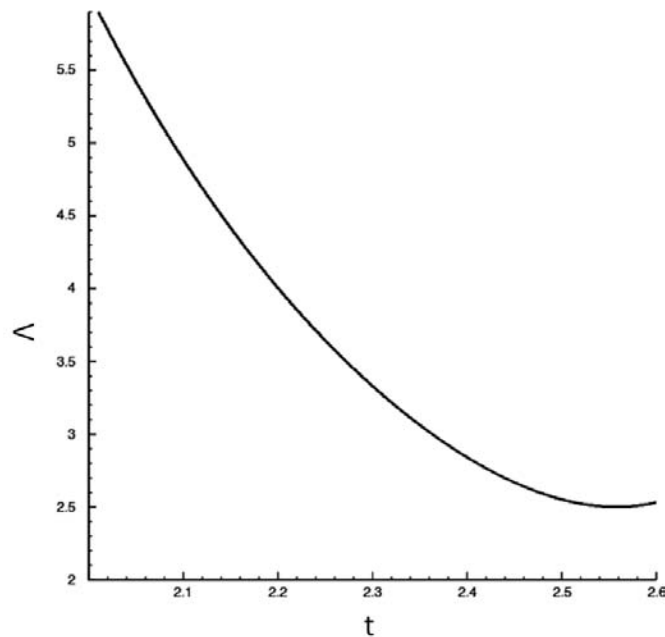

Fig. 11: Case (iii)  $\Lambda = \Lambda_0 + \Lambda_1 H + \Lambda_2 H^2$ , Relation between  $\Lambda$  and time  $t$  for  $k_3 = 3, k_6 = 2, k_7 = 2, n = 2, \Lambda_0 = 3, \Lambda_1 = 2, \Lambda_2 = 3, L_1 = 2.33, L_2 = 2.66, L_3 = 3, L_4 = 2.98$ .

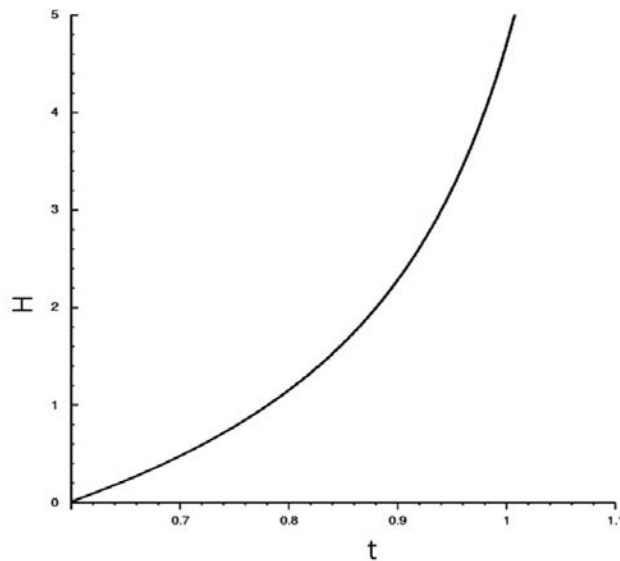

Fig. 12: Case (iii)  $\Lambda = \Lambda_0 + \Lambda_1 H + \Lambda_2 H^2$ , Relation between  $H$  and time  $t$  for  $k_3 = 3, k_6 = 2, k_7 = 2, n = 2, \Lambda_0 = 3, \Lambda_1 = 2, \Lambda_2 = 3, L_1 = 2.33, L_2 = 2.66, L_3 = 3, L_4 = 2.98$ .

Our findings: Here, we have obtained solutions of the Einstein field equations for three cases:

Case (i):  $\Lambda = \frac{\alpha}{R^2} + \beta H^2$

- it is seen that as  $t \rightarrow 0, V \rightarrow 0$  and as  $t \rightarrow \infty, V \rightarrow \infty$ .
- When  $t \rightarrow 0$ , the expansion scalar  $\theta$  and  $\rho$  tends to infinity and when  $t \rightarrow \infty$  the expansion scalar  $\theta$  and  $\rho$  tends to zero.
- Here,  $\frac{\sigma}{\theta} = \text{constant}$ .
- For  $\alpha > 0$ , it is observed that cosmological term  $\Lambda$  is decreasing function of time and approaches a small positive value at late time and for  $\alpha < 0$ , cosmological term  $\Lambda$  becomes positive.

- For  $n = 1$ , the model becomes isotropic.
- To illustrate the graph, we observe that the scale factor  $B(t)$  with respect to cosmic time  $t$  grows rapidly as shown in fig (1). Also from fig (2) to fig (4) we observe that the energy density  $\rho$ , cosmological term  $\Lambda$  and hubble parameter  $H$  goes on decreasing as time increases while they all become infinitely large as  $t$  approaches zero.

Case (ii):  $\Lambda = \frac{\alpha}{R^2} + \beta H^2 + \gamma$

- By taking suitable values of constant, it is observed that  $\rho, \Lambda, \theta, \sigma$  and  $H$  are all infinite and at late time they become zero for  $n > 1$ .
- It is observed that  $\frac{\sigma}{\theta} \neq 0$ .

- Also, for  $t \rightarrow 0, V \rightarrow 0$  and for  $t \rightarrow \infty, V \rightarrow \infty$ .
- Also, for  $t \rightarrow 0, V \rightarrow 0$  and for  $t \rightarrow \infty, V \rightarrow \infty$ .
- In this case, we observe that the scale factor  $B(t)$  with respect to cosmic time  $t$  grows rapidly as shown in fig (5). Also from fig (6) to fig (8) we observe that the energy density  $\rho$ , cosmological term  $\Lambda$  and hubble parameter  $H$  decreases with time  $t$  and approaches zero as  $t \rightarrow \infty$ .

Case (iii):  $\Lambda = \Lambda_0 + \Lambda_1 H + \Lambda_2 H^2$

- In this case also, the energy condition  $\rho \geq 0$  is satisfied.
- Also, the scale of expansion ( $\theta$ ) is infinite at  $t = 0$  and  $\theta$  becomes zero when  $t \rightarrow \infty$ .
- It is seen that  $\frac{\sigma}{\theta} = \text{constant}$ .
- Cosmological term  $\Lambda$  is decreasing function of time.
- We observe that the scale factor  $B(t)$  and energy density  $\rho$  with respect to cosmic time  $t$  grows rapidly as shown in fig (9) and fig (10). Also from fig (11) and fig (12) cosmological term  $\Lambda$  and hubble parameter  $H$  decreases with time  $t$  and approaches zero as  $t \rightarrow \infty$ .

### III. DISCUSSION AND CONCLUSION

- In this paper, we have investigated the role of  $\Lambda$  term in the evolution of Bianchi type-VI universe in the presence of stiff fluid ( $p = \rho$ ). Here, we have obtained exact solutions of Einstein field equations for three different cases depending upon the cosmological term  $\Lambda$  i. e

case (i):  $\Lambda = \frac{\alpha}{R^2} + \beta H^2$ ,

case (ii):  $\Lambda = \frac{\alpha}{R^2} + \beta H^2 + \gamma$  and

case (iii):  $\Lambda = \Lambda_0 + \Lambda_1 H + \Lambda_2 H^2$ .

- In the case (i), the universe starts expanding with zero volume and grows up at infinite past and future. By taking suitable values of constant, it is observed that  $\rho, \Lambda, \theta, \sigma$  and  $H$  are all infinite and at late time they become zero. It is well known that a positive  $\Lambda$  corresponds to the universal repulsive force, while a negative one gives an additional gravitational force. Therefore, the new anisotropic cosmological model Eq. (32) represents expanding, shearing and non-rotating universe for  $n = 1$ . But for  $n = 1$ , the model becomes isotropic.
- In the case (ii) also, we have obtained an anisotropic cosmological model for  $n > 1$ . It is observed that the volume is increasing with respect to time.
- Hence, the graphs of energy density in case (i) and case (ii) shows the evolution of universe for some suitable values of constants.
- In the last case where we assume  $\Lambda$  in quadratic form, from the graph, it is clear that the cosmological term  $\Lambda$  is decreasing function of time. Thus, the model represents shearing and non-rotating universe. From Eq. (66), the Collins

condition [56] is satisfied i. e  $\frac{\sigma}{\theta}$  is constant for this case.

- Therefore, our constructed cosmological models are of great importance in the sense that the nature of decaying vacuum energy density is supported by recent cosmological observations. In all the cases, we have shown that our cosmological model, which is homogeneous and anisotropic at the early stage of universe becomes isotropic for  $n = 1$ . The result of this paper agree with the observational features of the universe.

### REFERENCES RÉFÉRENCES REFERENCIAS

1. Weinberg S.: Rev. Mod. Phys. 61, 1 (1989).
2. Sahni V. and Starobinsky A. A.: Int. J. Mod. Phys. D9, 373 (2000).
3. Peebles P.J.E. and Ratra B.: Rev. Mod. Phys 75, 559 (2003).
4. Garnavich, P. M., et al.: Astrophysics J. 493, L53 (1998a).
5. Garnavich, P. M., et al.: Astrophysics J. 509, 74 (1998b).
6. Perlmutter S., et al.: Astrophysical J. 483, 565 (1997).
7. Perlmutter S., et al.: Astrophysical J. 517, 565 (1999).
8. Riess A. G., et al.: Astrophysical J. 116, 1009 (1998).
9. Schmidt B. P., et al.: Astrophys. J 507, 46 (1998).
10. Gasperini M. A. : Phys. Lett. B 194, 347 (1987).
11. Gasperini M. A. : Class. Quant. Grav 5, 521 (1988).
12. Berman M.S. : Int. J. Theor. Phys 29, 567 (1990).
13. Berman M.S. : Int. J. Theor. Phys 29, 1419 (1990).
14. Berman M.S. and Som M. M : Int. J. Theor. Phys 29, 1411 (1990).
15. Ozer M. and Taha M. O.: Nucl. Phys. B 287, 776 (1987).
16. Freese K, Adams F. C, Friemann J. A and Mottolla E.: Nucl. Phys. B 287, 797 (1987).
17. Ratra B and Peebles P. J. E.: Phys. Rev. D 37, 3406 (1988).
18. Chen W. and Wu Y. S.: Phys. Rev. D 41, 695 (1990).
19. Abdussattar and Vishwakarma R. G: Pramana J. Phys 47, 41 (1996).
20. Gariel J. and Le Denmat G.: Class. Quantum Grav 16, 149 (1999).
21. Pavon D.: Physical Review D 43, 375 (1991).
22. Holye F, Burbidge G, Narlikar J. V.: Monthly Notices of the Royal Astronomical Society 296, 173 (1997).
23. Olson T. S and Jordan T. F.: Physical Review D 35, 2528 (1987).
24. M. D and Silva G. S.: Physical Review D 50, 7233 (1994).
25. Silveira V. and Waga J.: Physical Review D. 56, 4625 (1997).
26. Silveira V. and Waga I.: Physical Review D. 50, 4890 (1994).

27. Torres L. F. B and Waga I.: Monthly Notices of the Royal Astronomical Society 279, 712 (1996).
28. Carvalho J. C, Lima J. A. S and Waga I.: Phys. Rev. D 46, 2404 (1992).
29. Waga I.: Astrophys. J. 414, 436 (1993).
30. Dwivedi U. K and Tiwari R. K.: International Journal of Physics and Mathematical Sciences 2, 2 (2012).
31. Barrow J. D.: Phys. Lett. B 180, 335 (1986).
32. Wesson P.S.: J. Math. Phys 19, 2283 (1978).
33. Wainwright J., Ince W. C. W., and Marshman B. J.: Gen. Rel. Grav 10, 259 (1979).
34. Collins C. B. and Hawking S. W.: Astrophys. J. 180, 317 (1973).
35. Ellis G. F. R and MacCallum M. A. H.: Commun. Math. Phys. 12, 20 (1969).
36. Dunn K. and Tupper B. O. J.: Astrophys J. 222, 405 (1978).
37. MacCallum M. A. H.: Astrophys J. 212, 946 (1977).
38. Roy S. R. and Bali R.: J. Math. Phys 25, 1456 (1984).
39. Bali R.: Int. J. Theor. Phys. 25, 7 (1986).
40. Roy S. R. and Banerjee S. K.: Gen. Rel. Grav. 24, 117 (1992).
41. Bali R. and Singh D. K.: Astrophys Space Science 300, 387 (2005).
42. Bali R., Tinker S. and Singh P.: Int J Theor Phys 49, 1431 (2010).
43. Singh C. P, Beesham A.: International Journal of Modern Physics A 25, 3825 (2010).
44. Baghel P. S and Singh J. P.: Research in Astron. Astrophys. 12, 1457 (2012).
45. Saha B., Rikhvitsky V. and Pradhan A.: Rom. Journ Phys. 60, 3 (2014).
46. Kotambkar S., Singh G. P. and Kelkar R.: Natural Science 7, 179 (2015).
47. Tiwari R. K and Singh R.: Int J Theor Phys 54, 1417 (2015).
48. Barrow J. D.: Mon. Not. R 211, 221 (1984).
49. Priyanka, Chandel S., Singh M. K. and Shri Ram.: Global Journal of Science Frontier Research Mathematics and Decision Sciences 12, 1 (2012).
50. Mishra B. and Biswal S. K.: The African Review of Physics 9, 0012 (2014).
51. Pradhan A.: Research in Astron. Astrophys 13, 139 (2013).
52. Saha B.: Int J. Theor Phys 52, 3646 (2013).
53. Verma M. K. and Shri Ram.: Applied Mathematics 2, 348 (2011).
54. Sadeghi J., Amani A. R. and Tahmasbi N.: Astrophysics Space Science 348, 559 (2013).
55. Singh J. P., Baghel P. S. and Singh A.: Proc. Natl. Acad. Sci., India, Sect. A Phys. Sci. 86(3), 355 (2016).
56. Collins C. B., Glass E. N., Wilkinson, D. A.: Gen. Relativ. Gravit. 12, 805 (1980).

This page is intentionally left blank





GLOBAL JOURNAL OF SCIENCE FRONTIER RESEARCH: A  
PHYSICS AND SPACE SCIENCE

Volume 16 Issue 6 Version 1.0 Year 2016

Type : Double Blind Peer Reviewed International Research Journal

Publisher: Global Journals Inc. (USA)

Online ISSN: 2249-4626 & Print ISSN: 0975-5896

# Effect of Radiation on Thermal Explosion Characteristics of Non-Newtonian Fluids

By Alalibo T Ngiangia & Sozo T. Harry

*University of port Harcourt*

**Abstract-** An analytical approach to the study of thermal explosion characteristics was examined and observation showed that an external heat source brought about by Semenov parameter and radiation delayed the initiation of thermal explosions while Frank-Kamenestkii parameter and heat due to chemical reaction enhanced the initiation of thermal explosions. The work also revealed that internal friction reduces ignition time and increases reaction rates.

**Keywords:** *newtonian fluids, non-newtonian fluid, thermal explosions, frank-kamenestkii parameter, semenov parameter.*

**GJSFR-A Classification:** FOR Code: 020304, 020303



*Strictly as per the compliance and regulations of :*



# Effect of Radiation on Thermal Explosion Characteristics of Non-Newtonian Fluids

Alalibo T Ngiangia <sup>α</sup> & Sozo T. Harry <sup>σ</sup>

**Abstract-** An analytical approach to the study of thermal explosion characteristics was examined and observation showed that an external heat source brought about by Semenov parameter and radiation delayed the initiation of thermal explosions while Frank-Kamenestkii parameter and heat due to chemical reaction enhanced the initiation of thermal explosions. The work also revealed that internal friction reduces ignition time and increases reaction rates.

**Keywords:** newtonian fluids, non-newtonian fluid, thermal explosions, frank-kamenestkii parameter, semenov parameter.

A = reactant

B = product

T = temperature of the reacting fluid

t = reaction time

k = thermal conductivity

$x$  = space coordinate

$\psi$  = consistency index

u = fluid velocity

$\alpha$  = flow behaviour index (power law exponent)

$\chi$  = heat transfer coefficient

S = surface area of fluids

V = volume of fluids

$T_0$  = characteristic temperature

Q = heat released or absorbed

C = reactant concentration

R = universal fluid constant

$k_0$  = constant

m = numerical exponent

E = activation energy

$\rho$  = fluid density

P = fluid pressure

$\delta$  = Frank-Kamenestkii parameter

$\psi$  = Semenov parameter

$\theta$  = dimensionless temperature

$y$  = dimensionless space coordinate

$\rho'$  = dimensionless fluid density

$\beta$  = dimensionless thermal conductivity

$\mu$  = dimensionless heat absorbed or released

$\lambda$  = dimensionless activation energy

$\tau$  = dimensionless time

q = quantity of heat in the reaction

$T_\infty$  = reservoir temperature

$\Lambda$  = Planck's function

$\alpha_{K^*}$  = absorption coefficient

$\kappa^*$  = frequency of radiation

$q_x$  = radiative term

## I. INTRODUCTION

Fluid dynamics is one of the most important of all areas of physics. Life as we know it would not exist without fluids. Fluids occur, and often dominate physical phenomena on all macroscopic length scales of the universe, from the mega per seconds of galactic down to the nanoscales of biological cell activity [1]. In reality communication would not have been possible without fluid (air) and the study as well as the practice of engineering cannot be complete without fluids. However, it is of common knowledge that most of the common and popular fluids in our day to day interactions are classified as Newtonian fluids and therefore most studies of fluid, concentrated on Newtonian fluids because, they obey the simple relationship between shear stress and shear strain. However, many common fluids are also Newtonian. Non-Newtonian fluids are fluids that do not obey the Newton's law of viscosity. For such fluids the shear stress is not proportional to the velocity gradient. These classes of fluids possesses flow power index of two and above. The viscosity of such fluids is also of higher magnitude than the Newtonian fluids. In the analysis of non-Newtonian fluids, Hughes and Briton [2] opined that, the properties of non-Newtonian fluids do not lend themselves to the elegant and precise analysis that has been developed for Newtonian fluids but the flow of non-Newtonian fluids does possess some interesting, useful and even exciting characteristics. In the construction industries, the use of paints, drilling mud and coal tar cannot be overemphasized owing to their chemical composition and physical properties. Scholars have made invaluable contribution to the study of non-Newtonian fluids and thermal explosion characteristics. When the heat loss due to Newtonian cooling can no longer keep pace with the heat release due to exothermic reaction, an additional heat source is considered [3-4]. Dik [5] also proposed a constant additional heat source in order to answer the question of

Author  $\alpha$ : Department of Physics, University of Port Harcourt, P M B 5323, Choba, Port Harcourt, Nigeria. e-mail: kellydap08@gmail.com

Author  $\sigma$ : Department of Physics, Ignatius Ajuru University of Education, Rumuolumeni Port Harcourt.

degeneracy and also to estimate the ignition limits in such a system. Ajadi and Gol'dshtein [6], in their study, presented chemical and mechanical heat sources to thermal explosion characteristics and reported results which in part were a clear departure from existing results. Truscott et al [7] stated that, by assuming a slow rate of consumption of fuel and oxygen, the behaviour of a full system can be approximated and the safe and dangerous regions of parameter space can be identified. Adegbe [8] and Ngiangia et al [9] in their separate studies also reported that increase in Semenov parameter, decreases the temperature and this could lead to delay in the initiation of thermal explosions. Ngiangia [10], considered thermal explosion characteristics on Newtonian and non-Newtonian fluids and opined that in both cases, an additional heat source, delayed early initiation of thermal explosions but in varying degrees. Our aim in this study is to consider radiation as an additional heat source and investigate its contribution to the initiation of thermal explosions.

## II. FORMALISMS

The mathematical statement of the study suggests that the velocity gradient is a function of temperature and the power law exponent varies. Using these facts and assuming that the reaction taking place in the region under study is one-step and irreversible



The simplified energy equation takes the form

$$\rho C_p \frac{\partial T}{\partial t} = k \frac{\partial^2 T}{\partial x^2} + \varphi \left( \frac{\partial u}{\partial x} \right)^\alpha - \chi \frac{S}{V} (T - T_0) + q - \frac{\partial q_x}{\partial x} \quad (2)$$

$$\frac{\rho C_p}{k} \frac{\partial T}{\partial t} = \frac{\partial^2 T}{\partial x^2} + \left( \frac{3}{2} x \right) \left( \frac{3 \rho R}{2 \delta} \right) - \frac{\chi S}{V k} (T - T_0) + \frac{1}{k} Q^{k_0 \left( \frac{T}{T_0} \right)^m} C \exp \left( - \frac{E}{RT} \right) - \frac{4 \delta^2 (T - T_\infty)}{k} \quad (9)$$

## III. DIMENSIONLESS VARIABLES

The following dimensionless quantities have been used

$$\rho' = \frac{\rho u^2 x}{p}, R' = \frac{R p x^2}{T_0}, \psi = \frac{\chi S R T_0^2}{V Q k C E} \exp \left( \frac{-E}{RT_0} \right), \xi = \frac{3 \rho R T}{P}, \mathcal{G} = \frac{\rho V C_p}{k M C_v}$$

$$\tau = \frac{t}{t_0}, \theta = \frac{T}{T_0}, \delta = \frac{\varphi}{k}, \beta = \frac{R T_0}{E}, \mu = \frac{Q C}{E \rho}, y = \frac{3 x}{2 u t}, r = k_0 \exp \left( - \frac{1}{\beta} \right)$$

and equation (9) can be written as

$$\mathcal{G} \frac{\partial \theta}{\partial \tau} = \frac{\partial^2 \theta}{\partial y^2} + \frac{\xi}{\delta} y \frac{\partial \theta}{\partial y} - \psi \theta + r \theta^m \log_e \mu - N \theta \quad (10)$$

with the boundary conditions  $\theta(0) = 0, \theta(1) = 1$  (11)

## IV. SOLUTION

If  $m = 1$ , ignition time is of utmost importance in thermal ignition. In the absence of reactant consumption and other simplification, equation (11) takes the form

and the heat released by the chemical reaction is expressed by the Arrhenius law and obey the characteristics of non-Newtonian fluids

$$q = Q^{k_0 \left( \frac{T}{T_0} \right)^m} C \exp \left( - \frac{E}{RT} \right) \quad (3)$$

$$\frac{\partial^2 q_x}{\partial x^2} - 3 \sigma^2 q_x - 16 \sigma T_\infty^3 \frac{\partial T}{\partial x} = 0 \quad (4)$$

For optically thin medium with relatively low density in the spirit of [10], equation (4) reduces to

$$\frac{\partial q_x}{\partial x} = 4 \delta^2 (T - T_\infty) \quad (5)$$

$$\text{where } \delta^2 = \int_0^\infty (\alpha_{k^*} \frac{\partial \wedge}{\partial T}) dk^*$$

with the boundary conditions  $T(0) = 0, T(1) = 1$  (6)

It has been established by Hughes and Brighton [2] that

$$\varphi \left( - \frac{\partial u}{\partial x} \right)^\alpha = - \frac{x}{2} \left( \frac{\partial p}{\partial x} \right) \quad (7)$$

The equation of state for an ideal fluid is given by

$$p = \rho R T \quad (8)$$

For non-Newtonian fluid flow and application of expansion using linear approximation of the second term on the right hand side we get

In the explosion region, the heat loss can be neglected ( $\psi = N = 0$ ) and taking high activation energy, ignition time approaches the adiabatic ignition time hence

$$\tau = \int_0^\infty \frac{d\theta}{-\psi \theta + (r \log_e \mu) \theta - N \theta} \quad (12)$$

$$\tau = \int_0^{\infty} \frac{d\theta}{(r \log_e \mu) \theta} = (\log_e \mu) \log_e \theta \exp\left(\frac{E}{RT}\right) \quad (13)$$

which is an extension of known result for ignition time [12]

The presence of internal friction as a result of additional heat source, results in reduction of ignition time and also increases the rate of reaction.

To solve (10), we take steady state and using the Frobenius method for special functions, we assume a solution of the form

$$\theta = \sum_{n=0}^{\infty} a_n y^{n+c} \quad (14)$$

$$\theta = C_0 \left( \frac{y - \left( \frac{\xi}{\delta} - \psi + r \log_e \mu - N \right) y^2}{3!} \right) + C_1 \left( \frac{y^2 - \left( \frac{2\xi}{\delta} - \psi + r \log_e \mu - N \right) y^4}{4!} \right) \quad (17)$$

$$\text{where } C_0 = \left( \frac{3!}{1 - \left( \frac{\xi}{\delta} - \psi + r \log_e \mu - N \right)} \right), C_1 = \left( \frac{4!}{1 - \left( \frac{2\xi}{\delta} - \psi + r \log_e \mu - N \right)} \right)$$

## V. RESULTS AND DISCUSSION

In order to get physical insight and numerical validation of the problem, an approximate value  $r = 12.34$  and  $\xi = 2.5$  is chosen. The values of other parameters made use of are

$$\mu = 2.5, 3.5, 4.5, 5.5, 6.5$$

$$\delta = 0.5, 1.0, 1.5, 2.0, 2.5$$

$$N = 1.6, 2.6, 3.6, 4.6, 5.6$$

$$\psi = 0.7, 1.2, 1.7, 2.2, 2.7$$

Frank-Kamenestkii considered a situation whereby heat is transported with relatively low thermal conductivity within the reactants, at such, increase in its parameter as depicted in Figure 1, showed a corresponding increase in the temperature of the reacting fluid which in turn brings about early initiation of thermal explosions. This observation is in agreement with the studies of [6], [9] and [10]. Increase in Semenov parameter as depicted in Figure 2, shows a corresponding decrease in the minimum temperature of the fluid owing to intermolecular interactions of a viscous reactive substance. This observation is consistent with the work of [6]. The presence of additional heat source provoked by chemical reaction led to the presence of internal friction. This additional heat contribution leads to

We put (14) into (10) and simplify, we get roots of the indicial equations as

$$C = 0 \text{ or } 1 \quad (15)$$

which lead to the recurrence relation

$$a_{n+2} = \frac{-\left(\frac{\xi}{\delta}(n+c) - \psi + r \log_e \mu - N\right) a_n}{(n+c+2)(n+c+1)} \quad n = 0, 1, 2, \dots \quad (16)$$

The complete solution after the imposition of (11) is

increase in minimum temperature and an early occurrence of thermal explosion as depicted in Figure 3. The result is in agreement with [6]. Radiation, which is energy in motion decreases the minimum temperature of the reacting fluid as its parameter is increased as shown in Figure 4. Its presence, boost the Semenov parameter thereby further delayed the initiation of thermal explosions.

## VI. CONCLUSION

The influence of radiation as an additional heat source in combination with chemical reaction and Semenov parameter were analyzed theoretically and its interest in the industries, particularly where dynamics of viscous reactive materials are considered, is a suitable area of application of this study.

## VII. ACKNOWLEDGEMENTS

The author was supported by the Theoretical Physics Research Group of the University of Port Harcourt.

## REFERENCES RÉFÉRENCES REFERENCIAS

1. J. M McDonough, Lectures in elementary fluid dynamics. Lexington, KY 40506-0503 (2009).

2. W. F Hughes and J. A Brighton. Fluid Dynamics (Third edition). Schaum's Outlines, McGraw-Hill, New York. (1999).
3. A. D Margolin. Zh. Fiz. Khim. 37 (1963) 887.
4. A.G Merzhanov and F. I Dubovitskii. Russ. Chem. Rev. 35 (1966) 278.
5. I. G Dik. Fiz. Goreniya I Vzryva. 16. (1980) 596.
6. S. O Ajadi and V. Gol'dshtein. Jour. Maths. Scien. 1 (2010) 36.
7. J. E Truscott, J. Brindley, A McIntosh and J Griffiths. IMA J of Appl. Maths. 57 (1996) 257.
8. K. S Adegbe. J of NAMP 13 (2008) 69.
9. A. T. Ngiangia, O. Amadi and S. T Harry. Int. Jour. of Dyn. Fluids. 9(1) (2013) 29.
10. A.T Ngiangia. World Scientific News. 40 (2016) 223
11. A. C Cogley, A. W Vincenti and E. S Giles. ATAA Journal. 6. (1968) 551.
12. P. Simon and L Kolman. J of Thermal analysis and Calorimetry . 64 (2001) 813.

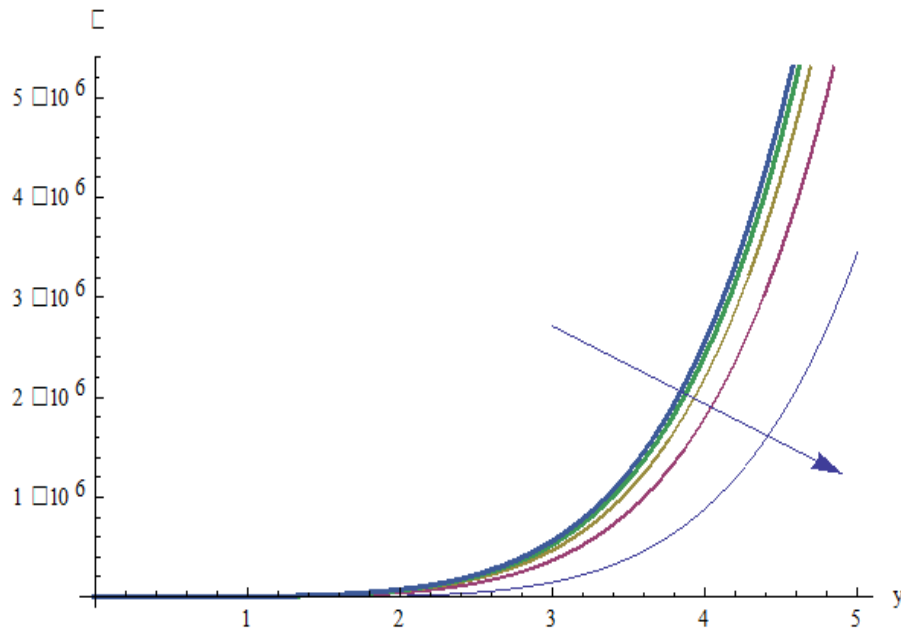

Figure 1: Temperature profile  $\theta$  against boundary layer  $y$  for varying Frank-Kamenestkii parameter  $\delta$

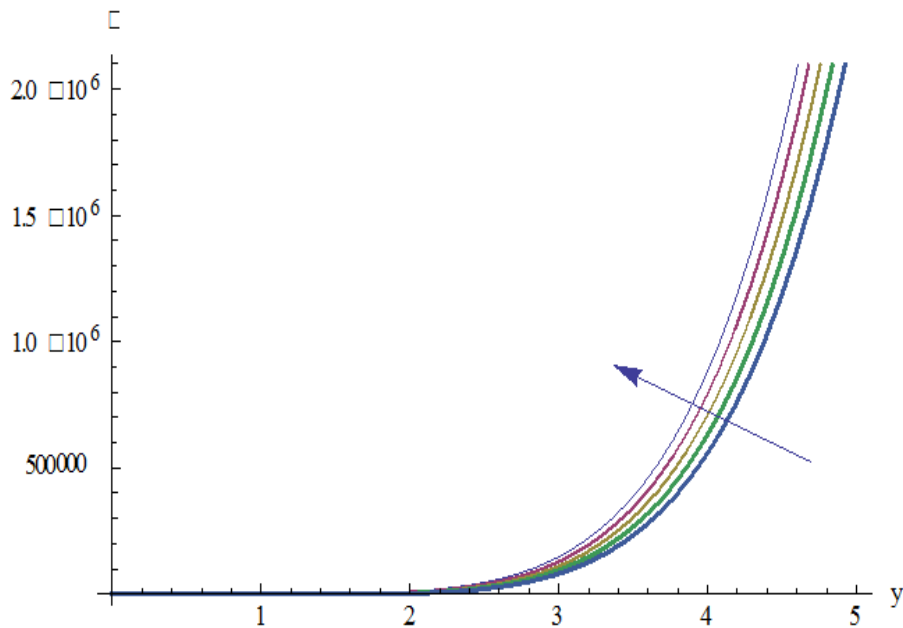

Figure 2: Temperature profile  $\theta$  against boundary layer  $y$  for varying Semenov parameter  $\psi$

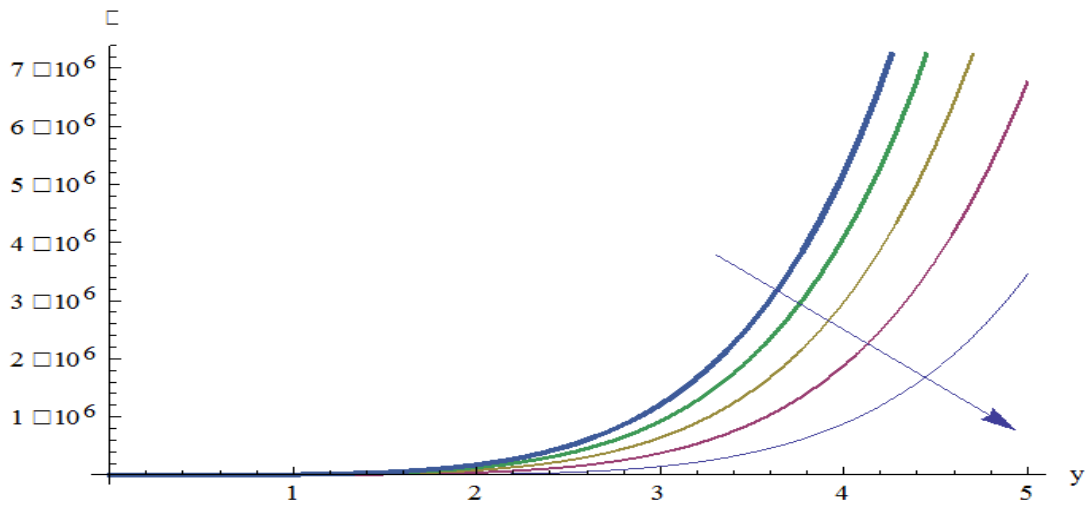

Figure 3: Temperature profile  $\theta$  against boundary layer  $y$  for varying Heat source  $\mu$

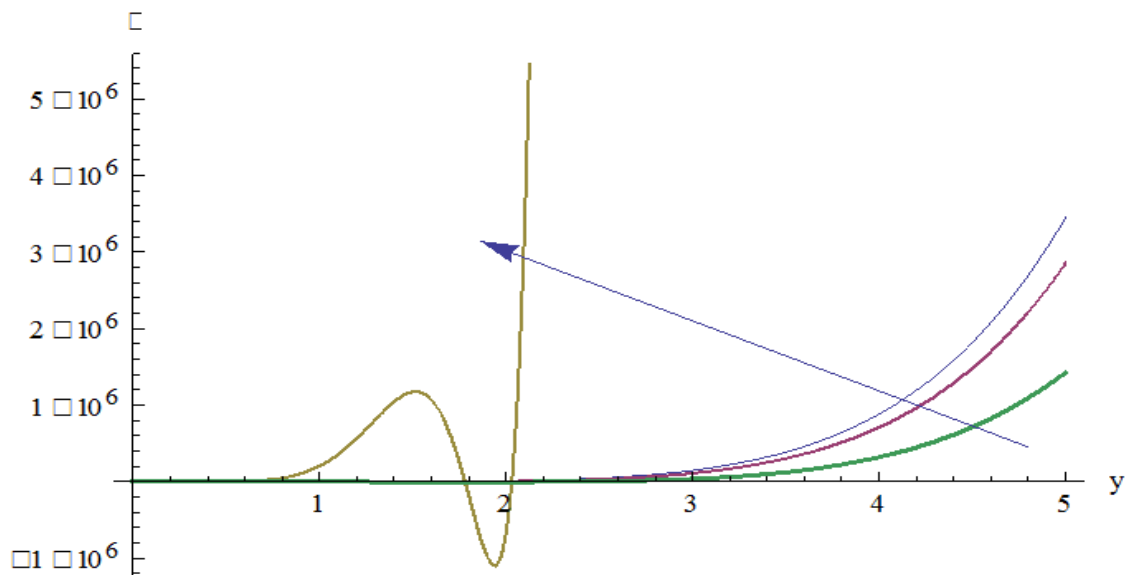

Figure 4: Temperature profile  $\theta$  against boundary layer  $y$  for varying Radiation parameter  $N$



This page is intentionally left blank



GLOBAL JOURNAL OF SCIENCE FRONTIER RESEARCH: A  
PHYSICS AND SPACE SCIENCE  
Volume 16 Issue 6 Version 1.0 Year 2016  
Type : Double Blind Peer Reviewed International Research Journal  
Publisher: Global Journals Inc. (USA)  
Online ISSN: 2249-4626 & Print ISSN: 0975-5896

# Cutting-off Einstein's Special Relativity Theory by Occam's Sickle (How the Mountain (Large Hadron Collider) has Brought Forth a Mouse) Mamaev A. V., Candidate of Engineering Sciences, Bureau Chief JSC "Lianozovo Electromechanical Plant R&P Corp.", Russia

By Anatoly Mamaev

**Abstract-** Einstein's special relativity theory published in 1905 was really based not on two principles, but on three principles. The first principle was the principle of relativity (Einstein's first postulate). The so called second Einstein's postulate can be separated in two independent principles: 1. Light emitted by a source being at rest in a "stationary" inertial reference frame moves in this frame at the speed  $c_0 = 299792458$  m/s; 2. Light speed in a "moving" inertial reference frame is also equal to the same value  $c_0$ . My purpose consists in decreasing number of Einstein's postulates by refusal from the law of independence of light speed upon light source speed that is actually the third Einstein's principle.

**Keywords:** *special relativity theory, light clock, time measurement unit, dependence of light speed upon light source speed, dependence of particle electrical charge upon particle speed, superlight speeds of particles, experimental confirmation of superlight speeds and existence of charge upon speed dependence.*

**GJSFR-A Classification:** FOR Code: 029999



Strictly as per the compliance and regulations of :





# Cutting-off Einstein's Special Relativity Theory by Occam's Sickle (How the Mountain (Large Hadron Collider) has Brought Forth a Mouse)

Mamaev A. V., Candidate of Engineering Sciences, Bureau Chief JSC "Lianozovo Electromechanical Plant R&P Corp.", Russia

Anatoly Mamaev

Year 2016

55

Version I

Issue VI

Volume XVI

Research (A)

Frontier

Journal of

Science

Global

Journal of

Science

Frontier

Research

(A)

Volume

XVI

Issue

VI

Year

2016

**Abstract-** Einstein's special relativity theory published in 1905 was really based not on two principles, but on three principles. The first principle was the principle of relativity (Einstein's first postulate). The so called second Einstein's postulate can be separated in two independent principles: 1. Light emitted by a source being at rest in a "stationary" inertial reference frame moves in this frame at the speed  $c_0 = 299792458$  m/s; 2. Light speed in a "moving" inertial reference frame is also equal to the same value  $c_0$ . My purpose consists in decreasing number of Einstein's postulates by refusal from the law of independence of light speed upon light source speed that is actually the third Einstein's principle. Equality of time measurement units in two light clocks of identical design moving each with respect another one uniformly and rectilinearly is a consequence from the relativity principle and this equality discards the moving clock retardation with respect to a stationary clock. Logunov's method is used for deriving new transformation instead of Lorentzian one. My theory based on two principles (relativity principle and the principle of light speed in a stationary inertial reference frame from an immovable source) does not forbid superlight speeds. Besides the known Lorentzian speed of particles motion, the Galilean speed varying from zero to infinity is used. Instead of independence of particle electrical charge value resulting from Lorentzian transformation, a law of dependence of particle electrical charge value upon particle speed is derived. The experiment by Neddermeyer and Anderson in 1938 is interpreted as a confirmation of superlight speeds and dependence of electric charge upon particles speed existence in nature. Formulas of new particle dynamics are derived from new theory transformation.

**Keywords:** special relativity theory, light clock, time measurement unit, dependence of light speed upon light source speed, dependence of particle electrical charge upon particle speed, superlight speeds of particles, experimental confirmation of superlight speeds and existence of charge upon speed dependence.

Author: e-mail: scientist02@mail.ru

## I. INTRODUCTION

From the history of physics we know, that Newton's theory was based upon three main laws, Einstein in 1905 considered that his special relativity theory (SRT) [1] was based upon two principles-postulates:

1. "The laws, by which the states of physical systems undergo change, are not affected, whether these changes of state be referred to the one or the other of two systems of co-ordinates in uniform translatory motion".
2. "Any ray of light moves in the "stationary" system of co-ordinates with the determined velocity  $c_0$ , whether the ray be emitted by a stationary or by a moving body".

But now, when it is high time to decrease the quantity of principles adopted as the foundation of the space-time theory using the Occam's sickle, it is expedient to determine more precisely what really is the quantity of principles in Einstein's special relativity theory.

It seems to me that Einstein's second postulate can be separated in two statements:

- 2.1. Any ray of light emitted by a source, immovable in the "stationary" inertial reference frame (IRF) moves in this frame with a determined velocity  $c_0 = 299792458$  m/s.
- 2.2. Any ray of light moves in the IRF "moving" uniformly and rectilinearly with regard to the "stationary" IRF, in which the light source is immovable, with the same velocity  $c_0$ . This statement can be named as a law of light speed independence on light source speed.

The first of these two statements can not be wrong, because it is a result of real measurements. Therefore my purpose may consist only in refusal from the second statement – from the law of light speed independence on the light source speed.

My purpose consists in creating the theory better than Einstein's SRT. In order to create a new theory, that can be better than old Einstein's SRT, I decided to use Occam's advice known as the Occam's sickle: "Things that can be explained by means of lesser arguments should not be explained by means of more arguments".

Meditating about Einstein's SRT I put a question: "How can we reduce the quantity of principles used as a foundation for the SRT?" The answer was such: our purpose could be obtained, if we could find some consequence from one of Einstein's principles that could replace the other postulate converting it into a superfluous one. After some hesitations I decided to use the principle of relativity as the first reliable principle capable to be included into the basis of my new space-time theory. The second principle, which I included in the foundation of my space-time theory, was the statement 2.1 (see above). Because I discovered that Einstein's SRT is a self-contradictory theory. Because the above statement 2.2 contradicts such a consequence of the relativity principle as the equality of time measurement units in two light clocks of identical design moving uniformly and rectilinearly each with respect the other.

## II. SELF-CONTRADICTIONALITY OF EINSTEIN'S SRT AND ITS ELEGANT ELIMINATION IN THE NEW SPACE-TIME THEORY

Now it is well known that a light clock (consisting of two parallel mirrors, a photoelectric sensor on one of mirrors, a pulse counter connected to the output of the photoelectric sensor and a light pulse circulating between mirrors) is a physical system, which must comply with the relativity principle

Because the relativity principle with respect to such a physical system as the light clock must read:

*The laws, by which the indications of a light clock undergo change, are not affected, whether these changes of indications be referred to the one or the other of two systems of co-ordinates in uniform translatory motion.*

That means that time dilation effect existing in the SRT according to the relativity principle should be absent. Indeed, if we consider that distance between mirrors of a stationary light clock is equal to  $L_0$ , then the time measurement unit for a stationary light clock is equal to the value

$$T_0 = \frac{2L_0}{c_0}. \quad (2.1)$$

And the time measurement unit for the same light clock, moving at the speed  $V$  in a direction perpendicular to planes of light clock mirrors, in case of an assumption that light speed in a moving light clock also is equal to  $c_0$  will be equal to the value

$$T = \frac{L}{c_0 - V} + \frac{L}{c_0 + V}, \quad (2.2)$$

$$\text{where } L = \frac{L_0}{\gamma} = L_0 \sqrt{1 - V^2/c_0^2} \quad (2.3)$$

is the distance (according to the SRT) between light clock mirrors, moving at the speed  $V$ .

Having substituted the equality (2.3) into the equation (2.2) and having performed all mathematical operations in it, we obtain instead of the formula (2.2) the equation

$$T = \frac{L}{c_0 - V} + \frac{L}{c_0 + V} = \gamma T_0, \quad (2.4)$$

where  $\gamma = \frac{1}{\sqrt{1 - V^2/c_0^2}}$  is a relativistic factor;  $V$  is the Lorentzian speed of motion that can not be greater than the light speed in vacuum  $c_0$ .

Thus, the assumption that the light speed in a moving inertial reference frame (IRF) is also equal to the same value  $c_0$ , leading to the existence of time dilation effect in the SRT, leads to a contradiction with the relativity principle (indications of a light clock depend on what IRF these indications are referred to). Therefore it is expedient to explore what value of the light speed in a moving IRF will not lead to a contradiction with the relativity principle, that is to examine what value of light speed in a moving IRF will result in equality of time measurement units for stationary and moving light clocks of the precisely similar design.

In order to get rid of the said above contradiction in the SRT let us replace in the right part of the equation (2.2) instead of the Lorentz's speed  $V$  that cannot exceed the value  $c_0$  the Galilean speed  $u$  and instead of light speed  $c_0$  in a stationary inertial reference frame (IRF) the speed of light in the moving IRF derived in [2, p. 140]

$$w = \gamma c_0 = c_0^2 + u^2, \quad (2.5)$$

where  $\gamma = \frac{1}{\sqrt{1 - V^2/c_0^2}} = \sqrt{1 + u^2/c_0^2}$  is a relativistic factor, we obtain

$$T = \frac{L}{w - u} + \frac{L}{w + u}. \quad (2.6)$$

Then, substituting into the equation (2.6) the expression (2.3), we obtain

$$T = \frac{L_0}{\gamma} \left( \frac{1}{w - u} + \frac{1}{w + u} \right) = \frac{L_0}{\gamma} \frac{2w}{w^2 - u^2} \quad (2.7)$$

and substituting into the equation (2.7) the equation (2.5) we obtain

$$T = \frac{L_0}{\gamma} \frac{2w}{w^2 - u^2} = \frac{L_0}{\gamma} \frac{2\gamma c_0}{c_0^2 + u^2 - u^2} = \frac{2L_0}{c_0} = T_0. \quad (2.8)$$

Thus, having refused from the statement 2.2, we after introduction of equation (2.5) obtained that relativity principle becomes valid for the light clock too and the contradiction between time measurement units of stationary and moving light clocks (existing in Einstein's SRT) disappears.

### III. DERIVATION OF SPACE-TIME COORDINATES TRANSFORMATION OF THE NEW THEORY

Derivation of space-time coordinates transformation from a stationary primed IRF to a moving unprimed IRF (or vice versa) we shall perform using Logunov's method [3, p. 33].

Let us consider two IRF moving each with respect the other uniformly and rectilinearly: the IRF **A** with unprimed space-time coordinates  $x, y, z, t$  and the IRF **B** with primed coordinates  $x', y', z', t'$ . Let all the clocks being at rest in the IRF **A** be synchronized each with other using Einstein's method by means of light sources being at rest in the same IRF **A** and all clocks being at rest in the IRF **B** be synchronized each with other using Einstein's method by means of light sources being at rest in the same IRF **B**.

Let the IRF **B** with primed coordinates  $(x', y', z', t')$  be a stationary IRF and the IRF **A** with unprimed coordinates  $(x, y, z, t)$  be a moving IRF at the speed  $u$  in negative direction of the axis  $X'$  of the stationary IRF **B**.

Then in the stationary IRF **B** the light propagates at the speed  $c_0$  and in the moving IRF **A** this light propagates at the speed that is determined by an expression  $c_u = c_0 \sqrt{1 + u^2 / c_0^2}$ . As a consequence an expression for the interval in Galilean coordinates of a moving IRF **A** has the form

$$ds^2 = c_u^2 dt^2 - dx^2 - dy^2 - dz^2. \quad (3.1)$$

Let us perform over expression (3.1) the Galilean transformation

$$x'' = x - ut, \quad t'' = t, \quad y'' = y, \quad z'' = z. \quad (3.2)$$

For that purpose let us write a transformation inverse to transformation (3.2)

$$x = x'' + ut'', \quad t = t'', \quad y = y'', \quad z = z'', \quad (3.3)$$

where  $x, y, z, t$  are Galilean coordinates of any event in the IRF **A**.

Having taken differentials from the both parts of equalities (3.3) and having substituted them into the expression (3.1), we have

$$ds^2 = c_0^2 (dt'')^2 - 2udx''dt'' - (dx'')^2 - (dy'')^2 - (dz'')^2. \quad (3.4)$$

In order to dispose in the right part of the expression (3.4) from a cross term  $dx''dt''$ , let us separate a perfect square in it. In the result of this operation the interval (3.4) acquires the form

$$ds^2 = c_0^2 \left[ dt'' - \frac{udx''}{c_0^2} \right]^2 - \frac{(dx'')^2}{1 - \frac{u^2}{c_u^2}} - (dy'')^2 - (dz'')^2. \quad (3.5)$$

Now let us introduce a new time

$$t' = t'' - \frac{ux''}{c_0^2} \quad (3.6)$$

and new coordinates

$$x' = \frac{x''}{\sqrt{1 - \frac{u^2}{c_u^2}}}, \quad y' = y'', \quad z' = z''. \quad (3.7)$$

Then the expression (3.5) for the interval in these variables will have the form

$$ds^2 = c_0^2 (dt')^2 - (dx')^2 - (dy')^2 - (dz')^2. \quad (3.8)$$

But the expression (3.8) is an expression for the interval in Galilean coordinates of the stationary IRF **B**.

Thus, having applied consequently transformation (3.2) and transformations (3.6) – (3.7) we passed from the interval (3.1) in the moving IRF **A** to the interval (3.8) in the stationary IRF **B**. That means that after substitution of the expression (3.2) into expressions (3.6) and (3.7) we shall obtain transformation of coordinates and time from the moving IRF **A** to the stationary IRF **B**

$$c_0 t' = \gamma(c_u t - \beta x), \quad x' = \gamma(x - \beta c_u t), \quad y' = y, \quad z' = z, \quad (3.9)$$

where  $\beta = \frac{u}{c_u}$ ;  $\gamma = \frac{1}{\sqrt{1 - \beta^2}}$ ;  $c_u = c_0 \sqrt{1 + \frac{u^2}{c_0^2}}$ .

Having resolved transformation (3.9) with respect to unprimed coordinates, we shall have the transformation

$$c_u t = \gamma(c_0 t' + \beta x'), \quad x = \gamma(x' + \beta c_0 t'), \quad y = y', \quad z = z'. \quad (3.10)$$

This transformation provides transfer of space-time coordinates of any event from a stationary primed IRF to a moving unprimed IRF.

#### IV. DISSIMILARITIES OF THE NEW THEORY FROM EINSTEIN'S SRT

*The first* essential dissimilarity of the new relativistic space-time theory (NRSTT) from Einstein's SRT is the absence of the law of light speed independence on the light source speed.

*The second* essential dissimilarity of the NRSTT from Einstein's SRT is the dependence of light speed propagation upon light source speed having the form

$c_u = \sqrt{c_0^2 + u^2}$ . In the result of investigation of light propagation with such dependence along astronomical distances by computer simulation I discovered, first of all, that such phenomena as novas and supernovas, as well as pulsars can be explained as different effects arising from movement of light from different semi-ellipses of elliptical movement of binary stars. When the binary stars move with increasing speed from apastrons to periastrons, the light quanta emitted by them during the whole semi-period at large distance from a binary star to an observer can arrive to an observer practically simultaneously (during some months) while the semi-period itself can last during some hundreds of years or even during some thousands of years [4, p. 10]. These light quanta arriving to the remote observer practically simultaneously seem to this remote observer as a tremendous burst, known as a supernova. So, supernovas are also stars with repeated bursts of brightness. The period of such bursts is equal to a period of binary stars movement along elliptical trajectory. Such a period can be equal to some thousands of years. If the bursts of binary stars brightness last only some months, then the energy of any supernova burst is simply the sum of light quanta energy emitted by stars of a binary system during a very long half-period (that can be equal to thousands of years) of their movement along elliptical orbit that arrive to a remote observer (because of light speed dependence on the speed of light source) during only some months. When the stars of a binary system move with decreasing speed from periastrons to apastrons, the light quanta emitted by them during the whole semi-period are seen by a remote observer as a pulsar [4, p.10].

The subsequent analysis of dependence

$c_u = \sqrt{c_0^2 + u^2}$  has shown, that almost all effects connected with the so called "Universe expansion" can be explained by this dependence of light propagation speed upon the speed of light source motion having the form  $c_u = \sqrt{c_0^2 + u^2}$ . Among these effects we can see: Olbers's paradox, red shift of light spectrums from far stars, microwave background radiation, object SS-433, bursts of X-rays and gamma-rays, accelerated expansion of the Universe, etc. At that the expansion itself (as a natural phenomenon) disappears.

New effects from astronomical phenomena that can not now be explained by modern orthodox physics are luminous arcs similar to the one shown in the image of Fig. 1 below from the Hubble telescope [5].

From point of view of the NRSTT this "bright sharp arc" can be explained as a part of elliptic trajectory of one star from an unknown binary system, that occurred to be at such a distance from the Solar system that the ellipse is resolved and moreover the light from a part of ellipse arrived to the Hubble telescope simultaneously (in the result of light speed dependence on the light source speed) in such a way that it has drawn up this "bright sharp arc". Such explanation of both bright arcs and supernovas is prohibited by Einstein's second postulate. According to it light speed can not depend upon speed of light sources.

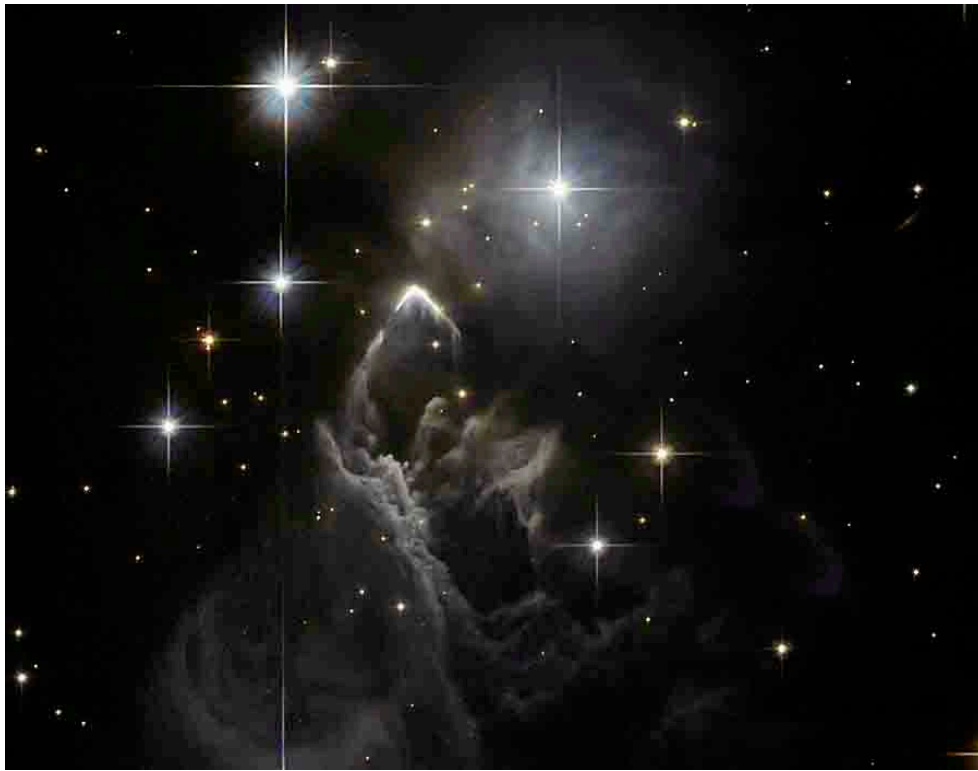

Fig. 1: A "bright sharp arc" from the Hubble telescope. [5]

Explanation to the photo in Fig. 1 from [5] is such:

"What's lighting up nebula IRAS 05437+2502? No one is sure. Particularly enigmatic is the bright upside-down V that defines the upper edge of this floating mountain of interstellar dust, visible near the image center. In general, this ghost-like nebula involves a small star forming region filled with dark dust that was first noted in images taken by the IRAS satellite in infrared light in 1983. Shown above is a spectacular, recently released image from the Hubble Space Telescope that, although showing many new details, has not uncovered a clear cause of the bright sharp arc. One hypothesis holds that the glowing arc was created by a massive star that somehow attained a high velocity and has now left the nebula. Small, faint IRAS 05437+2502 spans only 1/18th of a full moon toward the constellation of the Bull (Taurus)".

**The third** essential dissimilarity is the absence of superlight speeds prohibition.

Indeed, the Lorentz transformations from the SRT have the form

$$c_0 \cdot t' = \frac{c_0 \cdot t - \beta \cdot x}{\sqrt{1 - \beta^2}}, \quad x' = \frac{x - \beta \cdot c_0 \cdot t}{\sqrt{1 - \beta^2}}, \quad y' = y, \quad z' = z, \quad (4.1)$$

$$c_0 \cdot t = \frac{c_0 \cdot t' + \beta \cdot x'}{\sqrt{1 - \beta^2}}, \quad x = \frac{x' + \beta \cdot c_0 \cdot t'}{\sqrt{1 - \beta^2}}, \quad y = y', \quad z = z', \quad (4.2)$$

where  $\beta = V/c_0$ ,  $V$  is the Lorentz speed of motion of one IRF with respect to another IRF,  $c_0 =$

299 792 458 m/s is the speed of light in vacuum of the stationary IRF.

From Lorentz's transformations (4.1), (4.2) it can be seen that Lorentz's speed of IRF motion  $V$  under the SRT can not be greater than the speed of light in vacuum  $c_0$ . Indeed, if the speed of IRF motion exceeds the speed of light in vacuum  $c_0$ , square roots in denominators of transformations (4.1), (4.2) become imaginary numbers not existing on the assemblage of real numbers.

Such a prohibition on existence of superlight speeds disappears from the new relativistic space-time theory. Indeed, transformations (3.9), (3.10) of the new theory have the form respectively

$$x = \frac{x' + \beta c_u t'}{\sqrt{1 - \beta^2}}, \quad y = y', \quad z = z', \quad c_u t = \frac{c_0 t' + \beta x'}{\sqrt{1 - \beta^2}}, \quad (4.3)$$

$$x' = \frac{x - \beta c_u t}{\sqrt{1 - \beta^2}}, \quad y' = y, \quad z' = z, \quad c_0 t' = \frac{c_u t - \beta x}{\sqrt{1 - \beta^2}}, \quad (4.4)$$

where  $\beta = \frac{u}{c_u}$ ,  $c_u = \sqrt{c_0^2 + u^2}$  is the speed of light in vacuum of a moving IRF,  $c_0$  is the speed of light in vacuum of a stationary IRF.

From transformations (4.3), (4.4) of the new theory it is well seen, that no matter how great the IRF speed  $u$  can be, the speed of light in vacuum of the moving IRF  $c_u = \sqrt{c_0^2 + u^2}$  will be greater and no

imaginary numbers do appear in the new theory. Consequently, the prohibition on superlight speed of motion, existing in Einstein's SRT, in the new theory is absent.

**The fourth** dissimilarity of the new theory from Einstein's SRT consists in absence of moving light clock retardation from the stationary light clock (in absence of time dilation in the moving IRF).

In order to make oneself sure in absence of moving clock retardation, let us place the equality  $x' = 0$  into the equations (4.3), considering that in the primed IRF the light clock is at rest in the point  $x' = 0$ .

Then as a result of such substitution we shall obtain for coordinates of the clock in the unprimed IRF at any time moment the values:

$$t = t', \quad x = u \cdot t, \quad y = y', \quad z = z'. \quad (4.5)$$

From the first equation of equalities (4.5) we become informed that there is no retardation of the moving clock being at rest in the point  $x' = 0$  with respect to the stationary clocks being at rest in the points of unprimed IRF.

**The fifth** essential dissimilarity of the new theory from Einstein's SRT consists in dependence of electric charge value of a moving body or a particle on the value of that body or a particle speed of motion. This dependence has the form:

$$q_u = \frac{q_0}{\gamma}, \quad (4.6)$$

where  $q_u$  is the electric charge of a particle or a body, moving at the speed  $u$ ;

$q_0$  is the electric charge of the stationary particle or the body (moving at the speed  $u = 0$ ),

$$\gamma = \frac{1}{\sqrt{1-\beta^2}} = \sqrt{1+\frac{u^2}{c_0^2}} \text{ is the relativistic factor.}$$

## V. DEPENDENCE OF PARTICLE ELECTRIC CHARGE UPON PARTICLE SPEED

The new space-time theory [6 p. 10] basing upon transformations (3.9) - (3.10) essentially differs from the Einstein's SRT. One of main essential differences of the NRSTT from Einstein's SRT consists in dependence of the moving particle electric charge upon value of this particle movement speed. This dependence has the form:

$$q_u = \frac{q_0}{\gamma}, \quad (5.1)$$

where  $q_u$  is the electric charge value of a particle moving at the speed  $u$ ;  $q_0$  is the electric charge value of an immovable particle

$$\gamma = \frac{1}{\sqrt{1-\beta^2}} = \sqrt{1+\frac{u^2}{c_0^2}}, \quad \beta = \frac{u}{c_u}. \quad (5.2)$$

Really, having used in the primed stationary IRF the Maxwell's equations

$$\text{rot}'\vec{H}' = \vec{j}' + \frac{\partial \vec{D}'}{\partial t'}; \quad (5.3.1)$$

$$\text{div}'\vec{D}' = \rho'; \quad (5.3.2)$$

$$\text{rot}'\vec{E}' = -\frac{\partial \vec{B}'}{\partial t'}; \quad (5.3.3)$$

$$\text{div}'\vec{B}' = 0, \quad (5.3.4)$$

where  $\vec{D}'$ ,  $\vec{B}'$  are vectors of electric field inductance and magnetic field inductance in the primed stationary IRF;  $\vec{E}'$ ,  $\vec{H}'$  are vectors of electric field strength and magnetic field strength in the primed stationary IRF;  $\rho'$  is the electric charge density in the primed stationary IRF,  $\vec{j}'$  is the vector of current density in the primed stationary IRF, the transformations (3.9) – (3.10), we shall obtain Maxwell's equations in unprimed moving IRF

$$\text{rot}\vec{H} = \vec{j} + \frac{\partial \vec{D}}{\partial t}; \quad (5.4.1)$$

$$\text{div}\vec{D} = \rho; \quad (5.4.2)$$

$$\text{rot}\vec{E} = -\frac{\partial \vec{B}}{\partial t}; \quad (5.4.3)$$

$$\text{div}\vec{B} = 0, \quad (5.4.4)$$

where  $\vec{D}$ ,  $\vec{B}$  are vectors of electric field inductance and magnetic field inductance in unprimed moving IFR;  $\vec{E}$ ,  $\vec{H}$  are vectors of electric field strength and magnetic field strength in unprimed moving IRF,  $\rho$  is the density of electric charge in the unprimed moving IRF;  $\vec{j}$  is the current density vector in the unprimed IRF, and between field parameters in two IRF moving each with respect the other there are the following dependences:

$$c_u D_x = c_0 D'_x; \quad (5.5.1)$$

$$c_u D_y = \gamma(c_0 D'_y + \beta H'_z); \quad (5.5.2)$$

$$c_u D_z = \gamma(c_0 D'_z - \beta H'_y); \quad (5.5.3)$$

$$E_x = E'_x; \quad (5.5.4)$$

$$E_y = \gamma(E'_y + \beta c_0 B'_z); \quad (5.5.5)$$

$$E_z = \gamma(E'_z - \beta c_0 B'_y); \quad (5.5.6)$$

$$c_u B_x = c_0 B'_x; \quad (5.5.7)$$

$$c_u B_y = \gamma(c_0 B'_y - \beta E'_z); \quad (5.5.8)$$

$$c_u B_z = \gamma(c_0 B'_z + \beta E'_y); \quad (5.5.9)$$

$$c_u \rho = \gamma(c_0 \rho' + \beta j'_x); \quad (5.5.10)$$

$$j_x = \gamma(j'_x + \beta c_0 \rho'); \quad (5.5.11)$$

$$j_y = j'_{y'}; \quad (5.5.12)$$

$$j_z = j'_{z'}, \quad (5.5.13)$$

where  $\beta = \frac{u}{c_u}, \gamma = \frac{1}{\sqrt{1-\beta^2}}$ .

From the expression (5.5.10) at  $j'_x = 0$  we shall have

$$\rho = \rho', \quad (5.6)$$

i.e. according to the NRSTT at absence of longitudinal current in a stationary primed IRF the electric charge density is an invariant value.

But the electric charge densities in two IRF moving each with respect the other uniformly and rectilinearly at absence of longitudinal current in the stationary IRF are determined by the expressions

$$\rho = \frac{q_u}{\Omega_u}; \rho' = \frac{q_0}{\Omega_0}, \quad (5.7)$$

where  $q_u$  is the value of a particle charge moving at the speed  $u$ ;  $q_0$  is the value of a stationary particle charge;  $\Omega_0$  is the volume of the charge in a stationary IRF;

$$\Omega_u = \frac{\Omega_0}{\gamma} \quad (5.8)$$

is the volume occupied by the charge in a moving IRF.

Having substituted now formulas (5.7) and (5.8) into the formula (5.6) we shall have the formula of particle charge dependence upon particle speed in the new relativistic space-time theory in the form

$$q_u = \frac{q_0}{\gamma} \quad (5.9)$$

that coincides with the formula (5.1) at

$$\gamma = \frac{1}{\sqrt{1-\beta^2}} = \sqrt{1+\frac{u^2}{c_0^2}}. \quad (5.10)$$

Thus, in the NRSTT the more is the speed of a charged particle, the less is its electric charge.

## VI. NEW RELATIVISTIC PARTICLE DYNAMICS

Let us consider an elementary particle with electrical charge  $e_0$  and invariant mass  $m$  at a certain time moment resting in the primed inertial reference frame (IRF) B, that is moving at a Galilean speed  $u$  in the positive direction of the axis X of unprimed IRF A. Let this particle be in the electromagnetic field, which source is at rest in the IRF B. Then we can suppose that motion of this particle in the IRF B takes place further in accordance with equations

$$m \frac{d^2 x'}{dt'^2} = e_0 E'_x; \quad (6.1)$$

$$m \frac{d^2 y'}{dt'^2} = e_0 E'_y;$$

$$m \frac{d^2 z'}{dt'^2} = e_0 E'_z;$$

where

$$E'_x = E_x;$$

$$E'_y = \gamma(E_y - \beta c_0 B_z); \quad (6.2)$$

$$E'_z = \gamma(E_z + \beta c_0 B_y);$$

$E'_x, E'_y, E'_z$  are the components of the electric field strength vector, acting onto this elementary particle, being at rest in the IRF B;  $E_x, E_y, E_z, B_y, B_z$  are components of the electric field vector and the component parts of magnetic field inductance vector, measured in the IRF A – in that point of the IRF A, in which the particle under consideration is situated at any given time moment.

At that expressions (6.2) are obtained similarly to equations (5.5.4), (5.5.5) and (5.5.6) for electromagnetic field, which source is at rest in the unprimed IRF.

Having substituted expressions (6.2) into equations (6.1), we obtain

$$m \frac{d^2 x'}{dt'^2} = e_0 E_x;$$

$$m \frac{d^2 y'}{dt'^2} = e_0 \gamma (E_y - \beta c_0 B_z); \quad (6.3)$$

$$m \frac{d^2 z'}{dt'^2} = e_0 \gamma (E_z + \beta c_0 B_y).$$

In the right parts of equations (6.1) and (6.3) the forces are placed, acting on the elementary particle with an electric charge  $e_0$ , which is at rest in the IRF B. Therefore in these equations the formula of electric charge dependence upon speed is not used. At that in the right parts of equations (6.3) the forces acting on the particle in the IRF B are expressed using components of electromagnetic field vectors measured in the IRF A.

Let us express the left parts of equations (6.3) using coordinates and time measured in IRF A. For that purpose let us use transformation (4.4) from section 4 (as we consider events, taking place in the stationary IRF B):

$$c_0 \cdot t' = \gamma \cdot (c_u \cdot t - \beta \cdot x), \quad x' = \gamma \cdot (x - \beta \cdot c_u \cdot t), \quad y' = y, \quad z' = z, \quad (4.4)$$

where  $\beta = \frac{u}{c_u}$ ,  $\gamma = \frac{1}{\sqrt{1-\beta^2}}$ ,  $c_u = \sqrt{c_0^2 + u^2}$ .

Having twice differentiated each of two first equations of transformation (4.4) by time  $t'$  and having substituted into the resulting expressions (after differentiation) the values

$$dx/dt = u, \quad dy/dt = 0, \quad dz/dt = 0,$$

we have

$$\frac{d^2 x'}{dt'^2} = \gamma \cdot \frac{d^2 x}{dt^2}; \quad \frac{d^2 y'}{dt'^2} = \frac{d^2 y}{dt^2}; \quad \frac{d^2 z'}{dt'^2} = \frac{d^2 z}{dt^2}. \quad (6.4)$$

Now let us substitute expressions (6.4) into left parts of equations (6.3). We shall obtain instead of (6.3)

$$m\gamma \frac{d^2 x}{dt^2} = e_0 E_x; \quad m \frac{d^2 y}{dt^2} = e_0 \gamma (E_y - \beta c_0 B_z); \quad m \frac{d^2 z}{dt^2} = e_0 \gamma (E_z + \beta c_0 B_y); \quad (6.5)$$

where, as before,

$$\beta = \frac{u}{c_u}, \quad \gamma = \frac{1}{\sqrt{1-\beta^2}}, \quad c_u = \sqrt{c_0^2 + u^2}.$$

If  $E_z$  and  $B_y$  are the only components of the electromagnetic field not equal to zero, then from expressions (6.5) only the last one will remain

$$\frac{d^2 z}{dt^2} = \frac{e_0 \gamma}{m} (E_z + \beta c_0 B_y). \quad (6.6)$$

Bending of the particle motion trajectory under action of this deflection field takes place in the plane  $xz$  and trajectory curvature radius  $R$  can be determined from the formula

$$\frac{u^2}{R} = \frac{d^2 z}{dt^2}. \quad (6.7)$$

If only the magnetic field with inductance  $B_y$  is present, from equations (6.6) and (6.7) we shall obtain an expression for particle trajectory curvature radius in the transversal magnetic field

$$R_M = \frac{m u}{e_0 B_y}. \quad (6.8)$$

If only the electric field with the strength  $E_z$  is present, from equations (6.6) and (6.7) we shall obtain an expression for the particle trajectory curvature radius in the transversal electric field

$$R_E = \frac{m u^2}{e_0 \gamma E_z}. \quad (6.9)$$

In the special relativity theory (SRT) the analogs for formulas (6.8) and (6.9) will be the formulas

$$R_M^{SRT} = \frac{m V}{e_0 B_y \sqrt{1-V^2/c_0^2}}, \quad (6.10)$$

$$R_E^{SRT} = \frac{m V^2}{e_0 E_z \sqrt{1-V^2/c_0^2}}, \quad (6.11)$$

where  $V$  is the particle motion speed in accordance with the SRT, not exceeding the constant  $c_0$ .

From expressions (6.8) and (6.9) we obtain

$$\frac{R_E}{R_M} = \frac{B_y}{E_z} \frac{u}{\sqrt{1+u^2/c_0^2}}. \quad (6.12)$$

And from expressions (6.10) and (6.11) we obtain

$$\frac{R_E^{SRT}}{R_M^{SRT}} = \frac{B_y}{E_z} V. \quad (6.13)$$

The formula (6.12) from the new space-time theory coincides with the formula (6.13) from the SRT, if between "V-speed" from the SRT and "u-speed" from the new theory the following dependence exists

$$V = \frac{u}{\sqrt{1+u^2/c_0^2}}. \quad (6.14)$$

If only the longitudinal electric field with the strength  $E_x$  is present, then from equations (6.5) only the first expression will remain, that could be rewritten in the form

$$m c_0^2 \gamma^3 \frac{d^2 x}{d(c_u t)^2} = e_0 E_x. \quad (6.15)$$

Let the particle with the charge  $e_0$  and the mass  $m$  be initially at rest in the coordinates origin of the IRF A. At a certain time moment an accelerating electrostatic field becomes acting, which source is at rest in the IRF A, and at that the vector of electrostatic field acting upon the particle is parallel to the axis X of the IRF A. Then on the infinitesimally small section of path  $dx$ , within which the particle acceleration can be considered constant, the particle will take from the electrostatic field the following energy

$$dW = e_0 E_x dx. \quad (6.16)$$

Having substituted into the right part of the expression (6.16) instead of the expression  $e_0 E_x$  an expression from equation (6.15) equal to it, then we shall obtain

$$dW = m c_0^2 \gamma^3 \frac{d^2 x}{c_u^2 \cdot dt^2} dx. \quad (6.17)$$



But in the expression (6.17) it is possible to perform the following transformations, considering the value  $C_u$  as a constant one

$$\frac{d^2x}{c_u^2 \cdot dt^2} \cdot dx = \frac{d\left(\frac{dx}{dt}\right)}{c_u^2 \cdot dt} \cdot dx = \frac{1}{c_u^2} \frac{dx}{dt} d\left(\frac{dx}{dt}\right) = \frac{1}{c_u^2} u du = \beta d\beta, \quad (6.18)$$

where  $\beta = u / c_u$ . That is why the expression (6.16) can be written in the form

$$dW = m c_0^2 \gamma^3 \beta d\beta. \quad (6.19)$$

The full energy, taken by the particle from the electrostatic field and converted into the kinetic energy of the particle, we can obtain if we shall perform integration of the expression (6.19) within the limits from zero to  $\beta$

$$W = \int_0^\beta m c_0^2 \gamma^3 \beta d\beta. \quad (6.20)$$

Having performed the integration, we obtain

$$W = m c_0^2 \left( \frac{1}{\sqrt{1-\beta^2}} - 1 \right). \quad (6.21)$$

The dependence (6.21) appearance of the particle kinetic energy upon the speed of its motion in the new space-time theory coincides with the similar dependence from the SRT. But in the formula (6.21) of the new theory the value  $\beta$  is determined by the formula

$$\beta = \frac{u}{c_u} = \frac{u/c_0}{\sqrt{1+u^2/c_0^2}}, \quad (6.22)$$

while in the SRT the same value  $\beta$  is determined by the formula

$$\beta = \frac{V}{c_0}. \quad (6.23)$$

Though, if we shall insert the expression (6.14) into the formula (6.23), we shall obtain the formula (6.22). Consequently, taking into account the formula (6.14) the dependence (6.21) of the particle kinetic energy upon motion speed in the new space-time theory coincides with the similar dependence from the SRT. But having substituted the formula (6.22) into the formula (6.21), we obtain

$$W = m c_0^2 \left( \sqrt{1+u^2/c_0^2} - 1 \right). \quad (6.24)$$

Then, if we as earlier shall consider, that

$$E_0 = m c_0^2 \quad (6.25)$$

is the rest energy of the particle, then the formula (6.24) can be interpreted as a difference between the full particle energy

$$E = m c_0^2 \sqrt{1+u^2/c_0^2} \quad (6.26)$$

and the particle rest energy (6.25).

After squaring the both parts of the equation (6.26) we obtain the expression

$$E^2 = m^2 c_0^4 + m^2 u^2 c_0^2, \quad (6.27)$$

which can be considered as a relation between the full energy of the particle and its momentum in the new space-time theory

$$E^2 = m^2 c_0^4 + p^2 c_0^2, \quad (6.28)$$

where  $p = m u$  (6.29)

is the particle momentum in the new space-time theory.

Having substituted into the formula (6.29) the expression  $u = \frac{V}{\sqrt{1-V^2/c_0^2}}$ , which can be obtained if

we shall solve the equation (6.14) with respect to the value  $u$ , we obtain the formula

$$p = \frac{m V}{\sqrt{1-V^2/c_0^2}}, \quad (6.30)$$

which determines the particle momentum in the SRT.

Having solved the expression (6.24) with respect to the particle speed, we obtain dependence of the particle speed upon its kinetic energy in the new space-time theory

$$\frac{u}{c_0} = \sqrt{\left( \frac{W}{m c_0^2} + 1 \right)^2 - 1}. \quad (6.31)$$

From this formula it follows that if the particle kinetic energy exceeds 42% from its rest energy, then such a particle must move at a superlight speed.

Having submitted the formula (6.31) into the formula (6.8), we obtain dependence of charged particle radius of curvature in the transversal magnetic field upon kinetic energy of the particle, which is valid in the new space-time theory

$$R_M = \frac{m c_0^2}{e_0 B_y} \sqrt{\left( \frac{W}{m c_0^2} + 1 \right)^2 - 1}. \quad (6.32)$$

This dependence coincides completely with the similar dependence from the SRT – the dependence, determining operation of the cyclic particle accelerators. The dependence (6.32) can be also converted to a form

$$R_M = \frac{\sqrt{W(W + 2E_0)}}{c_0 e_0 B_y} \quad (6.33)$$

Thus, from the new space-time theory it follows, that if the kinetic energy of the particle exceeds 42% from the rest energy of the particle, then the particle moves at the superlight speed.

But in modern particle accelerators we long ago have encountered with particle kinetic energies, sufficiently exceeding the particles rest energies. And, nevertheless, superlight speeds in experiments on particle accelerators are not detected till now. This fact can be considered as the basis for statement that new space-time theory is not confirmed by operation of modern particle accelerators. But before we shall agree with these statement, let us clarify, whether we really do not detect superlight speeds on particle accelerators, or we do not wish to see them because these superlight speeds are prohibited by the SRT.

## VII. HOW THE MOUNTAIN HAS BROUGHT FORTH A MOUSE

Now let us consider the consequences of the formula (6.31) on the operation of the Large Hadron Collider (LHC). The appearance of this formula is such

$$\frac{u}{c_0} = \sqrt{\left(\frac{W}{mc_0^2} + 1\right)^2} - 1 \quad (7.1)$$

The rest energy of an electron is equal to approximately 0.511 MeV, and the rest energy of a proton is approximately equal to 938 MeV. According to the formula (7.1) if an electron has a kinetic energy greater than  $0.42 \times 0.511 \text{ MeV} = 0.22 \text{ MeV}$  it moves at a superlight speed. And a proton moves at a superlight speed, if its kinetic energy is greater than  $0.42 \times 938 \text{ MeV} = 394 \text{ MeV} = 3.94 \cdot 10^8 \text{ eV}$ .

But it is declared now that kinetic energy of protons in the LHC is equal to approximately  $W = 7 \text{ TeV} = 7 \cdot 10^{12} \text{ eV}$ .

Let us determine using the formula (7.1) at what speed must the proton move in order to have the kinetic energy of 7 TeV. If  $W=7 \text{ TeV}$ ,  $mc^2=394 \text{ MeV}$ , we shall

obtain from the formula (7.1) the value  $\frac{u}{c_0} \approx 7464$ .

Who is a liar, the author of this article or every of today's (I don't dare saying "modern") physicists, who believe that the speed of any proton in the LHC does not exceed the speed of light in vacuum of a stationary IRF?

Let us solve the equation (7.1) with respect to a ratio of the particle kinetic energy to the particle rest energy. We shall obtain the formula

$$\frac{W}{m c_0^2} = \sqrt{1 + \frac{u^2}{c_0^2}} - 1 \quad (7.2)$$

Both from (7.1) and from (7.2) it follows that approximate equation between the values  $W/mc_0^2$  and  $u/c_0$  is such

$$\frac{W}{m c_0^2} \approx \frac{u}{c_0} \quad (7.3)$$

But the modern physicists, when performing acceleration of protons, more likely strive to reach the speed of light  $c_0$  than to exceed it (because in accordance with Einstein's SRT it is impossible to exceed the speed of light), then according to the exact formula (7.2) the proton kinetic energy in this case will not exceed the value of  $0.414 \times E_0 < 400 \text{ MeV}$ .

The proton beam in the LHC (that is the greatest circular accelerator with circumference length equal approximately to 27 km) exists during approximately some tens of hours. Protons in this beam move at the speed approximately equal to the speed of light in vacuum  $c_0$  having kinetic energy not greater than 400 MeV at any time moment. Then, what great discoveries can be made on such an accelerator? In this case we can say "The mountain LHC has brought forth a mouse (a proton)" with kinetic energy not exceeding 400 MeV. They (today's physicists) declare that kinetic energy of any of accelerated protons in LHC is equal to 7 TeV. But new space-time theory that is discussed in this article proves that real kinetic energy of any of accelerated protons in LHC does not exceed the energy of 400 MeV. So, according to NRSTT it is a greatest lie in the history, that any proton in the LHC after its acceleration approximately to the speed of light  $c_0$  has the kinetic energy equal to 7 TeV.

## VIII. EXPERIMENT BY NEDDERMEYER AND ANDERSON IN 1938 AS A GRANDIOSE CONFIRMATION OF SUPERLIGHT SPEEDS AND DEPENDENCE OF CHARGE UPON SPEED EXISTENCE IN NATURE

It is considered now, that in the article by Neddermeyer S.H., Anderson C.D. titled "Cosmic-ray particles of intermediate mass". // Physical Review. 1938. [7, p.88] the particles were discovered with mass intermediate between the mass of a proton and a mass of an electron. In experiments with Wilson chamber placed in the magnetic field described in this article of 1938, its authors showed, that high-energy particles from consist of space particles penetrated through considerably large layers of heavy substance (plumbum, platinum, copper), losing the energy only on ionization of substance atoms. Identification of these particles, having high penetration capability, with protons, which mass was by a factor of 1936 times greater than the mass of an electron, seemed to be impossible. Because if the particle had the mass of a proton, then its speed

calculated on the curvature radius of the particle trajectory in the transversal magnetic field, should result in such ionization of gas along the particle trajectory in Wilson chamber, that tenfold times was greater than the ionization really observed in experiments.

On the other hand, it was impossible to identify these particles, having high penetration capability, before appearance of the new space-time theory, discussed in this article, with electrons. Because from theoretical calculations based upon the SRT, it followed that high-energy electrons should lose the major part of their energy on braking radiation. But the particles possessing high penetration capability should not have noticeable losses of energy on braking radiation (otherwise they should not possess high penetration capability).

In the new relativistic space-time theory there is an alternative approach to solving a problem of muon-electron universality. This approach is based upon the property of an electric charge dependence upon speed, existing in the NRSTT. This dependence has the form (see section 4)

$$e_u = \frac{e_0}{\gamma}, \quad (8.1)$$

where  $e_0$  is electrical charge of a stationary particle;

$e_u$  is electrical charge of a particle moving at the speed  $u$ ;

$$\gamma = \frac{1}{\sqrt{1-\beta^2}} = \sqrt{1+\frac{u^2}{c_0^2}}$$
 is the relativistic factor;

$u$  is the speed of a particle motion.

Indeed, in the new relativistic space-time theory the formula for losses of particle energy on braking radiation (bremsstrahlung radiation) taking into account the minimal value of impact parameter resulting from quantum theory has the form

$$-\frac{dE}{dx} = \frac{\pi N (z e_0)^2 e_u^4}{3 E_0 \hbar \left(\frac{u}{c_0}\right)}, \quad (8.2)$$

where  $dE/dx$  are losses of a particle energy along 1 cm of the path through some substance because of braking (bremsstrahlung) radiation during its motion through some substance;

$N$  is the number of atomic nuclei in 1 cm<sup>3</sup> of substance;

$z e_0$  is the charge of one atomic nucleus ( $z$  is number of protons in one atomic nucleus);

$E_0 = m c_0^2$  is the energy of one resting particle emitting the breaking radiation;

$m$  is an invariant mass of that particle;

$\hbar$  is the Plank's constant;

$u$  is the Galilean speed of a particle motion;

$e_u$  is the charge of a particle moving at the speed  $u$  included in the formula (8.1);

$c_0$  is the speed of light in vacuum of immovable IRF.

If a particle moves at a very high superlight speed (if  $u \gg c_0$  from the formula (8.1) we have

$$e_u \approx e_0 / (u / c_0). \quad (8.3)$$

Then having substituted the expression (8.3) into the formula (8.2), we shall obtain the formula

$$-\frac{dE}{dx} = \frac{\pi N z^2 e_0^6}{3 E_0 \hbar \left(\frac{u}{c_0}\right)^5}, \quad (8.4)$$

in accordance with which at increase of the superlight speed of a particle motion by one order (at 10 times increase) the particle losses because of braking radiation will decrease by five orders (decrease by 10<sup>5</sup> times). As a consequence of such a formula the braking radiation for high energy positrons or electrons (moving at speeds sufficiently exceeding the speed of light in vacuum of a stationary IRF  $c_0$ ) becomes considerably lesser, than the braking radiation of low energy electrons. This allows identifying cosmic ray particles in K. Anderson and S. Nedderamyer experiment in 1938 [7, p.88], having high penetration capability, as high-energy positrons moving at superlight speed, which electrical charge was sufficiently decreased because of particle charge dependence upon particle speed of motion. Thus the experiment [7] can be interpreted as experimental confirmation of both particle movement at superlight speeds and as experimental confirmation of electrical charge value dependence upon the particle speed value.

For example, as in accordance with the NRSTT the speed of an electron or a positron can be determined using the formula,

$$\frac{u}{c_0} = \frac{BR e_0}{m c_0}, \quad (8.5)$$

where  $B$  is the magnetic field inductance,  $R$  is the radius of a positron trajectory,  $e_0$  is electrical charge of a stationary positron, the speed of a positron in the upper part of a photographic picture shown in the article [7, p. 88] is 100 times greater than the light speed  $c_0$ , and the positron speed in the lower part of this picture is 14 times greater than the speed of light  $c_0$ .

## IX. CONCLUSIONS

The results of my research in the field of creating a new space-time theory basing upon not three, but only two principles are as follows.



1. Einstein's second postulate (independence of light speed upon speed of light source) comes into a contradiction with the relativity postulate, the most evident argument in support of this statement is non-equality of time measurement units of a moving light clock (MLC) and a stationary light clock (SLC) having identical design. It is well seen from the formula for MLC time measurement unit

$$T_{MLC} = \frac{L_0}{\gamma} \left( \frac{1}{c_0 - V} + \frac{1}{c_0 + V} \right) = \gamma T_{SLC}, \text{ where } \gamma = \frac{1}{\sqrt{1 - V^2/c_0^2}}$$

is a Lorentz factor;  $T_{SLC} = \frac{2L_0}{c_0}$ ;  $L_0$  is a distance between parallel mirrors of the stationary light clock;  $V$  is the Lorentzian speed of motion that cannot exceed the value of speed of light in vacuum of a stationary IRF  $c_0 = 299\,792\,458$  m/s. Namely this inequality ( $T_{MLC} \neq T_{SLC}$ ) is the physical cause of time dilation effect in Einstein's SRT.

2. A new relativistic space-time theory (NRSTT) basing upon only two postulates can be created. In this new space-time theory the equality  $T_{MLC} = T_{SLC}$  is provided by means of introduction into the theory of the new concept "speed of light in vacuum of a moving IRF" that is defined according to the formula  $c_u = \sqrt{c_0^2 + u^2}$ , where  $u$  is the Galilean speed of motion that can vary from zero to infinity. The equality of time measurement units in the MLC and the SLC is provided because of equalities  $c_u = \gamma c_0$ ,

$$c_u^2 - u^2 = c_0^2 \quad \text{and} \quad \gamma = \frac{1}{\sqrt{1 - V^2/c_0^2}} = \sqrt{1 + u^2/c_0^2}$$

providing the validity of such consequence of equalities

$$T_{MLC} = \frac{L_0}{\gamma} \left( \frac{1}{c_u - u} + \frac{1}{c_u + u} \right) = \frac{L_0}{\gamma} \frac{2c_u}{c_u^2 - u^2} = \frac{L_0}{\gamma} \frac{2\gamma c_0}{c_0^2 + u^2 - u^2} = T_{SLC}$$

3. The formulas for connection between Galilean and Lorentzian speeds of motion have the forms

$$u = \frac{V}{\sqrt{1 - \frac{V^2}{c_0^2}}}, \quad V = \frac{u}{\sqrt{1 + \frac{u^2}{c_0^2}}}$$

4. The space-time co-ordinates transformation in the new theory has the form

$$c_u t = \frac{c_0 t' + \beta x'}{\sqrt{1 - \beta^2}}, \quad x = \frac{x' + \beta c_0 t'}{\sqrt{1 - \beta^2}}, \quad y = y', \quad z = z',$$

where  $\beta = \frac{u}{c_u}$ ,  $c_u = \sqrt{c_0^2 + u^2}$ . The superlight speeds of bodies and particles are not forbidden in the NRSTT because relativistic roots in the denominators of transformations never can become imaginary numbers.

Having put a clock in the point  $x' = 0$  of the primed IRF and substituting this equality  $x' = 0$  into equations  $c_u t = \frac{c_0 t' + \beta x'}{\sqrt{1 - \beta^2}}$ ,  $x = \frac{x' + \beta c_0 t'}{\sqrt{1 - \beta^2}}$  we shall obtain

the equations  $t = t'$ ,  $x = u \cdot t$ , from which it is well seen that time dilation is absent in the NRSTT.

5. Having applied transformations of the NRSTT to Maxwell's equation we shall obtain that in the NRSTT there is the dependence of a moving particle electric charge upon its speed of motion in the form  $q_u = \frac{q_0}{\gamma}$ , where  $q_u$  is the electric charge of a particle, moving at the speed  $u$ ;  $q_0$  is the electric charge of the stationary particle,  $\gamma = \frac{1}{\sqrt{1 - \beta^2}} = \sqrt{1 + \frac{u^2}{c_0^2}}$  is the relativistic factor.

6. The dependence of any particle speed upon the kinetic energy of that particle in the NRSTT has the form  $\frac{u}{c_0} = \sqrt{\left( \frac{W}{m c_0^2} + 1 \right)^2} - 1$ , where  $W$  is the particle

kinetic energy. From this formula it follows that if kinetic energy of the particle exceeds 42% of its rest energy  $E_0 = m c_0^2$ , then this particle moves at a superlight speed.

7. The dependence (6.32) of charged particle radius upon kinetic energy of the particle in the NRSTT

$$R_M = \frac{m c_0^2}{e_0 B_y} \sqrt{\left( \frac{W}{m c_0^2} + 1 \right)^2} - 1$$

coincides with the same dependence in Einstein's SRT. Therefore operation of cyclic particle accelerators is well described both by the SRT and the NRSTT.

8. Because of Einstein's prohibition of superlight speeds in the SRT the statement of this research about movement of high-energy particles at superlight speeds seems to be a lie of an amateur. But future can confirm this statement and the earlier this statement will be tested in practice, the earlier it will become clear, who now is a scientific researcher and who is a freak or an idiot.

9. If superlight speeds of high-energy particles exist in nature, then many of physical experiments performed in past years must be reinterpreted from point of view of the NRSTT.

10. The experiment by Neddermayer S.H. and Anderson C.D. [7, p. 88] is the first experiment from physics history, which should be reinterpreted.

11. In accordance with the formula (7.1) from the NRSTT having the form  $\frac{u}{c_0} = \sqrt{\left( \frac{W}{m c_0^2} + 1 \right)^2} - 1$  any

proton with kinetic energy  $W > 394$  MeV moves at a speed greater than  $c_0$ . But now Einstein's SRT is considered to be true and in all particle accelerators

(in LHC too) physicists strive to accelerate particles not to superlight speeds (which are considered to be antiscientific) but only to the speed, which value does not exceed the speed of light in vacuum of a stationary IRF  $c_0$ . And as according to the NRSTT a proton moving at a speed equal to  $c_0$  has the kinetic energy equal only to the value 394 MeV, then we must consider that statement about achieving by accelerated in LHC protons the energy of 7 TeV is a simple lie.

The physical cause of such lie consists in the fact that now all physicists consider the Lorentzian speed  $V$  of particles motion, which is included in the Lorentz transformation, as a physically measured speed. In accordance with the NRSTT the real physically measured speed is equal to Galilean speed  $u$  connected with the Lorentzian speed by the equations

$$u = \frac{V}{\sqrt{1 - \frac{V^2}{c_0^2}}}, \quad V = \frac{u}{\sqrt{1 + \frac{u^2}{c_0^2}}}, \quad \text{where } u \text{ is the Galilean}$$

speed of motion,  $V$  is the Lorentzian speed of motion.

12. In connection with the fact that Einstein's SRT is a self-contradictory theory (it was shown also here [8, p. 91]) and is an anti-scientific one, it is necessary to perform re-appreciation of all experiments made during latest 110 years and to cancel study of Einstein's theories (as erroneous) in schools and universities.

## X. ACKNOWLEDGMENTS

I am grateful to reviewers for their contributions to improve the paper.

## REFERENCES RÉFÉRENCES REFERENCIAS

1. Einstein A., On Electrodynamics of moving bodies, June 30, 1905, [url]<http://www.fourmilab.ch/etexts/einstein/specrel/www/>[/url].
2. Mamaev A.V. Replacement of Einstein's Relativity Theory with a New One: Why the Second Postulate is Superfluous? International Journal of Physics. vol.4, No. 5 (2016), pp. 140-145 2016, [url]<http://www.sciepub.com/ijp/content/4/5>[/url] See also [url]<http://vixra.org/abs/1410.0148> [/url].
3. Logunov A.A. Lectures on theory of relativity and gravitation. Modern analysis of the problem. M.: Nauka, 1987, p. 33 – 35
4. Mamaev A.V. "Astronomical phenomena disprove Einstein's Special Relativity Theory, "The Way of Science"/ 2014. No.5 (5). p.p. (10-19). [img]<http://vixra.org/pdf/1410.0148v1.pdf>[/img]
5. [url]<http://gingadan.com/iras05437.html>[/url]
6. Mamaev A.V. New Relativistic Space-Time Theory. "The Way of Science"/ 2014. No.1 (1), p.p. 10-84. (In Russian). [url]<http://scienceway.ru/d/706321/d/the-way-of-science--1-%281%29-march.pdf> [/url]

7. Neddermeyer S.H., Anderson C.D. Cosmic-ray particles of intermediate mass. // Physical Review. - 1938. - v.54. - p. 88 - 89. URL: <http://bolshoyforum.com/forum/index.php?topic=426616.msg5520307#msg5520307>
8. Mamaev A.V. New Relativistic Space-Time Theory. International Congress-2016 "Fundamental Problems of Natural Sciences and Engineering", Saint Petersburg. July 25-30 2016. In a book "Congress-2016 Proceedings" Issue 37-2, p.p. 91-122 (In Russian). [url] <http://scicom.ru/files/journal/v37/N2/12.pdf>[/url]

This page is intentionally left blank



## Fluids through Inclined Granular Media

By A .T. Ngiangia & Sozo T Harry

*University of Port Harcourt*

**Abstract-** A theoretical analysis of inclined fluids through granular media was carried out. Modified Darcy's equation and its approximate solution showed that for the isothermal case, increase in the argument and permeability of the granules result in a corresponding increase in the pressure exerted on the photosphere while increase in porosity and viscosity brings about a decrease in the pressure. For the adiabatic fluid case, the pressure is not affected as a result of increase in the angle of the granules. The same physical results occur in both the isothermal fluid case and that of the adiabatic fluid case as a result of increase in viscosity, porosity and permeability of the granules in the pressure exerted on the photosphere.

**Keywords:** granules, isothermal, adiabatic, photosphere, darcy's equation, taylor's series expansion.

**GJSFR-A Classification:** FOR Code: 020303



*Strictly as per the compliance and regulations of :*



# Fluids through Inclined Granular Media

A .T. Ngiangia <sup>α</sup> & Sozo T Harry <sup>σ</sup>

**Abstract-** A theoretical analysis of inclined fluids through granular media was carried out. Modified Darcy's equation and its approximate solution showed that for the isothermal case, increase in the argument and permeability of the granules result in a corresponding increase in the pressure exerted on the photosphere while increase in porosity and viscosity brings about a decrease in the pressure. For the adiabatic fluid case, the pressure is not affected as a result of increase in the angle of the granules. The same physical results occur in both the isothermal fluid case and that of the adiabatic fluid case as a result of increase in viscosity, porosity and permeability of the granules in the pressure exerted on the photosphere.

**Keywords:** granules, isothermal, adiabatic, photosphere, darcy's equation, taylor's series expansion.

## I. INTRODUCTION

Look into the atmosphere at the surface of the sun appears completely opaque at a point called the photosphere. It is regarded as an imaginary surface from which the solar light appears to be emitted. Photosphere is the densest level of the solar atmosphere with a high temperature of not less than  $5510^0 C$  [1]. It is a star's outer shell from which light is radiated and a pressure of about the fraction 0.001 that of earth's atmosphere at sea level. The photosphere as a negative hydrogen ions, block, absorb and emit light, all of which prevent light from passing directly through a cloud of hydrogen ions. As a result of convection currents, pressure is exerted continuously on the photosphere and it breaks into tiny bright points called granules. The granules are in constant turmoil and change as a result of pressure exerted on the photosphere of the sun caused by convection currents of plasma within the sun's convection zone. The flow within the granules can reach supersonic speed and generates waves on the sun surface, at this level, the Navier-Stokes equation would be an appropriate equation to model the physical condition. Ulysses spacecraft and the Solar and Heliospheric Observatory (SOHO) of the United States and European Space Agency which was launched in 1990 and 1995 respectively, has jointly contributed to the understanding of solar wind in regions above the sun poles. Fluid flow through granular medium and its attendant effect forms the core for the study of astrophysics and its sub

disciplines. There has been studies and many ongoing on the porosity, permeability, viscosity and its attendant effect on flow of fluid and this has necessitated the use of Darcy's equation and its modification in the study of these myriads of problems. [2] and [3] considered anthropogenic and non anthropogenic factors on the depletion of the ozone layer. They deduced that reaction of fluids mainly gases led to its depletion. [4], critically analyzed the seepage of polar fluids through porous media and deduced that, permeability and porosity are causes of the change in the pressure of the fluid. [5], examined porosity and permeability using modeling and strongly describe the existence of correlation between grain size and hydraulic conductivity.[6-11], specifically mentioned porous medium as the plank of their study and their recommendation greatly enrich the study of fluids through porous media. [12], considered the effect of fluid salinity on permeability of oil reservoir and opined that, increase concentration of fluid salinity, enhanced the recovery of core contents as a result of increased permeability. Measurement of flow material in the photosphere can be tackled using the principle of Doppler Effect. These measurements reveal additional features such as super granules, large scale flows and pattern of waves and oscillations. However, our aim is to theoretically examine the pressure of the fluid through an inclined granules and when it is not as a result of the effect of viscosity, porosity and permeability.

## II. FORMALISM

For flow of fluid through porous medium, the smoothed continuity equation and the Darcy's equation respectively are

$$\xi \frac{\partial \rho}{\partial t} = -(\nabla \cdot \rho v_0) \quad (1)$$

$$v_0 = -\frac{\kappa}{\mu} (\nabla p - \rho g \cos \varphi) \quad (2)$$

where  $\xi, \kappa, \rho, \mu, v_0, p, t, g, \varphi$  are respectively the porosity, permeability, density of fluid, fluid viscosity, superficial velocity, pressure of fluid, time, acceleration due to gravity and argument. Combination of equations (1) and (2) result in

$$\left( \frac{\xi \mu}{\kappa} \right) \frac{\partial \rho}{\partial t} = (\nabla \cdot \rho (\nabla p - \rho g \cos \varphi)) \quad (3)$$

with the boundary conditions

Author  $\alpha$ : Department of Physics, University of Port Harcourt, Choba, Port Harcourt, Nigeria. e-mail: kellydap08@gmail.com

Author  $\sigma$ : Ignatius Ajuru University of Education, Rumuolumeni, Port Harcourt.



$$\rho(0) = 0 \text{ and } \rho(-1) = 1 \tag{4}$$

We write the equation of state for this study following the argument of [11] as

$$\rho = \rho_0 p^m e^{\beta p} \tag{5}$$

where  $\rho_0$  is the fluid density at unit pressure,  $m$  and  $\beta$  are integers.

### III. METHOD OF SOLUTION

For Isothermal expansion of fluids,  $m = 1$ ,  $\beta = 0$  and equations (3) and (5) reduced to

$$\frac{2\xi\mu\rho_0}{\kappa} \frac{\partial \rho}{\partial t} = \nabla^2 \rho^2 - \nabla \rho^2 g \rho_0 \cos \varphi \tag{6}$$

We approximate  $\rho^2$  by discarding powers of  $\rho$  greater than unity using Taylor's series expansion about 0 and rewriting equation (6) in one dimension, we get

$$\frac{\xi\mu\rho_0}{\kappa} \frac{\partial \rho}{\partial t} = \frac{\partial^2 \rho}{\partial x^2} - \frac{\partial \rho}{\partial x} \rho g \rho_0 \cos \varphi \tag{7}$$

To seek for solution of equation (7), we assume a solution of the form

$$\rho(x, t) = \theta(x) e^{-\lambda t} \tag{8}$$

where  $\lambda$  is a constant and the boundary conditions also transformed into

$$\theta(0) = 0 \text{ and } \theta(-1) = e^{\lambda t} \tag{9}$$

Substitution of equation (8) into equation (7) and simplify we obtain

$$\theta''(x) - \varpi \theta'(x) + \lambda f \theta(x) = 0 \tag{10}$$

$$f = \frac{\xi\mu\rho_0}{\kappa} \text{ and } \varpi = g\rho_0 \cos \varphi$$

The solution of equation (10) and the imposition of the boundary conditions of equation (9) as well as applying the transformation of equation (8), we get

$$\rho(x, t) = \frac{1}{1 - \exp\left(\frac{\varpi - \sqrt{\varpi^2 - 4f\lambda}}{2}\right)} \exp\left(\frac{\varpi + \sqrt{\varpi^2 - 4f\lambda}}{2}\right) x + \frac{1}{\exp\left(\frac{\varpi - \sqrt{\varpi^2 - 4f\lambda}}{2}\right) - 1} \exp\left(\frac{\varpi - \sqrt{\varpi^2 - 4f\lambda}}{2}\right) x \tag{11}$$

Using the equation of state as described in equation (5) and considering the case of isothermal expansion of fluids, we write equation (11) as

$$p(x) = \frac{1}{\rho_0} \frac{1}{1 - \exp\left(\frac{\varpi - \sqrt{\varpi^2 - 4f\lambda}}{2}\right)} \exp\left(\frac{\varpi + \sqrt{\varpi^2 - 4f\lambda}}{2}\right) x + \frac{1}{\rho_0} \frac{1}{\exp\left(\frac{\varpi - \sqrt{\varpi^2 - 4f\lambda}}{2}\right) - 1} \exp\left(\frac{\varpi - \sqrt{\varpi^2 - 4f\lambda}}{2}\right) x \tag{12}$$

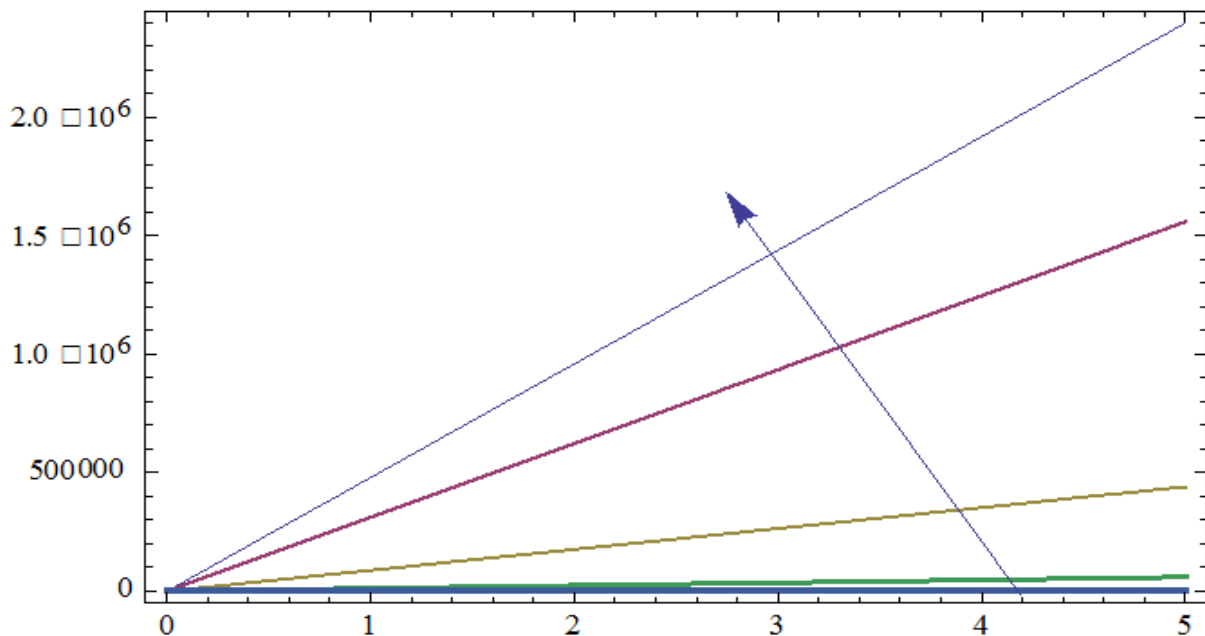

Figure 1: Pressure profile  $p$  against boundary layer  $x$  for varying angle ( $\varphi$ )

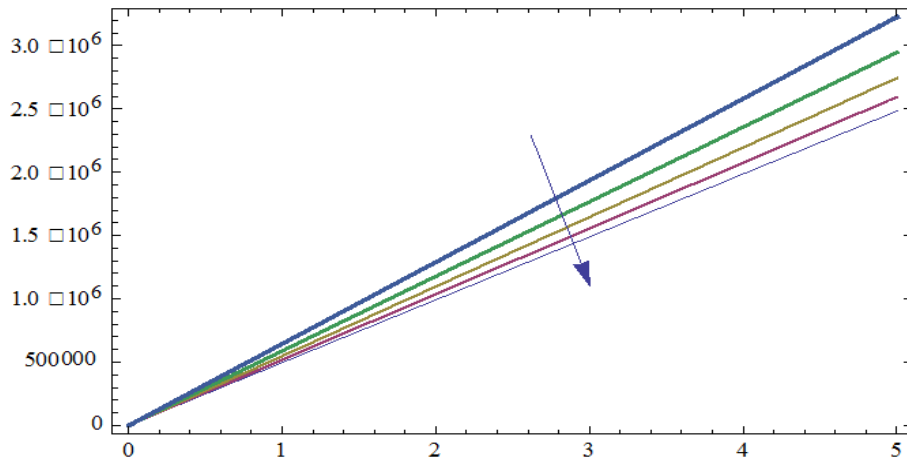

Figure 2: Pressure profile  $p$  against boundary layer  $x$  for varying porosity term  $\xi$

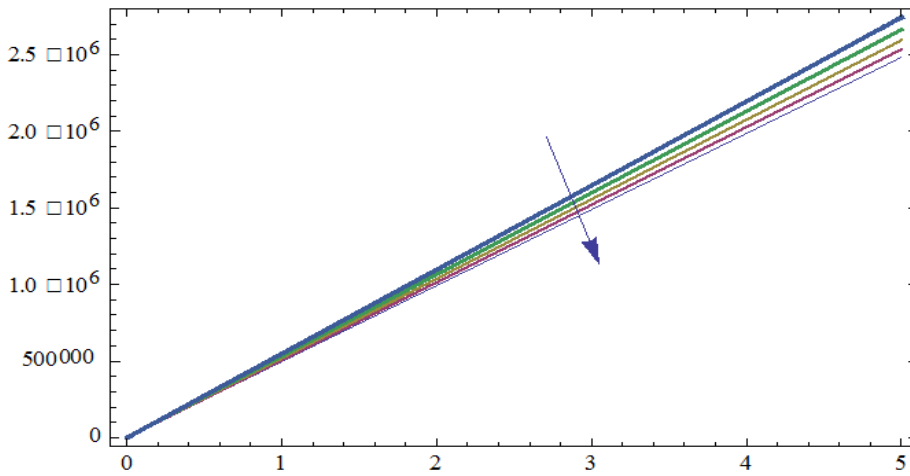

Figure 3: Pressure profile  $p$  against boundary layer  $x$  for varying viscous term  $(\mu)$

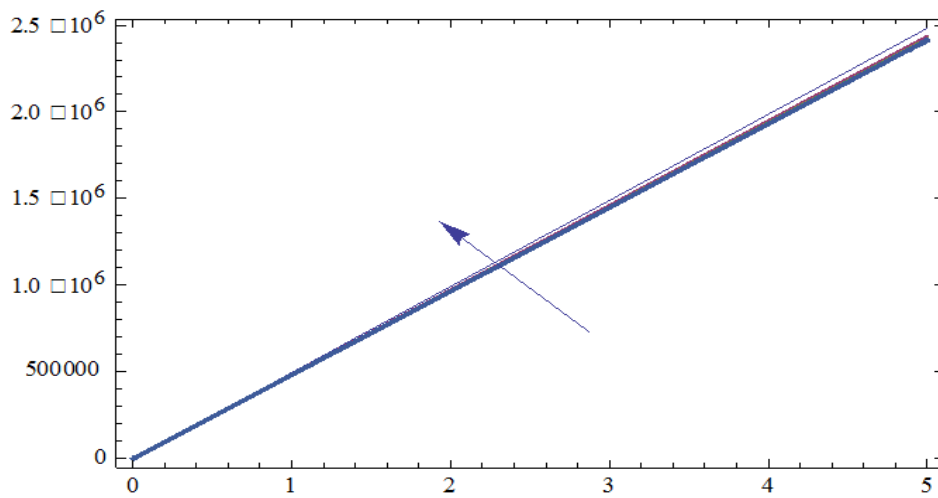

Figure 4: Pressure profile  $p$  against boundary layer  $x$  for varying permeability term  $(\kappa)$

For adiabatic expansion of fluids,  $\beta = 0$ , and  $C_p$  at constant pressure) and combination of equations (3) and (5) reduced to

$$m = \frac{C_v}{C_p} \quad (C_v \text{ is specific heat capacity at constant volume})$$

$$\frac{(m+1)\xi\mu\rho_0^{\frac{1}{m}}}{\kappa} \frac{\partial \rho}{\partial t} = \nabla^2 \rho^{\left(\frac{1+m}{m}\right)} - \nabla \rho^{\left(\frac{m+1}{m}\right)} g \rho_0^{\left(\frac{1}{m}\right)} \text{Cos } \varphi \quad (13)$$

Following the same procedure adopted for the isothermal case, we write equation (13) as

$$\frac{(m+1)\xi\mu\rho_0^{\frac{1}{m}}}{\kappa} \frac{\partial \rho}{\partial t} = \frac{(1+m)}{m} \frac{\partial^2 \rho}{\partial x^2} - \frac{m+1}{m} \frac{\partial \rho}{\partial x} g \rho_0^{\frac{1}{m}} \text{Cos } \varphi \quad (14)$$

Applying the solution technique of equation (8), transform equation (14) into

$$\theta''(x) - \frac{\beta_3}{\beta_2} \theta'(x) + \frac{\beta_1}{\beta_2} \lambda \theta(x) = 0 \quad (15)$$

where  $\beta_1 = \frac{(m+1)\xi\mu\rho_0^{\frac{1}{m}}}{\kappa}$ ,  $\beta_2 = \frac{m+1}{m}$ ,  $\beta_3 = \frac{m+1}{m} g \rho_0^{\frac{1}{m}} \text{Cos } \varphi$

The solution of equation (15) and the imposition of the boundary conditions of equation (9) as well as applying the transformation of equation (8), we get

$$\rho(x,t) = \frac{1}{\exp\left[\frac{\frac{\beta_3}{\beta_2} + \sqrt{\left(\frac{\beta_3}{\beta_2}\right)^2 - 4\frac{\beta_1}{\beta_2}\lambda}}{2}\right] - 1} \exp\left[\frac{\frac{\beta_3}{\beta_2} + \sqrt{\left(\frac{\beta_3}{\beta_2}\right)^2 - 4\frac{\beta_1}{\beta_2}\lambda}}{2}x\right] + \frac{1}{1 - \exp\left[\frac{\frac{\beta_3}{\beta_2} + \sqrt{\left(\frac{\beta_3}{\beta_2}\right)^2 - 4\frac{\beta_1}{\beta_2}\lambda}}{2}\right]} \exp\left[\frac{\frac{\beta_3}{\beta_2} - \sqrt{\left(\frac{\beta_3}{\beta_2}\right)^2 - 4\frac{\beta_1}{\beta_2}\lambda}}{2}x\right] \quad (16)$$

Using the equation of state as described in equation (5) and considering the case of adiabatic expansion of fluids, we write equation (16) as

$$\log p = \frac{1}{m} \log \left[ \frac{1}{\rho_0} \rho(x,t) \right] \quad (17)$$

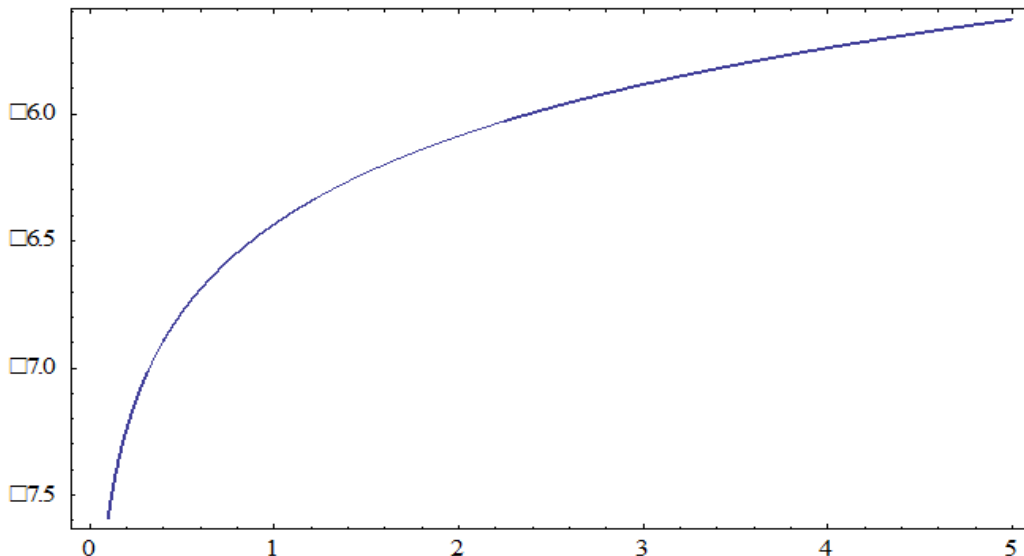

Figure 5: Pressure profile  $p$  against boundary layer  $x$  for varying angle ( $\varphi$ )

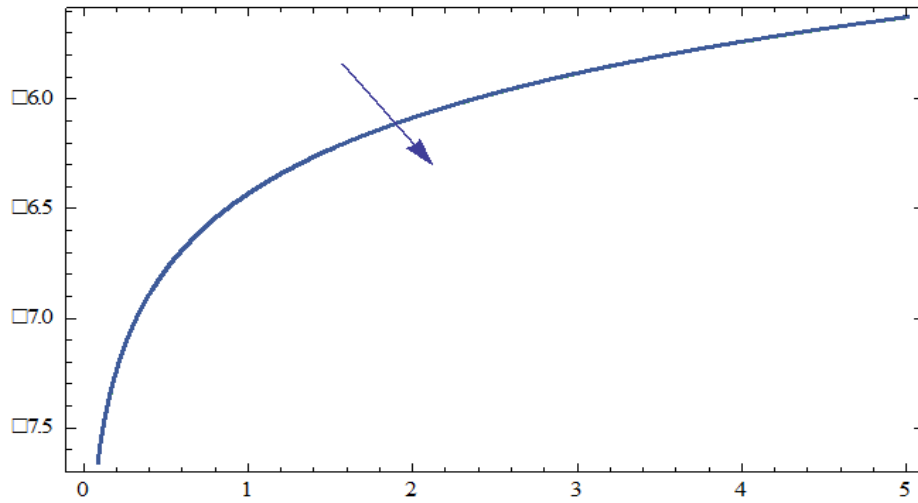

Figure 6: Pressure profile  $p$  against boundary layer  $x$  for varying porosity term.  $\xi$

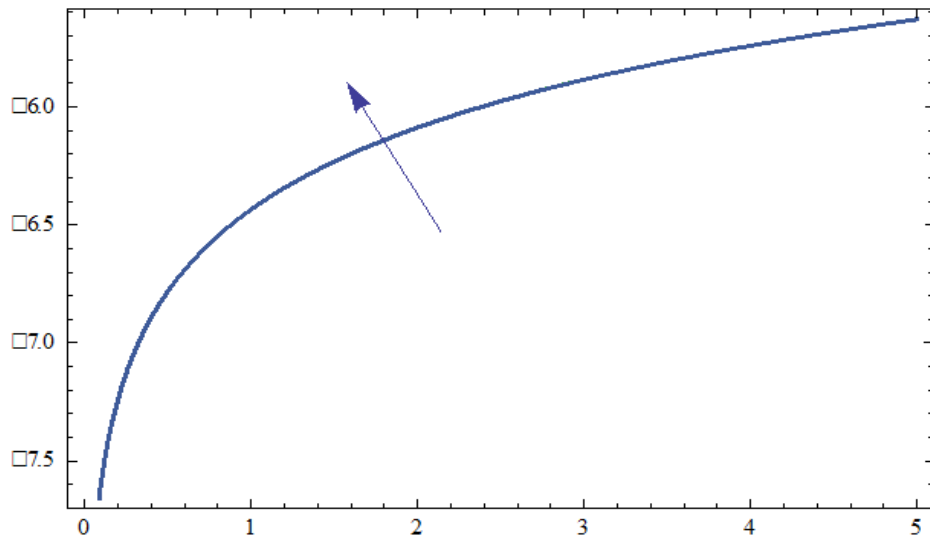

Figure 7: Pressure profile  $p$  against boundary layer  $x$  for varying permeability term ( $\kappa$ )

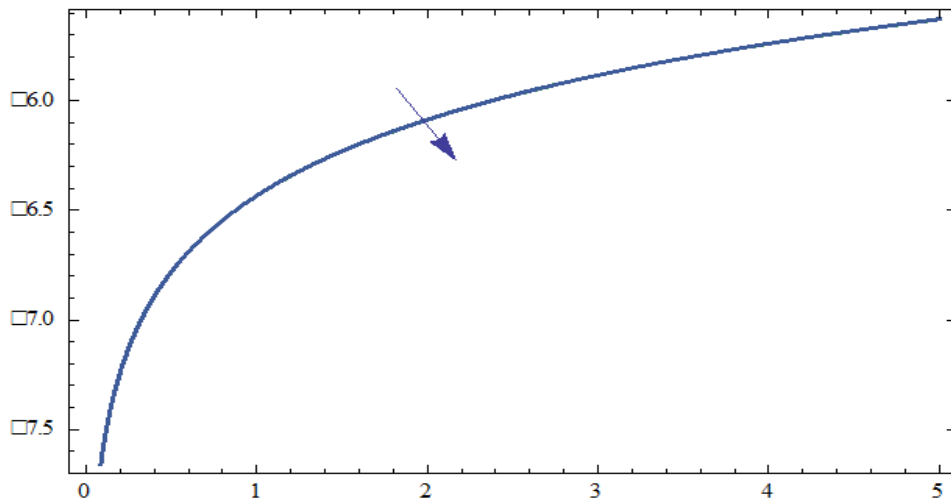

Figure 8: Pressure profile  $p$  against boundary layer  $x$  for varying viscous term ( $\mu$ )

## IV. RESULTS AND DISCUSSION

For numerical validation and physical insight of the problem, an approximate value of the ratio of specific heat capacity at constant volume to that at constant pressure  $\left(\frac{C_v}{C_p} = 2\right)$ , constant viscosity of fluid

at  $20^{\circ}C$  (air  $\mu = 1.0 N.sm^{-2}$ ) and constant ( $\lambda = 0.0035$ ) is chosen. The values of other parameters made use of are

$$\xi = 0.6, 1.2, 1.8, 2.4, 3.0$$

$$\kappa = 0.5, 1.0, 1.5, 2.0, 2.5$$

$$\rho_0 = 1.29 kgm^{-3}$$

$$\mu = 1.0, 1.5, 2.0, 2.5, 3.0$$

$$\varphi = 0, \frac{\pi}{12}, \frac{\pi}{6}, \frac{\pi}{4}, \frac{\pi}{3}$$

Analysis of figure 1 shows that increase in the tilting of the granules result in an increase in the pressure exerted on the photosphere in the isothermal fluid case but from figure 5 in the adiabatic fluid case, increase in the angle of the granules does not affect the pressure on the granules. Figure 2 depicts the behaviour of increase in porosity on the pressure of the fluid, it is shown that increase in porosity leads to a corresponding decrease on the pressure of the fluid thereby reducing the granules. The same behaviour is observed in the adiabatic fluid case as illustrated in figure 6. Figure 3 shows that increase in viscosity results in decreasing the pressure of the photosphere thereby reducing the pressure of the permeability of the fluid. The same physical situation occurs in the adiabatic fluid case as it is observed in figure 8. Increase in permeability, result in an increase in the pressure of the fluid as shown in figure 4, for the isothermal case and same situation is observed in the adiabatic fluid case as depicted in figure 7. The physical observation of porosity and permeability are in agreement with the work of [4].

## V. CONCLUSION

For gases, it is customary to neglect the gravity (g) term, since it is small compared with the pressure terms as in the case of non gravitating gas but our study is for gravitating gas as in astrophysics and hence the gravity term is not neglected. In addition studying the physics of tilting the granules is new which we have analyzed.

## REFERENCES RÉFÉRENCES REFERENCIAS

1. Randolph H. L and Kenneth R. L 2009. The Photosphere. Microsoft® Encarta®
2. Bestman, A R 1985. AMSE Press. 5(1): 19-22.
3. Ngiangia, A. T; Amadi, O and orukari M. A. 2011. Cont. Jour. of renewable energy. 2(1): 19-25.

4. Ngiangia, A. T and orukari M. A. 2015. Jour. of Advances in Phys. 11(1): 2892-2896.
5. Alabi, O. O and Olayiwola, M. O 2015. Jour. of NAMP. 31: 223-230.
6. Cunningham, R. E. and Williams, R. J. J. 1980. Diffusion in Gases and Porous Media, Plenum Press, New York.
7. Carrigy, N.; Pant, L. M.; Mitra, S. K.; Secanell, M. 2013. Jour. of the Electrochemical Society 160: F81-F89.
8. Pant, L. M.; Mitra, S. K.; Secanell, M. 2012. Journal of Power Sources 206: 153-160.
9. Klinkenberg, L. J. 1941. American Petroleum Institute. 200-213.
10. Jin, Y.; Uth, M.-F.; Kuznetsov, A. V.; Herwig, H. 2015. Jour. of Fluid Mech. 766: 76-103.
11. R. B Bird, W. E Stewart and E. N Lightfoot. 2002 Transport Phenomena (John Wiley and Sons Inc.) second edition. Ch 4, P 148
12. Alabi, O. O and Sedara, S. O 2015. Int. Jour. of Computers and Tech. 11(3): 3121-3127.



# Tokamak, Accelerators, Colliders and Maxwell's Electrodynamics

By Stanislav Konstantinov

*Russian State Pedagogical University*

**Abstract-** The article raises the question of revision of Maxwell's electrodynamics and the refusal from of the Lorentz calibration. Relatively modest results of years of work of the collective of the National Research Centre "Kurchatov Institute" in the creation of a fusion reactor based on the tokamak due to the fact that Maxwell's electrodynamics is very different from the real electrodynamics in a tokamak. The tunnel effect points the way for a truly controlled nuclear fusion. The article says that the relativistic equations for calculating the energy of the accelerator cannot be used and physicists have to ask the question: "What is the true energy of the charged particles in the accelerator?".

**Keywords:** tokamak (toroidal chamber with magnetic coils for plasma confinement), a toroidal (non-force) magnetic field, poloidal (force) magnetic field, vector potential  $a$ .

**GJSFR-A Classification:** FOR Code: 029999



*Strictly as per the compliance and regulations of :*



# Tokamak, Accelerators, Colliders and Maxwell's Electrodynamics

Stanislav Konstantinov

**Abstract-** The article raises the question of revision of Maxwell's electrodynamics and the refusal from of the Lorentz calibration. Relatively modest results of years of work of the collective of the National Research Centre "Kurchatov Institute" in the creation of a fusion reactor based on the tokamak due to the fact that Maxwell's electrodynamics is very different from the real electrodynamics in a tokamak. The tunnel effect points the way for a truly controlled nuclear fusion. The article says that the relativistic equations for calculating the energy of the accelerator cannot be used and physicists have to ask the question: "What is the true energy of the charged particles in the accelerator?".

**Keywords:** tokamak (toroidal chamber with magnetic coils for plasma confinement), a toroidal (non-force) magnetic field, poloidal (force) magnetic field, vector potential  $a$ .

## I. INTRODUCTION

2016 marks 10 years (2006) the beginning of the project between Russia, EU, USA, Japan, China, Korea and India for the joint construction of the International Thermonuclear Experimental Reactor (ITER) in France based on the tokamak. Prospects for the tokamak as a thermonuclear (14 MeV) neutron source are examined. In June 2016 it was reported to delay completion of the work from 2020 to 2025. Today, we can talk about a complex problem faced by the creators of the ITER project, because for the calculation of electrodynamics in a tokamak currently used classical equations of Maxwell. Real electrodynamics inside the

tokamak is very different from the calculation [1]. Hot plasma particles move along magnetic field lines of arbitrary topology to the walls of the tokamak and destroy it. Here is a brief history of tokamak. In June 1950 soldiers Oleg Lavrent'ev wrote in a letter to the Academy of Sciences of the USSR, which proposed to create a system with electrostatic confinement of hot plasmas for controlled thermonuclear fusion (CTF). CTF is a synthesis of heavier atomic nuclei of lighter atomic nuclei with the release of large amounts of energy. At a temperature of 100 million degrees initial nucleons or light hydrogen nucleus can overcome the electrical repulsion force and the distance of the nuclear forces of gravity to form heavier nuclei of helium atoms. Natural fusion reactor, the sun, which is already billions of years are uncontrollable processes of nuclear fusion of helium nuclei of hydrogen deuterium. In terrestrial conditions, an inexhaustible source of hydrogen for thermonuclear power can become water. Initiative O.Lavrent'ev to create a magnetic trap for the hot plasma Support was academics Andrei Sakharov and Igor Tamm. In october 1950, they offered a toroidal device with longitudinal magnetic field to keep the hot plasma, now known as the tokamak. The world's first toroidal unit with a strong longitudinal magnetic field TMF (torr with the magnetic field) was built in 1955 in the USSR. In 2015 modernized the tokamak T-15, plasma confinement duration in which less than 1s, while both the draft T-15 retention time in a steady state plasma should be 5-10 seconds



Oleg A. Lavrent'ev  
(07.07.1926 – 10.02.2011)

Andrei D. Sakharov  
(21.05.1921 – 14.12.1989)

Igor E. Tamm  
(08.07. 1895 – 02.04. 1971)

Figure 1: The initiators of the research into controlled thermonuclear fusion based on the tokamak.

**Author:** Department of Physical Electronics, Russian State Pedagogical University, St.Petersburg, RCC "Energy", Russia.  
e-mail: konstantinov.s.i@yandex.com

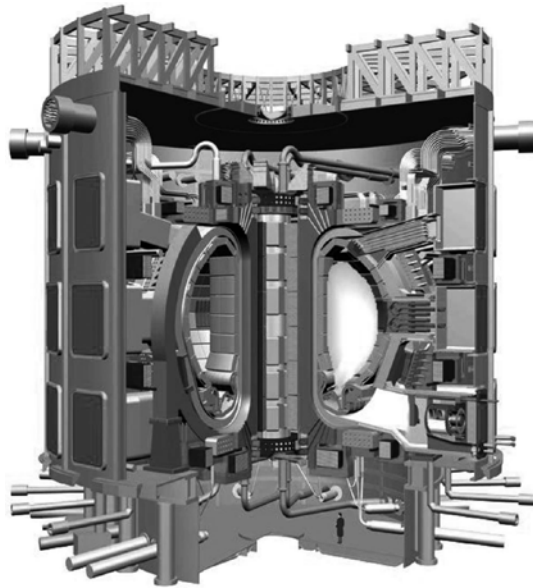

Poloidal section of ITER reactor  
To estimate the size of ITER in the lower part of the figure shows the silhouette of a man.

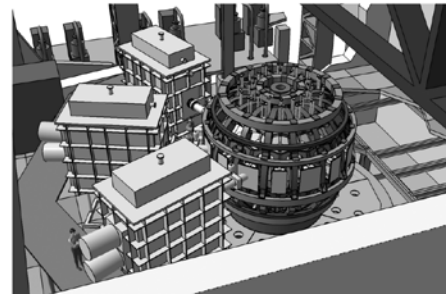
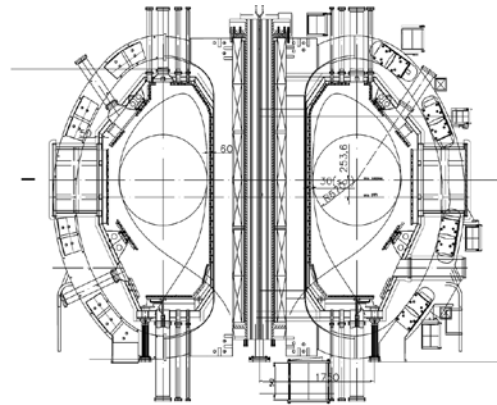

The cross section of the Tokamak T-15 (a)  
placing the T-15 tokamak in the experimental room (b)

Figure 2

## II. REAL ELECTRODYNAMICS INSIDE THE TOKAMAK

Tokamak is a toroidal chamber with magnetic coils, designed for magnetic plasma confinement in order to achieve the conditions necessary for the occurrence of controlled thermonuclear fusion. To create the magnetic trap uses a combination of magnetic fields: strong toroidal field  $B_t$  and a weaker (100 times) poloidal field  $B_p$ , as well as the  $B_i$  field current  $I$ , flowing through the plasma column. It is believed that the plasma is stable in a tokamak if the criterion Shafranov - Kruskal:

$$B_t / B_i > R / \alpha \quad (1)$$

where  $R$  - radius of the circumference of the plasma ring,  $\alpha$  - the radius of the cross section of the plasma column.

However, due to the effect of self-generation strong toroidal magnetic field  $H_t$  poloidal magnetic field  $H_p$ , and vice versa, hold the plasma in a tokamak a long time is not possible. The more intense toroidal magnetic field generated by the windings of the toroid, and it reaches 3-5Tl in the tokamak, the more intense extra poloidal magnetic field will be created by it. Chief Scientific Officer of the Siberian Branch of the Russian Academy of Sciences, professor V. V. Aksenov experimentally and mathematically substantiated the

effect of self-excitation and the uncontrolled growth of magnetic fields. This leads to uncontrolled instabilities of plasma column [1, 2]. Self-excitation process will grow almost instantly due to the mutual generation of the above-mentioned magnetic fields. When the temperature rises inside the tokamak diffusion rate will also increase due to the growth of the resistance (conductivity drop) the plasma column and growth of the poloidal field inside the tokamak. Today in EAST tokamak Chinese Institute of Plasma Physics succeeded in a record time of plasma confinement during the 30s, and in the ITER project is necessary to achieve the following: at steady state  $P_{fus} = 0,4-0,5$  GWt and  $Q > 5$  and to bring the length of the plasma confinement before 3000s. In the natural fusion reactor, such as the Sun, regularly observed coronary solar plasma emissions, which indicates the instability of a solar reactor. Such plasma emissions from a fusion reactor could lead to an environmental disaster.



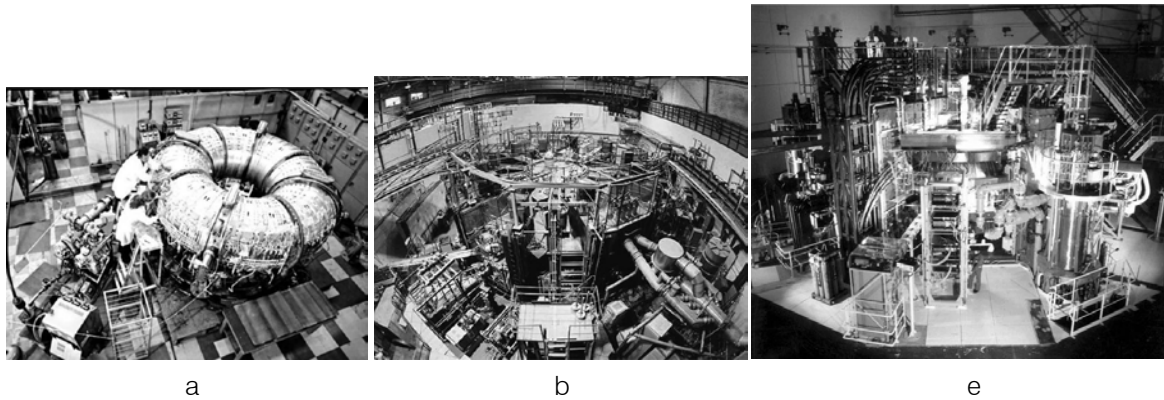

Figure 3: Tokamaks with superconducting coils: (a) the assembly of the superconducting coils of the tokamak T-7, (b) T-15, (e) ITER.

### III. PARADOXES IN ELECTRODYNAMICS THEORY

In the early 20th century it became clear that Maxwell's electrodynamics requires revision and improvement. But it took more than 100 years, and this task is not finished today. Attempts by a number of scientists [1,3,7,8,9] to point out the obvious contradictions and paradoxes of the classical and quantum electrodynamics encounter complete misunderstanding and fierce opposition from the apologists of the ruling today in the physics of Einstein's SRT and GRT. As a result the Maxwell equations have been separated from the original model of the environment in which the conduction currents and displacement played a very definite physical role. Since then, the electrodynamics of Maxwell lost virtually every opportunity its additions, changes and improvements. Currently in electrodynamics accumulated a lot of contradictions and paradoxes, which, in the framework of modern theoretical concepts do not have an explanation. Here are some of them:

- 1) The paradoxical role of the bias currents in the induction of the magnetic field of the moving charge. In the modern sense of electrodynamics is dominated by the belief that only the magnetic field generated by currents transfer  $\mathbf{j}(\mathbf{r}) \neq 0$

$$\text{rotH} = 4\pi / c \mathbf{j}t, \tag{2}$$

$$\text{divH} = 0$$

What is bias currents? Maxwell called component  $\mathbf{j}_b = 1/4\pi (d\mathbf{E} / dt)$  in their equations "bias current", meaning that the electric field is created in the luminiferous ether due to the relative motion of its constituent oppositely charged particles that form the dipole. On the one hand the bias currents are a physical reality, because without them it is impossible to understand the workings of a simple capacitor, on the other displacement currents - a mathematical formality, with which it is possible to make the symmetrical Maxwell equations. On one side of the magnetic properties of bias currents are taken to be equivalent

magnetic currents transfer properties, on the other hand charges moving magnetic fields are determined for some reason, only the transfer currents as the bias currents are thus missing.

- 2) Erroneous application of Gauss's theorem not only for resting the charge, but also for moving. As a result the dynamic state of the moving electric charges simply replaced by their static state. However, experimentally established parallel interaction of moving charges  $e_1$  and  $e_2$  with  $v_1 = v_2 = v$  and  $\mathbf{v}(\mathbf{r}) = 0$ , and the force of interaction between the charges in their motion changes. Coulomb's law (Gauss theorem - one of Maxwell's equations) is valid only for fixed charges. As part of the well-known concepts in electrodynamics, the magnetic interaction between the two at all ruled out moving in a straight line charges. Although experimentally obtained an interesting relationship to the magnetic fields interacting charges moving in a straight line. Experiments confirmed the existence of longitudinal forces between charges moving in a straight line [3];

- 3) It is ironic, but the differential equations of Maxwell are not able to correctly describe the phenomenon of electromagnetic induction in a conventional transformer, because the vortex field  $\mathbf{E}(\mathbf{r})$  induction in the space around the transformer is induced regardless of the presence in the same space magnetic fields variable in time  $\mathbf{H}(\mathbf{r})$ , that is, when provided  $d\mathbf{H} / dt = 0$ . In other words, for any point  $\mathbf{r}$  of space around the transformer for differential Maxwell's equations, the induction eddy electric field  $\mathbf{E}$  must be absent. However, the reality of the existence of magnetic fields in electrically sensitive environments ( $\epsilon_0, \mu_0$ ) for any point in space near the coil primary circuit magnetization is easy to install by placing this space winding magnetizing the second closed circuit. As a result of the magnetic interaction with the primary field in the secondary circuit generates energy, which can be registered. This effect can be used to create a generator with an efficiency of  $> 100\%$ , working

against all the laws of both classical Maxwell electrodynamics and quantum electrodynamics. More "gratuitous" energy in the generator can be explained by disturbances in the environment between the ferromagnetic cores with windings separated by a relatively small gap of a dielectric material (2-3 mm.). Ferrite cores are placed in the field, enhance the electromagnetic characteristics of the medium ( $\epsilon$ ,  $\mu$ ). Replacing the ferrite cores on electrical steel cores can enhance the effect in the secondary circuit in the dozens of times, as in the ferrite electromagnetic induction reaches a maximum of 0.4 - 0.5 TI, and in the electrical steel magnetic flux density is 1.5 -2 TI and more.

- 4) The formalism of the field vector potential  $\vec{A}$  is well-used to describe the phenomenon of electromagnetic induction current in the conductor of the transformer outside, because outside of the transformer, provided  $dH / dt = 0$  is realized  $dA / dt \neq 0$  condition. Researcher of the Tomsk Polytechnic University G.V. Nikolaev, using the single-valued magnitude of physical property of vector potential  $\vec{A}$  and moving charge  $e$ , at ( $v \ll c$ ) [3]

$$\vec{A} = ev/cr, \tag{3}$$

ascertained existence of two types of magnetic fields in the space around it:

$$\text{vector field } \mathbf{Ht} = \mathbf{H}^\perp = \text{rot}\vec{A} \tag{4}$$

$$\text{scalar field } \mathbf{Hp} = \mathbf{H}^\parallel = -\text{div}\vec{A} \tag{5}$$

- 5) Paradoxically, in classical electrodynamics particle can move with a constant acceleration, generating energy from nowhere. It is known that in the case of charged particle movement in plane condenser with the constant tension to be applied classical uniformly accelerated motion  $x = at^2$  appears. If during acceleration of a charge one takes into account force acting on a charge itself, then the braking due to radiation arises. In different works this effect is called in different way: Lorenz frictional force or Plank's radiant friction. That force is proportional to third derivative of coordinate  $x$  relative to time and was experimentally proved many years ago. If we write the equations of motion for the charge moving in space free from external fields impact and if the only force acting on the charge is the "Plank radiant friction", then we would obtain following equation:

$$m \frac{d^2x}{dt^2} = \frac{2e^2}{3c^3} \frac{d^3x}{dt^3} \tag{6}$$

It is evident that equation in addition to trivial particular solution  $v=dx/dt=Const$  has general solution where particle acceleration is equal:

$$\alpha = \frac{d^2x}{dt^2} = C \exp\left[\frac{3mc^3t}{2e^2}\right] \tag{7}$$

i.e. is not only unequal to zero, but more over it unrestrictedly exponentially increases in time for no reason whatever!!! L.Landau and E.Lifshits in their classical work "Theory of the field" wrote apropos of this: "A question may arise how electrodynamics satisfying energy conservation law is able to give rise to such an absurd result in accordance to which a particle was able to unrestrictedly increase its energy. The background of that trouble is, actually, in infinite electromagnetic "eigen mass" of elementary particles."

In the Unitary Quantum Theory professor L.Sapogin proposed the same solution for the equation with the oscillating charge [9]. Let show that Schroedinger equation has physically similar solution also. Viz., let potential in Schroedinger equation be equal  $U(x) = rx$ . Then complete Schroedinger equation is as follows:

$$\frac{\hbar^2}{2m} \frac{d^2\Psi(x,t)}{dx^2} - rx\Psi(x,t) + i\hbar \frac{d\Psi(x,t)}{dt} = 0 \tag{8}$$

We will seek the solution in rather unusual form

$$\Psi(x,t) = b \exp\left(i \frac{m\alpha^2 t^3}{2\hbar} - i \frac{m\alpha t x}{\hbar}\right) \tag{9}$$

Bu substituting (9) in (8) we get (after reducing):

$$-2m\alpha^2 t^2 + (m\alpha - r)x = 0 \tag{10}$$

This relation will be fulfilled if

$$x = \frac{2m\alpha^2}{m\alpha - r} t^2 \tag{11}$$

If in (11) impose the requirement  $r \rightarrow 0$  (potential vanishes), then absolutely strange particular solution appears where the particle is able to move with constant acceleration and to generate energy no of an unknowns where origin. That effect remains valid even if we put  $r \rightarrow 0$  directly in equation (8);

- 6) Maxwell himself pointed out the difficulties with his equations to non-closed electric currents and the individual elements of the current. These difficulties lie in the fact that for the open currents alone, non-zero spatial derivative  $\text{rot}\vec{A} = \mathbf{H}$  vector potential  $\vec{A}$  cannot determine it completely. It revealed the existence of yet another non-zero spatial derivative  $\text{div}\vec{A} \neq 0$  of the vector potential  $\vec{A}$ . In general, the vector potential  $\vec{A}$  can be represented as the sum of the potential and vortex components of  $\vec{A}t + \vec{A}p$ . This current element creates: the vector magnetic field

$$\mathbf{Ht} = \text{rot } \vec{A}t, \tag{12}$$

and the scalar magnetic field

$$\mathbf{Hp} = -\text{div } \vec{A}p \tag{13}$$

It turns out that an infinitely long current conductor generates a magnetic field  $\mathbf{Ht}$ , but the current conductor of limited length creates a magnetic field

vector  $H_t$  and the scalar magnetic field  $H_p$ . Since isolated current element is hard to imagine, since this requires the source and drain of charges, the field configuration is of interest in case of a real closed currents, in particular for this purpose may be a toroid [7].

7) Analyzing the causes of conflict in the modern electrodynamics can note a recognized violation of the third law of Newtonian mechanics allowed by both quantum and classical electrodynamics. This is reflected in the recognition of some of the transverse Lorentz force, with complete disregard for the existence equal to them in size and identical nature of the longitudinal magnetic forces of reaction. From the fact of gross violation of the third law of mechanics in the magnetic interaction of perpendicular elements AC, it follows that, by reason of the principle of superposition, the same gross violation III of mechanics should be expected in the magnetic interaction again perpendicular, but macroscopic current segments that make up the real circuit tokamak .

#### IV. CORRECTION OF MAXWELL'S EQUATIONS OF ELECTRODYNAMICS

Correction of Maxwell's equations of electrodynamics based on the recognition of an additional magnetic field, which creates a force in addition to the transverse Lorentz forces acting along the direction of the current. The expression for the electromagnetic energy flux density (Poynting vector) has the form

$$\mathbf{S} = (\mathbf{E} \times \mathbf{H}_r) + (\mathbf{E} \times \mathbf{H}_p) \quad (14)$$

Changing the scalar magnetic field equivalent to the formation of electrical charges, which change in turn generates an electric potential field. The longitudinal wave propagates along the axis toroyda in the tokamak plasma column. Based on experimental results, it is proposed to abandon the Lorentz calibration, but instead take the expression for the electromagnetic energy density in the form [6]:

$$\mathbf{S} = -\text{div } \bar{\mathbf{A}} - \lambda \epsilon_0 \mu_0 \text{d}\phi/\text{d}t \quad (15)$$

Obviously, potentials imposed thus allow great flexibility in the use of Maxwell's equations. In the classical case relies  $S = 0$ . When using the calibration (15) at  $\lambda = 0$  we obtain the Coulomb gauge, and at  $\lambda = 1$  we have the Lorentz gauge. If you do not assume the vanishing of the expression for S, then at  $\lambda = 0$  the scalar field acquires the meaning of a longitudinal magnetic field. Further transformations are performed in the standard way, with the result that allows to obtain the following system of equations:

$$\text{d}\mathbf{E}/\text{d}t - \text{rot}\mathbf{H} - \text{grad } \mathbf{S} = 0,$$

$$\text{d}\mathbf{H}/\text{d}t + \text{rot}\mathbf{E} = 0, \quad (16)$$

$$\text{div } \mathbf{E} - \text{d}\mathbf{S}/\text{d}t = 0,$$

$$\text{div } \mathbf{H} = 0$$

For ease of reference the equations (16) Consider the case of absence of currents and charges and accepted  $\epsilon_0 = \mu_0 = 1$ .

For clear separation of the concept of a longitudinal wave in a vacuum, and the longitudinal electromagnetic waves that exist in material media, in [7] proposed to call the longitudinal electromagnetic E-wave of a wave, in which the magnetic field is zero, and the vector of the electric field is directed along the propagation direction fluence. This is a scalar function  $\mathbf{SE} // = \alpha \mathbf{E}$ , where  $\alpha = \alpha(x, y, z, t)$ . Similarly, H is determined by the longitudinal wave generating energy flow  $\mathbf{SH} // = b\mathbf{H}$ .

Differential equations for the generalized electromagnetic field can be derived from the concept of the Poynting vector. Poynting vector for a general electromagnetic waves, including both conventional fashion transverse and longitudinally polarized modes can be represented as:

$$\mathbf{S} = \mathbf{E} \times \mathbf{H} + \alpha \mathbf{E} + b\mathbf{H} \quad (17)$$

The corresponding energy density of this vector is expressed as:

$$W = 1/2 (E^2 + H^2) + WE// + WH// \quad (18),$$

where  $WE //$  and  $WH //$  - extra energy.

A rigorous derivation of the additional energy and differential equations for generalized electromagnetic field are given in [7].

Professor V. Aksenov in article [1] offers another modification of Maxwell's equations with non-power electromagnetic fields for the toroidal electrical currents, without taking into displacement currents. The modified equation Aksenov shed light on the skin effect problem in the non-power magnetic fields [1].

#### V. EXPERIMENTS

a) *Experiment of the Aharonov-Bohm*

It is generally accepted that if the magnetic field H is known, there is no need to refer to "formal" vector potential  $\bar{\mathbf{A}}$ . However, the mere fact that the Schrödinger wave equation appears only vector potential was obvious since the inception of this equation. Unsuccessful attempts to replace the vector potential  $\bar{\mathbf{A}}$  in the equations of quantum mechanics "physical" magnetic field H is said that the wave function of any moving charge in the field of the vector potential  $\bar{\mathbf{A}}$ , should reflect the existence of a quite tangible interaction between a moving charge with this field. This interaction can be characterized by the magnitude of potential  $\bar{\mathbf{A}}$  change and the wave function. In 1956. in quantum physics has been demonstrated simple

experiment, the result of which is known as the Aharonov -Boma [4]. When an electron moves along the long solenoid with a current, the electron trajectory is changing, although the magnetic field outside the solenoid is zero ( $B = 0$ ). Aharonov-Bohm effect has several explanations [1,3,4]. Feynman explains the effect of the interaction of the particles with the vector potential  $\vec{A}$  [4], while Nikolaev and V.Aksenov suggest that the particle interacts with the magnetic field. In electrostatics Nikolaev particle interacts with a new longitudinal scalar magnetic field  $H_{||}$  [3], in theory, toroidal and poloidal magnetic fields V.Aksenov particle interacts with the non-force toroidal magnetic field  $H_t$  [1]. In theory, Nikolaev scalar magnetic field generated by currents of displacement, in theory Aksenov non-force magnetic field is generated by the displacement currents occurring between the plates of the capacitor and conduction currents. The experimentally observed phenomenon of the power of moving electrons interact with the field of the vector potential  $\vec{A}$  in the experiments of the Aharonov-Bohm effect, was confirmed in later experiments by Japanese scientists (1984) [5]. During experiments, it was found change in the phase of the wave function of a moving charge in the absence and presence in the test area of the vector potential field  $\vec{A}$ , the complete absence in this area of the magnetic field  $H$ . The positive results of experiments matched only unique value of the vector potential  $\vec{A}$ , is compared with the same parameters unambiguous elemental power. Changing the phase of the wave function of the vector potential  $\vec{A}$  is given by:

$$\Delta\phi = q / \hbar \int \vec{A} ds, \tag{19}$$

where the integral is taken along the particle's trajectory. Experimental discovery of the phenomenon of longitudinal force effect of interaction along the axis of

current toroid of electrons with the field of vector potential  $\vec{A}$  in the experiments of Aharonov-Bohm make one revise the well-established view about the transverse magnetic Lorentz forces alone and accept the presence of longitudinal forces of magnetic interaction.

b) *The cathode-ray tube with a toroidal winding (A.Kostin's experiments)*

To demonstrate the phenomenon of moving charge interaction with the field vector potential  $A$  at the cathode-ray tube 1, at the location of the deflecting plates 2, 3. wearing toroidal coil toroidal winding made of outer and inner layers of wound copper wire of 0.62 mm with a total of 500 turns. the need for a two-layer winding caused by the fact, to prevent the magnetic field of the ring current (one left-winding spiral, the other - the right-helical). The windings are connected so that their magnetic fluxes summed. The electrons are accelerated in the tube potential difference 400V. On the vertical plate was fed a constant deflection voltage to set the on-screen (5-20 mm) of the electron beam of the base offset. The current in the coil was varied 0-5A. The experimental results are plotted. As the current increases in one direction of the electron beam deflection angle increases in magnitude relative to the reference deviation. Increasing the angle of deflection of the electron beam at a constant voltage across the deflection plates is due to a decrease in the electron beam velocity due to their interaction with the field of the vector potential  $A$  toroidal winding. When the current in the coil on the back, the electron beam deflection angle decreases its value in relation to its baseline deviation, registering the effect of increasing the speed of the electron beam in their interaction with the field of the vector potential  $A$  toroidal winding.

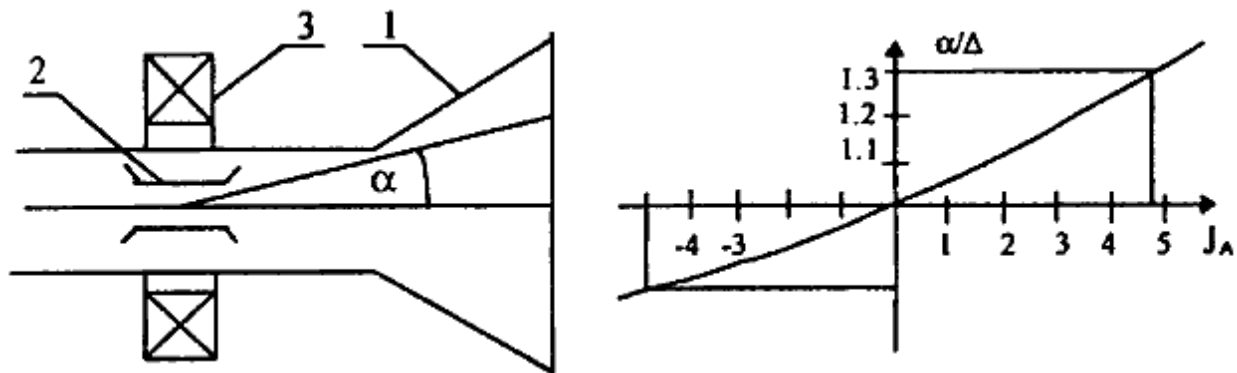

Figure 4: Cathode-ray tube with a toroidal winding

Thus, the results clearly prove the existence of a conventional classical analogue of the well-known experience of the Aharonov-Bohm and confirm the existence of a previously unknown phenomenon in the science of the longitudinal magnetic interaction [3]. Not paying attention to the new scalar magnetic field  $H_{||} = -$

$\text{div}\vec{A}$  and related new longitudinal magnetic interactions science cannot provide a sufficiently reliable theory of electrostatics of charged particle accelerators and collider. The phenomenon of longitudinal magnetic interaction present in the accelerator in the form effect of longitudinal instability of accelerated charged

particles, it is experimentally proven fact. An example of this can serve as a spurious "edge effects" longitudinal induction currents in the conductive medium in the MHD-generator.

## VI. CALCULATION OF ENERGY ACCELERATORS

The problem of the interaction of the space environment with electromagnetic energy of the moving charge, and replacement of the controversial idea of increasing the mass of the moving charge to infinity when approaching the speed of light, a more acceptable from a physical point of view of understanding of the deformation of the electric field of a moving charge and reduced to zero the force of interaction with him. The initial energy of the electric field of a stationary charge is reduced when driving this charge in the amount of energy detected magnetic field, ie the magnetic energy in the environment around a moving charge does not appear, as is commonly believed, and extracted from it. The initial energy of the electric field of a stationary charge  $W_{E_0}$  decreases when moving this charge an amount equal to the complete energy of the detected magnetic field  $Hc=(v/c)E$ . Interaction of electric charge  $e$  and the electric field  $\mathbf{E}_0$  is, given the retarded potentials and distortion of the electric field  $\mathbf{E}$  of the moving charge, It is described by the dependence [3]:

$$\mathbf{F} = \mathbf{E}_0 q\sqrt{1-v^2/c^2} \quad (20)$$

Taking into account the mass of the charge and acceleration  $\alpha$ , the dependence (20) can be written in the form:

$$\mathbf{F} = \mathbf{E}_0 q\sqrt{1-v^2/c^2} = m_v\alpha = \frac{m\alpha}{\sqrt{1-v^2/c^2}} \quad (21)$$

Within the framework of the relativistic concepts of modern electrodynamics dependence (21) is interpreted as the effect of "increasing the mass"  $m_0$  moving charge to infinity when approaching the speed of motion of the charge to the speed of light. However, equation (21) is a relativistic effect of reducing the force interaction of the moving charge with the electric field  $\mathbf{E}_0$ , formed by a stationary charge. The effects of delayed potentials and deformation of the electric field of moving charges leads to a restriction of the growth of the mass of the charge, at  $v \rightarrow c$ . The increase in particle mass at a rate occurs for other reasons (non-relativistic effect). Structural elements the dipoles (virtual electrons and positrons) of the ether ( $r$ ,  $dr$ ), including the charge  $e_0$  as well as electromagnetic parameters of the ether -  $\epsilon_0$ ,  $\mu_0$ , allow us to determine Planck's constant [11]:

$$h = 2\pi e_0 \frac{r}{dr} \sqrt{\frac{\mu_0}{\epsilon_0}} \quad (22)$$

where  $\mu_0$  - magnetic permeability;  
 $\epsilon_0$  - dielectric constant;

$r$  - the size of a structural element of the dipole of the ether  $r = 1.3988 \cdot 10^{-15}$  m;  
 $dr$  - the ultimate deformation of the dipole (destruction limit)  $dr = 1.0207 \cdot 10^{-17}$  m.

Planck's constant  $h = 6.6260 \cdot 10^{-34}$  (joule · s) completely depends on the characteristics of ether.

This implies that the de Broglie formula that sets a connection between the wavelength ( $\lambda$ ) of any particle and its momentum ( $mv$ )

$$\lambda = h / mv \quad (23)$$

where  $h$  is Planck's constant;

$m$  is a particle mass;

$v$  is a particle speed;

also depends on the features of the environment and the momentum of the particle. The momentum belongs to the particle, while transverse oscillations (electro elastic deformation of bound charges) appear in the environment when the particle moves with speed  $V$  - this is a trace of the particle in the environment. A screw type sinuous oscillatory motion of particles is so-called uncertainty of particles Heisenberg's trajectories. When the oscillation frequency of the electromagnetic field that occurs when a particle moves in the ethers  $\omega_B = \frac{mv^2}{h}$ , close to the natural frequency of oscillation of the particle  $\omega_S = \frac{mc^2}{h}$ , resonance occurs. Resonance is accompanied by an increase in the additional mass of the particle:

$$\Delta m = \hbar \omega_S / c^2 \quad (24)$$

The standard graph of the dependence of the particle's mass on its speed is now simply half the amplitude-frequency characteristic of the forced oscillations of a harmonic oscillator with no dissipation, and the mass growth is absolute [9].

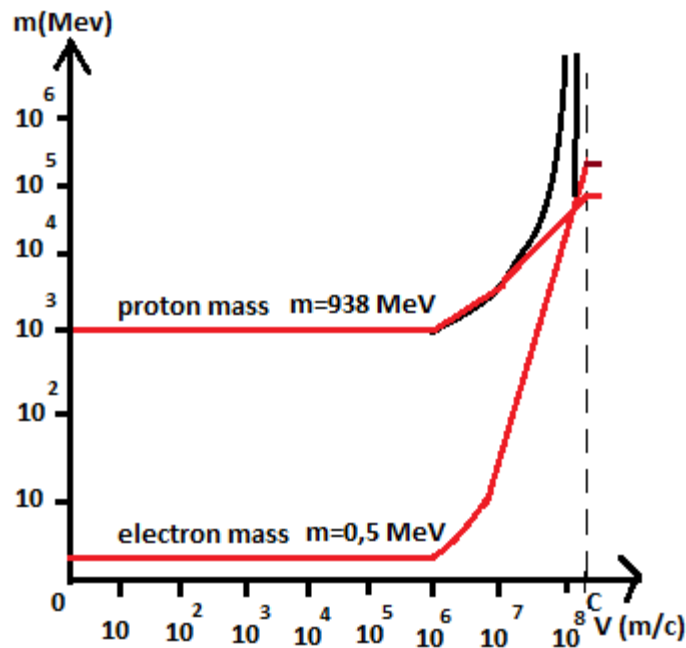

Figure 5

The standard graph of the dependence of the particle's mass on its speed at  $v \rightarrow c$   
 Red color denotes the resonance dependence of the particle's mass at  $v \rightarrow c$   
 Black color denotes the relativistic dependence of particle's mass at  $v \rightarrow c$ .

The frequency corresponding to the resonance energy of the electron ( $\nu$ ) at  $v \rightarrow c$  and wavelength ( $\lambda$ ), and the precession frequency of the rod vortex dipole dark energy ( $\omega$ ) (electron - positron) define as the frequency of the wave function of Schrödinger and de Broglie (at resonance they describe the same probability density of finding a particle at any point in space):

$$\nu = W / h \text{ or } \omega = W / \hbar \text{ and } \lambda = 2\pi s / \omega$$

where  $W$  - the photon energy  
 $h$  - Planck constant  $h = 6.6260 \cdot 10^{-34} \text{ J / Hz}$   
 $\hbar = h / (2\pi) \quad \hbar = 1,0546 \cdot 10^{-34} \text{ J / Hz}$   
 $c$  - the speed of light  $c = 299792458 \text{ m / s}$

The maximum increase in the electron's mass at  $v \rightarrow c$  takes place at resonance ( $\omega_r = 3 \cdot 10^{25} \text{ Hz}$ ) and exceeds the electron's mass (their number) at energy 1 MeV  $\approx 10^5$  times [8].

It turns out that the energy calculation accelerators fundamentally not true? It was assumed that the "relativistic" increasing the mass of charged particles determine by the equation:

$$m_\nu = \frac{m}{\sqrt{1 - \frac{v^2}{c^2}}} \quad (25)$$

Accordingly, the kinetic energy of charged particles is:

$$W = \frac{mc^2}{2} \quad (26)$$

Due to the fact that in formulas (21 and 25), the mass  $m$  and charge  $q$  are inversely proportional to each other, both formulas describe law the same motion of a charged particle. But the difference here is obtained in

principle, which directly affects the energy calculations accelerators. For example, the maximum kinetic energy of the electron is equal to 0.26 MeV ( $W_e = \frac{m_e c^2}{2}$ ). By increasing the energy of an electron in an accelerator to 0.5 MeV, its mass should increase about 2 times, while increasing the power up to 10 MeV, its mass should increase by 28 times. If the increase in mass of an electron from the particle velocity is determined by the other law, and has a limit associated with the natural frequency of the particle, the growth the electron energy will also stop at this limit. In this case, the amplifier consumes no energy to increase the mass and thus the electron energy. The amplifier uses energy to compensate for the reduction of the charge. Accordingly, the maximum proton energy is 500 MeV, or 0.5 GeV and create accelerators with energies of 200GeV or 1000 GeV is a difficult task.

Changes of the mass and charge of the particles at  $v \rightarrow c$ , as well as the deformation of the electric field of a moving charge requires further experimental study and corrections the theory accelerators and colliders. The real energy of the protons in opposite flows in the collider should be much less than stated, and the processes of birth of new particles in the collision of protons differ from those predicted theoretically. It should be noted that the acceleration of charged particles to "relativistic speeds", at  $v \rightarrow c$ , gives an interesting and very important effect. The fact is that under such speeds, particles (eg, protons) loses its charge, becomes quasi-neutral and can freely penetrate into matter the target, to overcome

the Coulomb barrier energy. Thus, the particles can initiate nuclear reactions such as the synthesis of heavy elements. An even greater extent this applies to the accelerator opposite flows (colliders), when the colliding particles are quasi-neutral and a potential barrier is virtually absent.

## VII. CONCLUSION

In conclusion, it should be noted that, in spite of the attractiveness of the idea of a man-made sun - a source of unlimited energy, the construction of large power fusion reactors based on the tokamak involves great risk. These risks are caused not only by the lack of a full-fledged theory of electrodynamics that can adequately describe the actual behavior of electric and magnetic fields and currents in a tokamak, but the study of natural fusion reactor, which acts as our sun. Regular solar plasma emissions could destroy all life on our planet, if not for the distance of the Earth, its thick atmosphere and magnetic field. For man-made fusion reactors in the world, protection from such plasma emission is very difficult to create and control the fusion processes in tokamaks is questionable. Each program of nuclear fusion has adjective "controlled", but as a matter of fact there is no control at all. The initial quantity of respondent material is simply very small quite providently we should say. In spite of successes achieved, the head of such a group in England d-r Alan Hibson announces few years ago that not less than 50 should pass before the construction of reactor for demonstration can be ready. Today that point of view becomes generally accepted. Straightforward approach to nuclear fusion used by modern science is absolutely natural because there is no method in the standard quantum mechanics to influence that process. The future of systems of really controlled nuclear fusion will possibly lie not on the path of the primitive and meaningless heating and pressing of the respondent material but on the path leading to the collision of nuclei possessing a small energy and micro adjusted wave function phase. That is possible in principle by the superposition of controlling external electromagnetic field on the reactive system containing order atoms of deuterium and free deuterons. The special atomic lattice geometry may produce the same characteristics. Dispersion of a deuterons flow due to diffraction on such lattice will result in automatic selection of deuterons in energies and phases. In future models of the reactors in contrast to all existing projects will react in any moment of time only the smallest part of deuterons automatically selected relative to initial phases. It could be possible to obtain in result the small energy generating during long period of time until the reserve of light reacting nuclei will not be exhausted. That cold nuclear fusion does have the right to be called "controlled" [9]. Found A.Penziaom and R. Wilson thermal background radiation of the universe in the microwave range 10 GHz - 33GGts,

made unreasonably received in astrophysics called "relic". It can be a process of cold fusion occurring in the space environment from the release of energy sufficient to raise the temperature of the universe to 2,7K. Nuclear fusion occurs when a charged particle overcomes the repulsive Coulomb barrier and enters the region the nuclear forces of attraction. To implement tunneling, a particle must approach the potential barrier in the phase when the amplitude of the wave packet is small and the particle in the absence of the charge overcomes the barrier, "not noticing" it. In another phase, when the amplitude of the wave packet is large, nonlinear interaction begins and the particle can be reflected from the barrier. From the standpoint of the Unitary Quantum Theory (UQT) Professor L.Sapogina motion of electrons in the tunnel junctions may occur even at very low temperatures [9]. This is confirmed by the experiments of American scientists, who managed to fix the tunnel junctions near the absolute zero of temperature (in liquid helium). [10] Based on the equation UQT Sapogin possible to determine the optimal conditions for the realization of nuclear fusion processes at sufficiently low temperatures. In nuclear reactors of the future the question of magnetic confinement of hot plasma will be no longer relevant. Nature is inexhaustible, it offers a variety of options for power generation, it is fusion reactors stars and cold fusion with the release of subtle heat in outer space of the universe, the choice of the man.

## REFERENCES RÉFÉRENCES REFERENCIAS

1. Aksenov V.V., Non-force and force the magnetic field, M: Russian Physics Journal, Vol. 59, N3, 2016
2. Aksenov V.V., The toroidal decomposition of the vector potential of a magnetic field and its application, M: Moscow University Physics Bulletin, N6, 2015
3. G.V.Nicolaev, Modern electrodynamics and reasons for its paradoxical nature. Prospects to make consistent electrodynamics. Theory, experiments, paradoxes. , Tomsk: Politechnical University, 2003
4. Feynman R., Leighton R., Sands M. ,The Feynman Lectures on Physics, Vol. 6, - M.: Mir, 1977.
5. Danos M., Aharonov-Bohm effect, quantum mechanics electrical transformer. Physics abroad, Serie B, Moscow: Mir, 1984
6. K.J. von Vlaenderen and A.Waser, Generalization of classical electrodynamics to admit a scalar field and longitudinal waves , Hadronic journal, 24, 609-628, 2001.
7. Ageev IM, Shishkin GG, longitudinal waves, Moscow: MAI, 2014.
8. Konstantinov S.I., Cosmic Medium (Collection of articles), – Lambert Academic Publishing, Deutschen Nationalbibliothek, Deutschland/ Germany 2016.

9. Sapogin L.G., Ryabov, Yu. A., Boichenko V.A., Unitary Quantum Theory and a New Source of Energy, Geneva, NY, USA: Archer Enterprises, 2005, second edition, 2015.
10. K.Liharev, T.Klaeson. Scientific American, #8, 1992.
11. Rykov A.V. "Fundamentals of the theory of ether", Moscow: Russian Academy of Sciences, Institute of Physics of the Earth, 2000.





GLOBAL JOURNAL OF SCIENCE FRONTIER RESEARCH: A  
PHYSICS AND SPACE SCIENCE  
Volume 16 Issue 6 Version 1.0 Year 2016  
Type : Double Blind Peer Reviewed International Research Journal  
Publisher: Global Journals Inc. (USA)  
Online ISSN: 2249-4626 & Print ISSN: 0975-5896

# Management Photoluminescence and Electrical Properties of the Double-Barrier Structure based on Silicon Gamma - Rays and Radiation Defect

By F. P. Abasov

*Institute of Radiation Problems Azerbaijan National Academy Science*

**Abstract-** Developed and analyzed two-barrier structures - silicon-based photo detectors with high sensitivity in the field of integrated short-range. Developed silicon-based photo detector with high sensitivity integrated in the short range. The effect of gamma radiation on the mechanism of current transport in the structure type Schottky barrier, and in the p-n junctions. It is shown that the double-barrier structure can improve the photovoltaic parameters of conventional detectors. We studied the effect of gamma radiation on the origin of the current mechanism in the structure as a whole, and in the Schottky barrier in the p - n - transitions separately. Also studied the effect of radiation on the photoelectric and photoluminescence parameters of the two barrier structure. Shown that two barrier structures can improve the photoelectric parameters of conventional detectors.

**Keywords:** *silicon based fotoreceiver, double barriers structures, photovoltaic conventional detectors.*

**GJSFR-A Classification:** FOR Code: 020399p



*Strictly as per the compliance and regulations of :*



# Management Photoluminescence and Electrical Properties of the Double-Barrier Structure based on Silicon Gamma - Rays and Radiation Defect

F. P. Abasov

**Abstract-** Developed and analyzed two-barrier structures - silicon-based photo detectors with high sensitivity in the field of integrated short-range. Developed silicon-based photo detector with high sensitivity integrated in the short range. The effect of gamma radiation on the mechanism of current transport in the structure type Schottky barrier, and in the p-n junctions. It is shown that the double-barrier structure can improve the photovoltaic parameters of conventional detectors. We studied the effect of gamma radiation on the origin of the current mechanism in the structure as a whole, and in the Schottky barrier in the p - n - transitions separately. Also studied the effect of radiation on the photoelectric and photoluminescence parameters of the two barrier structure. Shown that two barrier structures can improve the photoelectric parameters of conventional detectors. The photo detector on the basis of silicon with the increased integrated sensitivity in short-wave area of a range is developed. Influence radiation scale on the mechanism of a currents of both in structure like Schottky's barrier, and in p - n - transitions is investigated. It is shown that two-barrier structures allow to improve photo-electric parameters of traditional detectors. Investigated the impact of radiation on the photoelectric and photoluminescence parameters of two-barrier structures.

**Keywords:** silicon based fotoreceiver, double barriers structures, photovoltaic conventional detectors.

## 1. INTRODUCTION

First obtained and investigated characteristics of double-barrier structures created on the same plane. Shown advantages over conventional structures. First obtained and investigated characteristics of double-barrier structures created on the same plane. Shown advantages over conventional structures. With the introduction of the second barrier increases the integral sensitivity in photodiode ( $\beta + 1$ ) times speed and 300 times in the structure. Non-ideality coefficient  $\beta = 1.35$  is small, due to the presence of an electrical field that is due to the drift mechanism in contact with the environment. UV radiation, for example, the case is being investigated jointly with the celebration structure. The influence of gamma radiation on the mechanism of current flow in the structure type Schottky barrier, and the p-n junctions. It is shown that

the double-barrier structure can improve the photoelectric parameters of conventional detectors. Silicon photo detectors, still the most widespread type of photo converters. One of the main directions of increase of speed and increase in spectral sensitivity of modern receivers of radiation with one transition is creation of multi barrier structures. in which thanks to internal strengthening and growth of coefficient of collecting of the photo generated carriers - it is possible to improve significantly key parameters which meet the requirements and needs of optoelectronics. Reliability of work of the received structures under the raised conditions of radiation, as detectors of ionizing radiation is an actual task and makes a subject of our researches.

Recently for expansion of area of spectral sensitivity methods [1, 2] bringing to photocurrent growth in short-wave area of a range are widely used. Example can is – Verizon band structures; pulling fields, etc., based on reduction of speed of a superficial recombination. In our case such opportunity, but in planar execution it is possible to create at the expense of a field n-p-transition included in the opposite direction.

It is showing great interest in the study of photoluminescence features (PL) of short-wave radiation in the visible spectrum for efficiency c-Si-solar cells. Thus, the problem improve efficiency (c-Si) – photo elements consists of two parts: 1 - the re-emission of short-wavelength photons in the visible spectrum edge through the mechanism of direct optical transitions zone-zone silicon monohydrate, 2 - the effective conclusion of photo generated carriers across the spectrum of solar radiation. The forms of the spectra of these emissions, normalized to its maximum value each symmetrical with respect to the line:

$$\nu_s = \frac{\nu_{ex} + \nu_{\xi}}{2} \quad (1)$$

where,  $\nu_{ex}$  - the frequency of the exciting radiation;  
 $\nu_{\xi}$  - frequency fluorescent light.

When excited photoluminescence monochromatic radiation is most likely the appearance of a low-frequency fluorescent light, although it is possible and the emergence of a high-frequency (anti-Stokes) radiation (Fig. 1). The spectra of the Stokes and anti-Stokes photoluminescence emissions. Spectral rules of

*Author:* Institute of Radiation Problems of National Academy of Sciences, Azerbaijan, AZ1143, Baku, str. B.Vahabzade 9.  
e-mail: fpabasov@mail.ru

photoluminescence due to the fact that the absorption of the exciting photon with energy.

$$W_B = h\nu_B,$$

where,  $h$  - Planck constant;  $\nu_B$  - the frequency of the exciting radiation,

$$W_I = h\nu_I,$$

where,  $\nu_I$ - fluorescent light frequency.

The energy difference  $W_B - W_I$  spent on various processes in the material, in addition to photoluminescence. In cases where a photon energy of the exciting radiation is added to some of the energy of the thermal motion of the phosphor particles

$$h\nu_I = h\nu_B + kT,$$

where,  $a$  - coefficient depending on the nature of the phosphor;

$k$  - is Boltzmann constant;

$T$  - absolute temperature of the phosphor, there is anti-Stokes photoluminescence.

The optical properties of the structure dependence  $(\alpha h\nu)^{\frac{1}{2}}$  of  $h\nu$  makes it possible to determine the width of the band gap [4, 6] for the structure.

All of these structures of the optical absorption coefficient of the edge is described by the relation:

$$\alpha h\nu = B(h\nu - E_0)^2 \quad (2)$$

where,  $\alpha = 510^4 \div 10^5 \text{cm}^{-1}$ .  $E_0$  - optical band gap for each film.  $B$  - coefficient of proportionality. The value is determined by extrapolation

Depending  $(\alpha h\nu)^{\frac{1}{2}}$  of  $h\nu$  for each sample. The quadratic dependence (2) obtained theoretically for Tauc model [7-9], which describes the density of states of the mobility gap.

## II. CONCLUSIONS

Thus, it can be argued that the main role in the electrical losses studied silicon structures play oxygen centers ( $V_2 + O$  and  $V + O$ ). With increasing irradiation dose, and the annealing temperature increases, especially CVC and due to the change of spectral characteristics resistance n-Si (the base region of the structure) caused by the accumulation (increasing dose) and the disappearance or rearrangement (for annealing), radiation-induced defects. Known that the defect capture rate electrons and (or) the hole in the first place depends on the capture cross section and the position of the energy level in the forbidden band. These parameters are essentially the "individual" characteristic defect [6, 9]. Upon annealing, the structure is changing the point of radiation defects and their disappearance. In this case mainly the accumulation of similar defects. Comparison with literature data shows that the main role in the photovoltaic losses of these structures play an oxygen centers ( $V_2 + O$  and  $V + O$ ). With further increase of radiation dose an irreversible reduction of photosensitivity due to a significant increase in the resistance base.

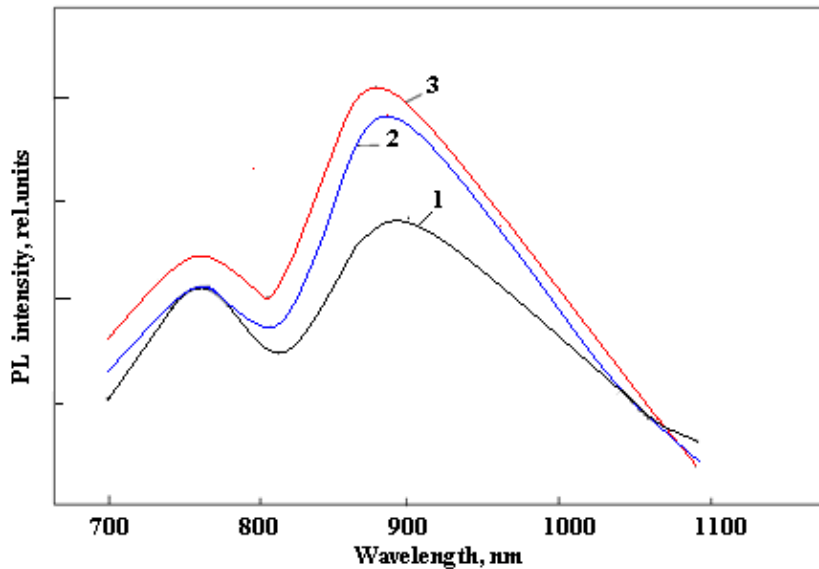

Fig.1: PL spectra of samples irradiated with gamma rays:

1-prior to irradiation, 2-  $D_\gamma=150\text{krad.}$ , 3) -  $D_\gamma=200\text{krad.}$

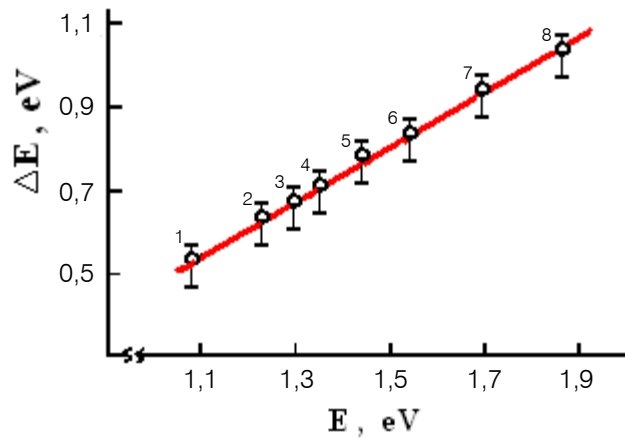

Fig. 2: The dependence of the band gap of the photoconductivity activation energy for the structures Au-(p-n)Si

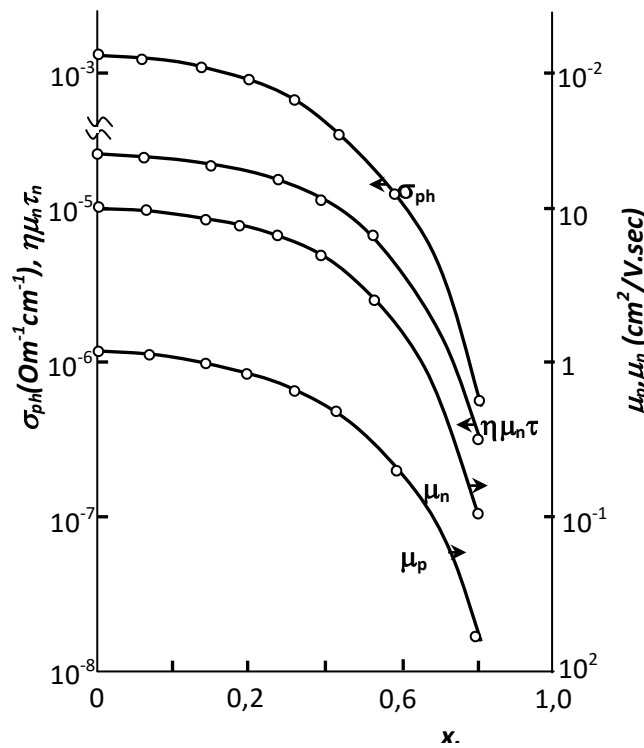

Fig. 3: Dependence of the parameter photoconductivity  $\nu\mu_n\tau\sigma_{ph}$ ,  $\sigma$ , the drift mobility of holes ( $\mu_p$ ) and electrons ( $\mu_n$ ) for Au-Si structures

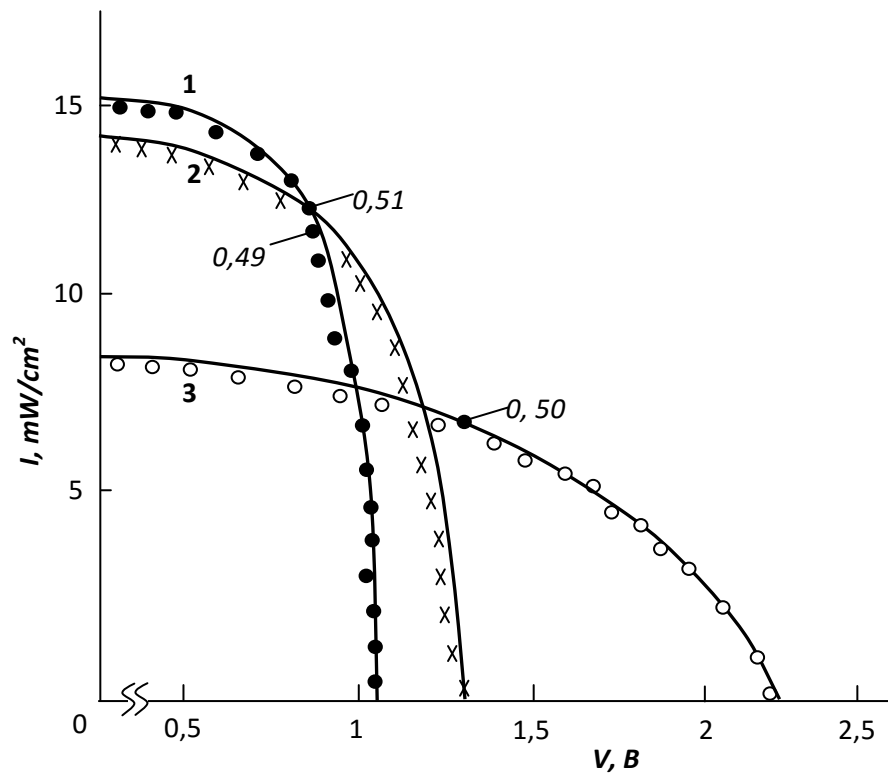

Fig. 4: Characteristics of the double-barrier photo converter with lighting fittings 100 mW/cm<sup>2</sup>

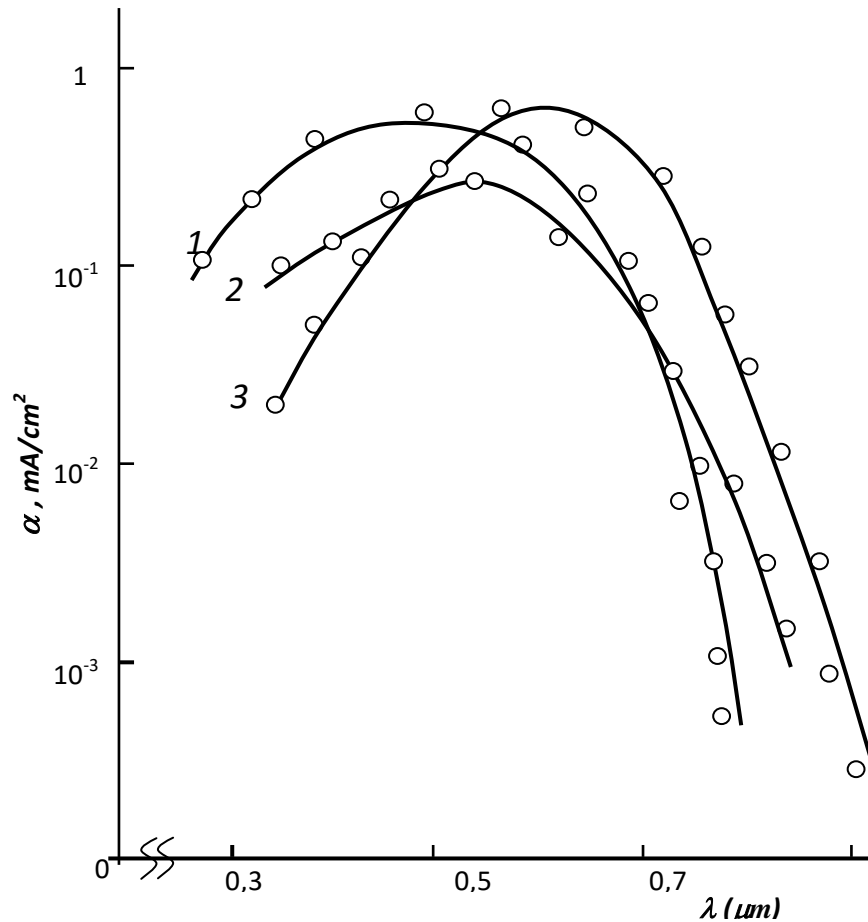

Fig. 5: The dependence of the carrier collection efficiency of the light wavelength for solar cells with p-i-n structure: 1 - double-barrier structure; 2 - p-n junction; 3 - Schottky barrier



GLOBAL JOURNAL OF SCIENCE FRONTIER RESEARCH: A  
PHYSICS AND SPACE SCIENCE  
Volume 16 Issue 6 Version 1.0 Year 2016  
Type : Double Blind Peer Reviewed International Research Journal  
Publisher: Global Journals Inc. (USA)  
Online ISSN: 2249-4626 & Print ISSN: 0975-5896

# Physics and Philosophy of Wave Reference Frames in A Retrospective of 20-th Century Findings and Illusions

By Allan Zade

**Abstract-** Physics of 20-th century based on the most famous theory named Relativity. Postulates of that theory look fine for many decades until the power of measurement devices reach the critical level and they show many “impossible” data coming from them.

This paper gives answers on all questions of those “impossible phenomena” and their relationship with the underlying process of signal propagation in Wave Reference Frame.

**Keywords:** *aurora effect, comprehension horizon, inertial reference frame, relativity, SMA, wave reference frame.*

**GJSFR-A Classification:** FOR Code: 240501p



*Strictly as per the compliance and regulations of :*



# Physics and Philosophy of Wave Reference Frames in a Retrospective of 20-th Century Findings and Illusions

Allan Zade

**Abstract** Physics of 20-th century based on the most famous theory named Relativity. Postulates of that theory look fine for many decades until the power of measurement devices reach the critical level and they show many “impossible” data coming from them.

This paper gives answers on all questions of those “impossible phenomena” and their relationship with the underlying process of signal propagation in Wave Reference Frame.

**Keywords:** *aurora effect, comprehension horizon, inertial reference frame, relativity, SMA, wave reference frame.*

## I. INTRODUCTION

To start research in any area, a researcher needs to define basic categories applicable in the area of research. In case of motion, that determination includes two basic categories of velocity and reference frame.

In common understanding, velocity makes no problem in definition and explanation. The famous equation of velocity shows this.

$$v = \frac{s}{t} \quad (1)$$

It has two variables determining by spatial relocation (S) and duration of the process (usually associated with time, t).

In case of mechanical motion, they determine velocity V of a moving object usually by a two-way test. For example, a fast car uses a measurement mile with two sensors installed at the beginning and the end of the mile.

The car runs twice the mile in two opposite directions to reduce an influence of many low-level physical factors like wind, etc. In that case, the car uses the same physical distance (of the measurement mile) by continuing physical interaction of the car and the ground. In other words, the car changes a condition of its internal mechanical elements to go forward. Those changes include motion of the pistons, rotation of the crankshaft, elements of transmission and so on, as well as rotation of wheels which make physical interaction

with the road. The car cannot move without all those internal mechanical motion.

Such observations were known for many ages and led the humankind to the idea of mechanical motion. In case of that motion, relocation of an object becomes possible only by interaction with another object and stops immediately as soon as that interaction brakes.

For example, the car cannot move forward if its wheels make not any interaction with the road because of ice. In that case, ice covers the road and blocks the mechanical interaction between the wheels and the road surface. As a result, the wheels rotate, but the car does not move.

That point of view led to a creation of the paradigm of mechanical motion and became the dominated one in the human mind from the ancient times. Everything looked fine until an ancient engineer had invented a ballista.

A ballista is an ancient heavy missile launcher designed to hurl javelins or heavy balls. A smaller ballista was basically a large crossbow fastened to a mount. The huge and complicated Roman ballista, however, was powered by torsion derived from two thick skeins of twisted cords through which were thrust two separate arms joined at their ends by the cord that propelled the missile. The largest ballistas were quite accurate in hurling 60-pound weights up to about 500 yards. (Ballista. (2008). Encyclopedia Britannica)

The mechanical paradigm has not any explanation of ballista operability because the mechanical interaction between the device and the ball ends as soon as the ball leaves the ballista. In that case, according to the mechanical paradigm, the ball should drop down right in front of ballista without any chance “to be hurled up to 500 yards”.

Some ancient thinkers thought this. The air spreads out in front of the ball hurled from the ballista and shrinks behind the ball. As a result, the air pushes the ball from the back. However, such “explanation” raises one serious question about other objects. They show no motion in the same air. Therefore, the explanation fails its applicability to the physical events.

Moreover, a ballista-man sees motion of the ball staying next to the ballista. He holds his ground physically and philosophically because all his

*Author: Independent Researcher, Rostov-on-Don, Russian Federation.  
e-mail: allanzadeuk@gmail.com*

speculations about motion begin from his *immovable location next to the ballista*.

No one of them associated himself with the ball hurled from the ballista because no one of them can image his motion riding the hurled ball. A new problem appeared here as soon as *an engineer crushed a theoretical framework of philosophers*.

## II. THE REFERENCE FRAME PROBLEM

A ballista-man associated himself with the ballista started the problem of the observer. He observes all events related to the ballista from his location next to the same ballista.

As a result, he says this. "The largest ballistas were quite accurate in hurling 60-pound weights up to about 500 yards" (see above). No one of them says another idea that "The 60-pound weight hurls the ballista up to about 500 yards." Such statement looks weird at first glance because the discussing process involves mechanical interaction with one more massive object that we call Earth.

Strictly speaking, every mechanical interaction appears at some level as interaction with the Earth. Therefore, the mechanical paradigm works fine only in case of final reduction of all mechanical interactions to mechanical interaction with the Earth.

For example, a ballista-man makes the following statement. "A ballista hurls a ball." That statement looks correct, but it is wrong. The ballista makes interaction with two objects in that process. Those are the ball and the Earth because the ballista installed firmly on the ground. As a result, the ballista makes interaction with the ball and keeps mechanical interaction with the Earth during the process of hurling. The observer who stays on the ground next to the ballista maintains mechanical interaction with the Earth too.

That mechanical interaction causes the fixed location of the observer and the ballista before, during and after the process of hurling. As a result, the observer falls under an oppressive illusion that only the ball moves relative to the ballista and all other objects remain static during the process of hurling.

That point of view became dominated one for many centuries. The Earth became the center of the Universe "because it is so heavy that it cannot move anywhere." In that paradigm, every motion appears only as relative motion to the Earth surface. That surface can be easily found everywhere, and the problem looks like solved one for many centuries.

From that point of view, all objects fall into two groups of "immovable" objects and "movable" one. Later, a *logical generalization* of all objects staying immovable relative to the observer during an experiment forms *the Observer-Bound Reference Frame (OBRF)*.

A reference frame, also called frame of reference, in dynamics, is a system of graduated lines symbolically attached to a body that serve to describe the position of points relative to the body. The position of a point on the surface of the Earth, for example, can be described by degrees of latitude, measured north and south from the Equator, and degrees of longitude, measured east and west from the great circle passing through Greenwich, England, and the poles. (Reference frame. (2008). Encyclopedia Britannica)

It is easily noticeable that a reference frame (here and later - RF) has a strong relationship with a body by definition. In other words, an observer should determine "the object" to apply a reference system to it. As a result, it looks impossible to make a *reference frame without an object by definition of a reference frame*.

That point of view raised a huge problem of comprehension since the time of Copernicus. The idea that the Earth moves relative other celestial bodies looked weird for the Earth population for many decades. The humankind lost the notion of "absolute rest" for the first time.

The problem comes from the human philosophy and the paradigm of mechanical motion that explains every motion in a relationship with the Earth surface. As soon as the Earth becomes movable, every motion becomes relative to some other "reference frame associated with another celestial body that can be used as the body at rest."

The problem persisted for a few centuries until Sir Isaac Newton introduced his point of view by means of forces which come from a new paradigm of physics.

## III. THE AGE OF NEWTON

Newton was involved in solution of the celestial mechanic's problem that comes from motion of celestial bodies

The formulation of the law of gravitation was his best achievement. That law led to some consequences in physics which changed imagination of reference frames. According to the law of gravitation, every celestial body makes interaction with every other celestial body by some force. That force is independent of direction and depends on masses of the bodies and distance between them.

The result of that interaction appears in the form of a deviation of a trajectory from the straight line. In case of enough magnitude of interaction, a trajectory of a celestial body comes to an ellipse. As a result, a body with lesser mass becomes a satellite of a body with greater mass.

That point of view explained motion of the planets of the Solar System around the Sun and put the Sun in the center of the Universe. In other words, that



way has created a *new reference frame* associated with another (motionless) celestial body (the Sun).

Everything looks fine at the beginning until “fixed stars” become movable. Humankind faced the same problem again. The “fixed ground” for all human-made speculations disappeared again as a mist among billions of stars of the Universe.

The situation became critical for the humankind and its philosophy because a human-made point of view on the Universe needs something “at rest” at every point in space as the earth surface to the earth-bound observer. Otherwise, the situation becomes terrible because an absence of such thing at rest eliminates the idea of motion. In such case, an observer can take the Sun or a planet as the origin of the reference frame and make all observations in his reference frame in complete disagreement with other observers. Celestial mechanics and physics would be paralyzed that way.

For example, an observer on every planet can take his planet as the origin of a reference frame and describe motion of all other bodies around the planet. Strictly speaking, the law of gravitation becomes false in this situation because it can be proven only by comparison of masses of the celestial bodies. Otherwise, an observer takes any celestial body with lesser mass, treat it as the origin of the reference frame and see how a body with higher mass changes its trajectory around the body with lesser mass.

In other words, that situation comes back to the observation of a ballista-man. The observer (the ballista-man) can describe motion of the hauling ball only if he associates himself with a ballista instead of a ball. That idea supports the same comparison of masses. Otherwise, a ball-bound observer describes motion of the earth and all other things on the earth surface in the ball-bound reference frame after interaction of the ball and the ballista.

Worse than that, in case of gravitation, that ball-bound observer makes an observation of “the Earth falling on the ball by gravitational interaction between two bodies (the Earth and the ball).”

Those two observers can fight for ages defending observations in two different reference frames until they conduct an edge experiment that shows the preferred reference frame to them. What is an edge experiment?

*An edge experiment in a given area of science is the experiment that uses a different way of experimentation and shows a different data, unlike other experiments in the same area of science.*

(Statement A)

In case of observers mentioned above, they use two other observers to conduct an edge experiment. Those are another ballista-man and another ball-bound observer.

The experiment begins. Two ballista hurls two balls in different directions at the same time. Two ballista men reported motion of balls relative to each ballista. Two ball-bound observers reported motion of the Earth surface in some direction.

In that case, observations of ballista men become compatible with each other because they share the same Earth-bound reference frame.

Unlike them, observations of both ball-bound observers remain correct for a given observer but become contradictory in comparison with the view of another ball-bound observer.

Comparison of their observations leads to this. The Earth surface moves in two different directions *simultaneously* after ballista-ball interaction. Such observations lead to a physical *controversy* because a physical object keeps only one condition of motion at a given moment. For example, a rotating object remains one and only one axis of rotation. It is physically impossible for an object to keep more than one axis of rotation at a given moment.

The same statement is correct about motion. The same object keep only one way of motion because a physical object has only one location at a given moment. Therefore,

*If two or more observers “detect” simultaneously different conditions of motion of the same physical object then they use different reference frames in condition of relative motion to each other.*

(Statement B)

In case of two balls mentioned above, those observers determine their mutual motion because they “detect” more than one condition of motion of the same physical object (the Earth) *simultaneously*.

That conclusion terminates they fight about the best reference frame because

*In case of many reference frames, the best one reduces controversy in observation of motion of any observer by determination of motion of the same observer regarding that reference frame.*

(Statement C)

In other words, all controversies caused by any number of ball-bound observers moving relative to the Earth can be eliminated by the introduction of the earth-bound reference frame. That reference reframe is the better one for them because it destroys all illusions of motion of those observers.

The *implicit* application of the same method led Newton to the idea about better reference frame for the Solar System where the Sun should be used as the point of origin of the better reference frame. That reference frame eliminates all problems in understanding of planetary orbits and gives the easiest way of calculation of mutual location of any planet to any other one by their location in the same reference frame

instead of two different planetary-bound reference frames.

The next step was done in research of waves.

#### IV. THE IDEA OF WAVE

There is one more way of motion known in physics. That is a propagation of waves. The easiest wave can be found in water.

A wave on a body of water is a ridge or swell on the surface, normally having a forward motion distinct from the oscillatory motion of the particles that successively compose it. (Wave. (2008). Encyclopedia Britannica.)

As soon as a wave makes motion (or propagation) location of wave changes continuously and looks similar to motion of an object. Suppose this. A wave and an object use the same direction of motion. Is it possible to apply equation (1) to a wave? It looks like the question has an obvious positive answer. However, there is a complex meaning of an "obvious" answer.

The equation (1) has not any restriction in a thing that was involved in measurement. In other words, the mentioned equation shows some mathematical abstraction (as any other equation) that distinguishes the equation from the physical world and physical entities. An observer can determine the speed of a wave using that equation, but he faces one major problem.

In case of the Earth surface, location of an object and its motion can be easily traced by a mutual location of the object and a lot of other objects. All those objects have physical interaction with the Earth and keep their locations continuously without any change regarding the Earth surface. Therefore, the Earth surface can be used easily as a reference frame. Researchers used that advantage for ages to conduct a lot of experiments on the Earth surface. Some of them include determination of speed of waves in various substances (and in water in a particular case).

To make a measurement of the speed of a wave in a given substance they put a wave source in a tank filled with that substance. That easy operation has one hidden side effect.

*A motionless substance in a tank shares the same Earth-bound reference frame for the signal and the observer.*

(Statement D)

*In other words, to conduct any speed measurement experiment an observer explicitly brings a given substance in his Earth-bound reference frame.*

That operation looks so "obvious" that no one pays any attention to it. However, that means "unification" of reference frames.

*Unification of reference frames means the operation of determination their reciprocal motion and orientation.*

(Statement E)

Strictly speaking any knowledge of motion of a given thing in a moving reference frame becomes reachable only in Unified Reference Frames (URF). If a researcher fails to make unification of reference frames then he fails any understanding of motion regarding the observer-bound reference frame.

The two balls example mentioned above is the best one that shows a failure of unification of two ball-bound reference frames that raises a controversy in description and understanding of motion. Therefore,

*Unification of given Reference Frames is possible only by a Preferred Reference Frame (PRF) at rest that incorporates other Moving Reference Frames (MRF).*

(Statement F)

Otherwise, observers reach unsolvable controversies in any attempt to detect or describe/comprehend motion. Therefore, URF by an isolated motionless volume of a given substance helps an observer to use his instruments in a lab for signals as well as for all other things including physical objects.

In that case, the observer "detects" and "understands (comprehends)" motion of the signal in observer-bound reference frame (OBRF) as any other motion *in the same reference frame*.

That point of view is so "obvious" that an observer dislikes to make any analysis of physics beyond his measurements and falls under some critical illusions.

The first illusion is the illusion of a reference frame (or Reference Frame Illusion, RF-I). The observer comprehends the observer-bound reference frame as the only one RF that is possible to exist in a signal propagation measurement.

He thinks this. The signal moves *relative to his measurement device* (a ruler for example) but he forgets another thing that a signal exists only in an *artificial* environment of a lab and such motion of a signal becomes a result of application of the observer's point of view on the measurement.

Strictly speaking, a signal in a tank makes propagation through a given medium regardless of presence or absence of an observer. The signal just makes physical interaction with a given medium and spends some duration to cover some distance. Moreover, a signal as a wave follows Huygens' Principle.

In most real cases, a wave originating at some source does not move in a straight line but expands in a series of spherical wave-fronts. The fundamental mechanism for this propagation is known as Huygens' Principle, according to which every point on a wave is a source of spherical waves in its own right... The insightful point suggested by the Dutch physicist Christiaan Huygens is that all the wavelets form a new

coherent wave that moves along at the speed of sound to form the next wave in the sequence. In addition, just as the wavelets add up in the forward direction to create a new wave-front, they also cancel one another, or interfere destructively, in the backward direction, so that the waves continue to propagate only in the forward direction. (Sound. (2008). Encyclopedia Britannica)

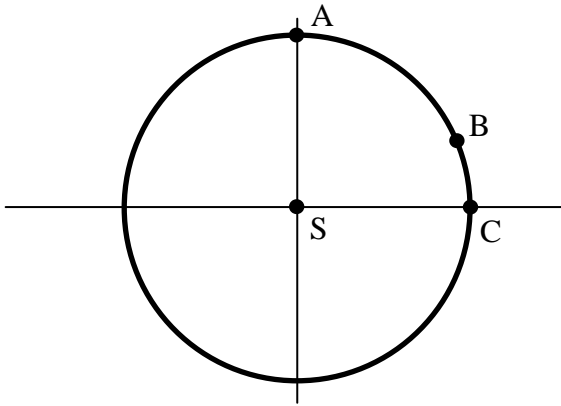

Fig. 1

That is the second illusion of the observer who mistakes the *spherical motion of the wave-front with a linear motion of an object along the ruler.*

Fig.1 shows Huygens' Principle graphically. The point S is the source of wave signal in the figure. The circle ABC shows a location of the wave front after some duration of wave propagation in a medium. According the figure, the same wave-front becomes detectable *simultaneously* at every point of the circle ABC and others because the wave-front reaches those points with *physical simultaneity*.

Strictly speaking, an observer mentioned above, uses only one direction of wave propagation (SA, for example) and pays no attention to other directions of wave propagation like SB, SC, and others. In other words, he *reduces spherical wave propagation to linear propagation*. Why does it happen?

In case of a physical object, it moves along the ruler that an observer uses to detect and determine motion shown by continuously changing location of the object that the observer comprehends as motion in the observer-bound reference frame.

In case of a signal, the signal moves along the ruler that an observer uses to detect and determine motion shown by continuously changing location of the signal wavefront that the observer comprehends as motion in the observer-bound reference frame. In other words,

*An ordinary observer comprehends motion only as a linear relocation of a given thing in an observer-bound reference frame.*

(Statement G)

That point of view leads to serious consequences explained in the next section.

## V. THE INERTIAL REFERENCE FRAMES

Newtonian mathematics needs a specific reference frame to be applicable in that frame.

Strictly speaking, Newton's laws of motion are valid only in a coordinate system at rest with respect to the "fixed" stars. Such a system is known as a Newtonian, or *inertial reference, frame*. The laws are also valid in any set of rigid axes moving with constant velocity and without rotation relative to the inertial frame; this concept is known as the principle of Newtonian or Galilean relativity. A coordinate system attached to the Earth is *not an inertial reference frame because the Earth rotates and is accelerated with respect to the Sun*. Although the solutions to most engineering problems can be obtained to a satisfactory degree of accuracy by assuming that an Earth-based reference frame is an inertial one, (reference frame. (2008). Encyclopedia Britannica)

Newton's first law states that, if a body is at rest or moving at a constant speed in a straight line, it will remain at rest or keep moving in a straight line at constant speed unless it is acted upon by a force. This postulate is known as the law of inertia. (Newton's laws of motion. (2008). Encyclopedia Britannica.)

The best example of such motion is gun-bullet interaction. Suppose an observer has a charged gun. The gun and the bullet inside the gun follow the law of inertia because both objects remain at rest and keep zero speed in an observer-bound reference frame. Moreover, their trajectories coincide in that reference frame.

The experiment begins. The observer aims the gun at a target and shoots. The bullet in the gun possesses some acceleration by chemical reaction of the load that pushes the bullet out of the gun by the barrel. As soon as the bullet leaves the barrel, the pressure of gases that pushes the bullet forward drops to zero. As a result, acceleration of the bullet drops to zero as well. The gun and the bullet come again to the observer-bound *inertial reference frame*. In that condition the bullet keeps motion along a straight line until another force (of impact) changes its velocity. Figure two shows that case graphically.

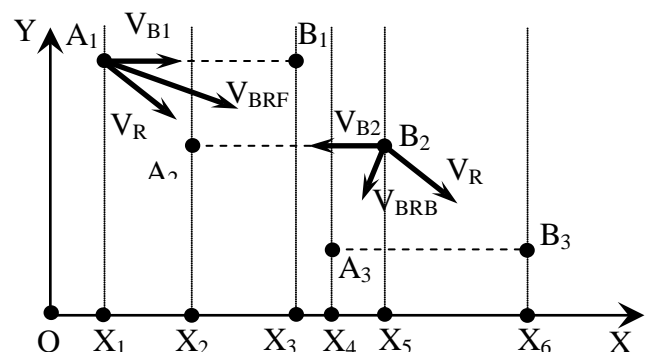

Fig. 2

There are three observers A, B and O represented in the figure by their points of location. Observers A and B have their original positions  $A_1$  and  $B_1$ . They are located motionlessly to each other. Each observer also has a gun identical to the gun of another observer.

The experiment begins. The observer A shoots a bullet toward the target located next to the observer B. The bullet covers the distance  $A_1B_1$  in a duration  $D_{A_1B_1}$ . The observer A calculates the speed of the bullet by the equation (1) and has the result  $V_{B_1} = S_{A_1B_1}/D_{A_1B_1}$ .

The observer B makes the same test shooting a bullet toward the target located next to the observer A. The bullet covers the distance  $B_1A_1$  in a duration  $D_{B_1A_1}$ . The observer A calculates the speed of the bullet by the same equation (1) and have the result  $V_{B_2} = S_{B_1A_1}/D_{B_1A_1}$ . In that case, both observers agree that the speed of a bullet in both directions equal to each other ( $V_{B_1} = V_{B_2}$ ).

Moreover, the observer O that keeps motionless location during both experiments agrees with the point of view of the observer A and the observer B because all observers share the same reference frame.

The next experiment uses the observer O in motion. That observer makes some acceleration and possesses some velocity that appears as  $V_R$  or velocity of the reference frame associated with the observer O.

Observers A and B make the same tests again. In that case, the observer O detects motion of the bullet toward the observer B as motion by the trajectory  $A_1B_2$ . Despite greater distance ( $A_1B_2 > A_1B_1$ ) the experiment shows the same duration of the bullet travel to the target. That happen because

*A physical object has the only one value of any physical attribute at a given moment.*

(Statement H)

That means the basis of physical measurements. If an object shows more than one value of the same attribute *simultaneously*, physical measurements become impossible.

The observer O understands this. The trajectory  $A_1B_2$  appears as a result of his motion relative to observers A, B, and the bullet. All those elements "affected" by his relative velocity  $V_R$  and show some trajectories that exist *only in the reference frame bound to the observer O*. Moreover, all velocities are also affected by the same velocity  $V_R$ . As a result, the observer O detects some "projection" of physical motion of other objects on his reference frame.

As a result, motion of the observer O has no impact on duration of experiment in other reference frame because that motion makes not any physical interaction with anything in another reference frame. Moreover, appearance of the reference frame bound to the observer O depends on previous acceleration of the observer O. Therefore, that reference frame depends on

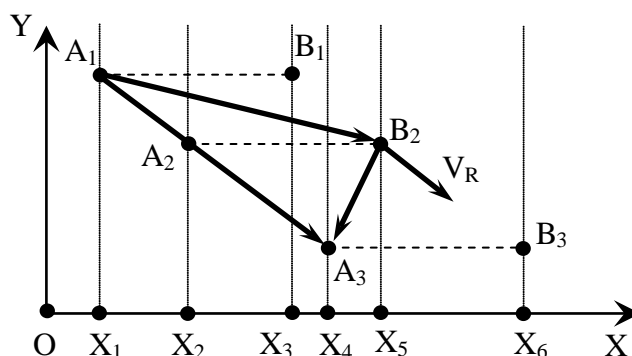

Fig. 3

some force applied to the observer O without any changes in motion of other physical objects. In other words,

*A physical action applied to an observer does not change condition of other physical objects*

(Statement I)

Therefore, the bullet experiment mentioned above is independent of any number of observers and their inertial frames created after acceleration finished its action (acceleration is applied to a given observer).

In other words, every observer creates his inertial reference frame as soon as the observer stops acceleration applied to him. That way of thoughts led Newton to the idea of an infinite number of *comparable inertial reference frames* (or URF) which describe any motion by recalculation regarding their relative velocities.

Everything looks fine, and Sir Isaac Newton became a famous person of his time. The situation had no changes until wave nature of light was confirmed.

## VI. THE WAVE REFERENCE FRAME

Huygens, Christiaan (also spelled Christian Huyghens, born April 14, 1629, The Hague died July 8, 1695, The Hague) was a Dutch mathematician, astronomer, and physicist, who founded the wave theory of light, discovered the true shape of the rings of Saturn, and made original contributions to the science of dynamics—the study of *the action of forces on bodies*. (Huygens, Christiaan. (2008). Encyclopedia Britannica.) Later research made by another scientist James Clerk Maxwell led him to formulation of his famous equations.

"A manipulation of the four equations for the electric and magnetic fields led Maxwell to wave equations for the fields, the solutions of which are traveling harmonic waves. Though the mathematical treatment is detailed, the underlying origin of the waves can be understood qualitatively: changing magnetic fields produce electric fields, and changing electric fields produce magnetic fields. This implies the

possibility of an electromagnetic field in which a changing electric field continually gives rise to a changing magnetic field, and vice versa.

“Electromagnetic waves do not represent physical displacements that propagate through a medium like mechanical sound and water waves; instead, they describe propagating oscillations in the strengths of electric and magnetic fields. Maxwell's wave equation showed that the speed of the waves, labeled  $c$ , is determined by a combination of constants in the laws of electrostatics and magnetostatics—in modern notation:

$$c = \frac{1}{\sqrt{\epsilon_0 \mu_0}} \quad (2)$$

“Where  $\epsilon_0$ , the permittivity of free space, has an experimentally determined value of  $8.85 \times 10^{-12}$  square coulomb per newton square meter, and  $\mu_0$ , the magnetic permeability of free space, has a value of  $1.26 \times 10^{-6}$  newton square seconds per square coulomb. The calculated speed, about  $3 \times 10^8$  meters per second, agreed with the known speed of light.” (Light. (2008). Encyclopedia Britannica.)

They had a lot of attempt to determine the speed of light. One of early attempt includes the following experiment.

“Measurements of the speed of light have challenged scientists for centuries. The assumption that the speed is infinite was dispelled by the Danish astronomer Ole Rømer in 1676. French physicist Armand-Hippolyte-Louis Fizeau was the first to succeed in a terrestrial measurement in 1849, sending a light beam along a 17.3-km *round-trip path* across the outskirts of Paris. At the light source, the exiting beam was chopped by a rotating toothed wheel; the measured rotational rate of the wheel at which the beam, upon its return, was eclipsed by the toothed rim was used to determine the beam's travel time. Fizeau reported a light speed that differs by only about 5 percent from the currently accepted value. One year later, French physicist Jean-Bernard-Léon Foucault improved the accuracy of the technique to about 1 percent. (Light. (2008). Encyclopedia Britannica.)

Those experiments gave definite value of the speed of light. However, no one of them answered the question about physical way of light propagation.

“From the first speculations on the wave nature of light by *Huygens* through the progressively more refined theories of *Young*, *Fresnel*, and *Maxwell*, it was assumed that an underlying physical medium supports the transmission of light, in much the same way that air supports the transmission of sound. Called the *ether*, or the *luminiferous ether*, this medium was thought to permeate all of space. The inferred physical properties of the ether were problematic—to support the high-frequency transverse oscillations of light, it would have

to be very rigid, but its lack of effect on planetary motion and the fact that it was not observed in any terrestrial circumstances required it to be tenuous and chemically undetectable.” (Light. (2008). Encyclopedia Britannica.)

That point of view describes clearly the 19-th century paradigm of waves. According to that paradigm, every wave should have *mechanical interaction* with some medium that supports propagation of that wave. Light is not a mechanical wave. Therefore, such restrictions are not applicable to light.

Moreover, equation (2) uses two constants  $\epsilon_0$ , the permittivity of free space and  $\mu_0$ , the magnetic permeability of free space. Both of them have reference to physical attributes of free space and there is not any reference here on any physical attributes of so-called “luminiferous ether”.

That problem led to a serious dispute at the late 19-th century because researchers of that time make measurements of physical attributes associated with free space looking for something beyond that free space.

If they like to make measurements of physical attributes of luminiferous ether they should measure attributes of that ether instead *attributes of space*.

Science meets that situation ever when the humankind meets something from a new paradigm but tries to explain that thing in categories of the old paradigm. In a given case, they try to use categories of a physical substance different from pure space to describe propagation of light waves through space.

That way leads ever to nonplus because old categories do not work in a new paradigm. Sometimes it's hard to a researcher to understand that he faces a new paradigm and his previous experience becomes *entirely inapplicable* to the new paradigm. However, that is a standard task for a philosopher to refine and change categories in his mind to reach categories of another paradigm.

They also raised another question about a reference frame that supports propagation of light. That question seems a strange one because any wave makes propagation regarding the medium that supports propagation of a given wave.

Therefore, if the speed of light depends on known attributes of free space it makes propagation relative to that free space. That easy conclusion looks weird to physicists of the 19-th century because free space has nothing to apply a reference frame in which the speed of light can be determined. All Earth-bound experiments give the only observer-to-light measurement of that value without any reference to the actual speed of light *regarding free space*.

The problem comes from the idea of reference frame by itself and becomes more philosophical than physical. Free space has not any reference for application and orientation of a traditional reference frame in the understanding of 19-th century scientists.

They need a physical object to “attach” a reference frame to it.

As mentioned above, “A reference frame, also called frame of reference, in dynamics, is a system of graduated lines symbolically attached to a body that serves to describe the position of points relative to the body.” That is a cornerstone of 19-th century scientific point of view. To set up a reference frame, they need a body to be associated with that reference frame. Usually, that body becomes the point of origin of the reference frame and orientation of the body sets directions of “graduated lines symbolically attached to a body.” Therefore,

*Application of a reference frame in 19-th century physics paradigm requires a body to serve as the point of origin for the reference frame.*

(Statement J)

A strange question appears here. Is it possible to define a reference frame without any relationship with an object? Such reference frame should remain intact regardless any object and any motion of other physical objects. In other words, that reference frame should be a physical self-consistent reference frame in which any motion depends on pure motion of an object regarding (relative to) that reference frame.

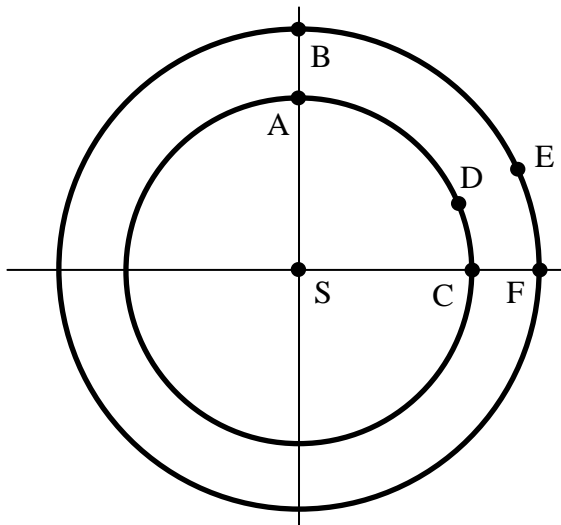

Fig. 4

The existence of such unique reference frame seems impossible at first glance. However, it is physically possible to define that reference frame. Figure one gives the answer on that question.

According to the figure, the body placed in water produces a sound wave at the point S. That wave makes propagation through a given medium (water) and forms the exact sphere at the wave front. The figure four transforms the figure one to a Reference Frame.

The figure four shows propagation of the signal wave front originated at the point S through a given medium (water for example).

This wave front covers the same distance in every direction with the same duration. Therefore, if some observers have a duration measurement device they detect the same wave front simultaneously at the same distance from the point of origin. Moreover, the same wave front spends the same duration to cover the same distance in every direction. That makes the distance AB equal to the distance DE and CF.

In a lab experiment, an observer usually reduces the entire experiment to the propagation of the wave front in a given direction (SF, for example) and forgets other directions of signal propagation. That leads to a serious misunderstanding of some aspects of signal propagation.

Moreover, suppose this. The object crated two different signals at the point S (fig. 4). Each signal has a different speed of propagation in a given medium. As a result, both signals have a different wave front after the same duration of emission.

According the lab observation those signals would be detected at the points A and B simultaneously and the observer has the following conclusion. The signal B that detected at the point B simultaneously with the signal A at the point A has greater speed of propagation in the same medium because it uses the same duration of propagation to cover a greater linear distance from the point of signal emission (S).

It is also possible to determine the ratio of signal speed the following way

$$R = \frac{V_B}{V_A} \quad (3)$$

In other words, if the signal A spends duration D to cover a given distance, the signal B covers R-times greater distance spending the same duration.

Suppose now this. An observer uses a mirror of any kind to reflect the signal inside the medium. According the Huygens' Principle, “every point on a wave is a source of spherical waves in its own right...” Therefore, after reflection, the signal has the same law of propagation as from the source of the signal (S). Figure five shows that case.

There is the source (S) of two signals with different speed of propagation in the same medium in the medium-bound reference frame. The observer S punts the mirror M at the point M and sends both signals in the medium *simultaneously*.

The observer gives signals some duration D to make propagation in the medium. After that he has the situation shown in the figure five. The wave-front of the first signal (the signal A) forms the circle ABC in the figure plane (and the perfect sphere in the medium). Distance between the signal source S and any point of that circle is the same and equal to  $S_A$ .

The wave-front of the second signal (the signal B) spending the same duration reaches the mirror M (at

the point M) makes physical interaction with the mirror, reflects from the mirror and forms the sphere DEF.

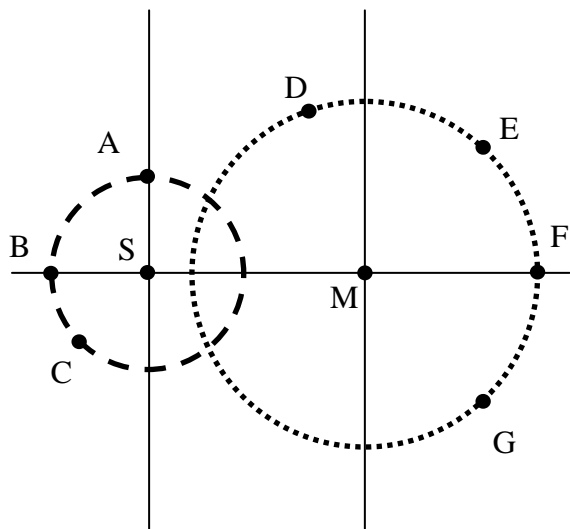

Fig. 5

Those signals follow the equation (3) therefore. Distance covered by wave-front of signals has the same ratio  $R$  despite trajectory that a signal uses.

Strictly speaking, a linear motion of those signals is an illusion of the observer who likes measurements of motion in a linear way by comparison of distance covered by a signal and a physical ruler that an observer uses to make measurements in *his reference frame*.

In general case, a linear trajectory of a signal played no role in the propagation of wave-front of the signal and associated with an observer's point of view that a signal makes propagation in the form of linear rays.

In other words, regarding the figure five, distance  $SMD$  is  $R$  times greater than distance  $SA$  ( $SMD = R(SA)$ ) as well as  $SME = R(SB)$ ,  $SMF = R(SC)$  and etcetera to infinity. Therefore,

*In case of two signals which make propagation regarding the same medium-bound reference frame, a signal that  $R$ -times faster than another signal covers  $R$ -times greater distance in any given duration regardless of trajectories that signals use in that reference frame.*

(Statement K)

In other words, an observer that uses a reflected signal from a mirror uses only a particular case of signal propagation. In general case, the observer can use any number of mirrors with the same result. In any case, a ratio of distances covered by mentioned signals by the same duration of an experiment *keeps constant value*.

Statement K has a logical conclusion for two identical signals in the following way.

*In case of two identical signals which make propagation regarding the same medium-bound reference frame, both of them cover the same distance*

*in any given duration regardless of trajectories that signals use in that reference frame.*

(Statement L)

Statement L helps the observer to determine the full length of a signal path. If two identical signals emitted from the same point simultaneously come back to the same observer simultaneously, then both signals use the same length of their different paths. Paths of those signals can be *different*, but full length covered by each signal (by its wave front) *becomes equal to each other in that case*.

Suppose now this. An observer remains location at the point  $S$  motionless regarding the medium that support propagation of signals (Fig. 6). That is the experiment A.

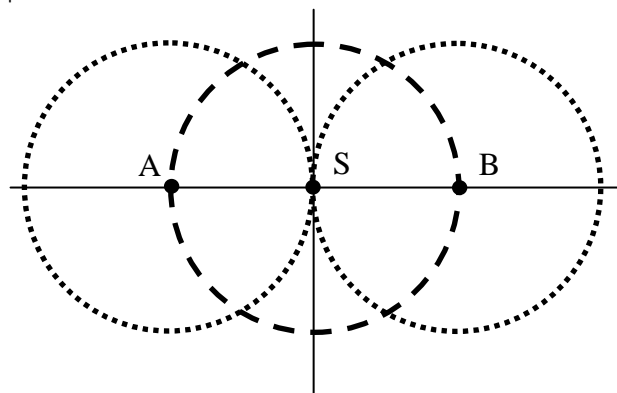

Fig. 6

The observer emits one signal from his point of location. However, that single signal coincides with an infinite number of wave-front points that makes propagation in the medium. Every point of that wave front is independent of other points by Huygens' Principle.

There are also two mirrors located at the points  $A$  and  $B$  equidistant from the point  $S$ . Wave front of the signal reaches both mirrors simultaneously makes physical interaction with them and creates two new signals. Those signals make propagation in the same medium and *the same medium-bound reference frame* as well as the original signal. Each of them has one point of their wave fronts moving toward point  $S$ . Both mirrored (new) signals spend the same duration  $D$  to cover equal distance  $AS$  and  $BS$ . As a result, the observer detects both mirrored signals *simultaneously*.

In that case, the observer falls under an illusion that the experiment gives him an "unavoidable prove" of his motionless location relative to the medium. However, that is only an illusion. Figure Seven explains that illusion.

In figure seven, the observer shares the same straight line with two mirrors  $A$  and  $B$ . Both mirrors located equidistant from the observer during the entire experiment. Unlike the previous case, the observer and the mirrors move in the perpendicular direction to the

straight line that connects them. Figure seven shows some consequent locations of all elements.

Motionless location of both mirrors regarding the observer's *inertial reference frame* (IRF) because no force affect those mirrors. Therefore, they have zero acceleration and keep zero observer-to-mirror speed of relative motion during the experiment. That is the experiment B.

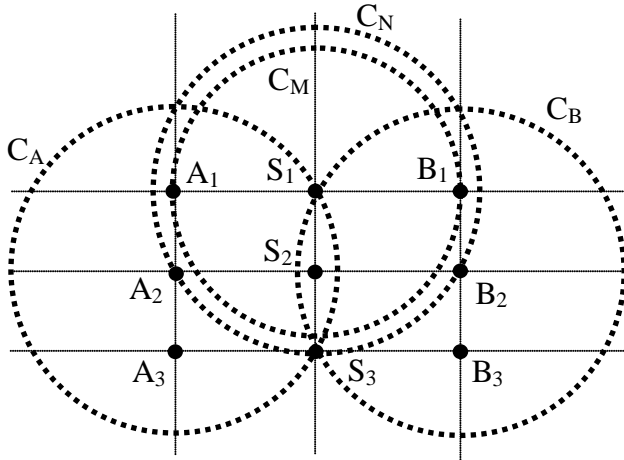

Fig. 7

The observer begins the experiment the same way by emitting a signal in the medium from the point  $S_1$ . The signal spends some duration  $D_M$  to reach points of mirror location in the medium-bound reference frame. Those are points  $A_1$  and  $B_1$ . Everything coincides now with the previous experiment.

The signal does not make any interaction with mirrors at the points  $A_1$  and  $B_1$  because both mirrors move forward with the observer by observer-to-medium

relative motion. The signal forms the circle  $C_M$  at that moment. Therefore, the signal spends some extra duration and reach mirrors at points  $A_2$  and  $B_2$  spending duration  $D_N$  and forming the circle  $C_N$ .

After interaction with mirrors, two reflected signals move by Huygens' Principle again using mirrors as points of origin of two new signals. Those signals reach the observer at the point  $S_3$  *simultaneously*. Therefore, the observer has two reflected signals simultaneously again and become unable to separate his motion relative to the medium in experiment A and B. In other words, the observer is unable to detect his motion relative the medium that way.

Moreover, experiment B has one more side effect. The mirrored signals reach the point  $S_1$  (the original location of the observer at the beginning of the experiment) simultaneously as well as the point  $S_3$ .

In other words, an observer that keeps motionless location relative to the medium-bound reference frame in experiment B (the point  $S_1$ ) detects no difference in the experiment from the moving observer because both observers detect both mirrored signals simultaneously (at points  $S_1$  and  $S_3$ ). Moreover, both observers detect the same duration of the experiment B *equal for*  $2D_N$ .

What is the value of  $2D_N$ ? That is the duration of the signal propagation in "ray mode" that comes from the imagination of the observer. That path appears as wave-front propagation by  $S_1A_2S_3$  trajectory for the mirrored signal A and  $S_1B_2S_3$  trajectory for the mirrored signal B.

In general case, the same observer conducts the experiment C in which the observer and the mirrors have a casual direction of motion in a given medium regarding the straight line connecting the mirrors. Figure eight shows that case.

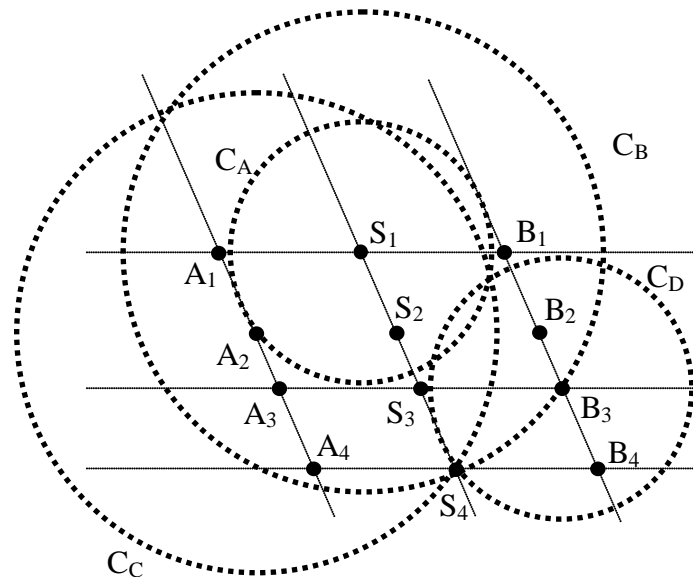

Fig. 8



Experiment C begins like experiments A and B by an emission of a signal from the initial location of the observer at the point  $S_1$ . The signal begins propagation in the medium by Huygens' Principle as usual.

The signal spends some duration of propagation and meets the mirror A at the point  $A_2$ . The wave front of the signal forms sphere in the medium represented in the figure as the circle  $C_A$ (center  $S_1$ ). The observer takes location  $S_2$  at that moment relative to the medium-bound reference frame. The mirror B takes location at the point  $B_2$  at the same moment relative to the medium-bound reference frame.

The signal and the observer-bound mirrors continue their motion. The wave-front of the signal spreads further and meets the mirror B at the point  $B_3$ . The observer takes location  $S_3$ , and the mirror A takes location  $A_3$  at the same moment.

The signal reflected from the mirror A at the point  $A_2$  makes propagation in the medium as well as the original signal. It spreads in every direction and meets the observer at the point  $S_4$ . The signal forms sphere in the medium represented in the figure as the circle  $C_C$  (center  $A_2$ ).

The signal reflected from the mirror B at the point  $B_3$  makes propagation in the medium as well as the original signal. It spreads in every direction and meets the observer at the point  $S_4$ . The signal forms sphere in the medium represented in the figure as the circle  $C_D$  (center  $B_3$ ).

As a result, the observer detects both mirrored signals simultaneously again.

That happens because the signal spends the same duration to cover the same distance by any trajectory (see statement L). Experiment C has two pairs of equal elements. Those are circles  $C_A$  with the circle  $C_C$  and the circle  $C_B$  with the circle  $C_D$ .

Mutual location of their centers in the medium-bound reference frame depends on observer-to-mirror distance in the observer-bound reference frame and velocity of observer-to-medium relative motion in the medium-bound reference frame.

Duration if each circle (sphere) formation depends on the speed of the signal in the medium-bound reference frame and some moment when a signal makes interaction with the observer or a mirror in the medium-bound reference frame.

As a result, the observer ever meets the same observation

$$R_{CA} + R_{CC} = R_{CB} + R_{CD} \quad (4)$$

However (in general case),  $R_{CA} \neq R_{CC}$  and  $R_{CB} \neq R_{CD}$ . As soon as the observer changes a direction of his velocity, circles (spheres) represented in figure eight change their ratio of radiuses and adjust themselves so as the full duration of propagation of a signal in experiment C remains constant regardless direction of observer-to-medium relative motion (see statement L).

Those experiments (A, B, and C) depend on physical signal propagation in the medium-bound reference frame. Independence of that reference frame of any motion of observer's bound reference frame and any other observer-bound object gives that reference frame *the priority* in a description of any motion of the observer regarding that reference frame. That unique reference frame becomes the Wave Reference Frame (WRF). There is only one Wave Reference Frame in any given medium that supports propagation of waves (signals) because

*The existence of another Wave Reference Frame in the same medium is physically impossible.*  
(Statement M)

## VII. THE ELLIPTICAL LAW

Signal propagation shown in figure eight can be transformed to the observer-bound reference frame. Figure nine shows the result of that transformation.

Corresponding points with similar names have the same meaning in both figures. The equation (4) leads to some shape in the Wave Reference Frame (WRF) that follows the law represented by the equation.

*In case of a reference frame bound to a medium that supports propagation of a wave (a measuring signal), a moving transducer remains locations in two focuses of an ellipse at the moments of sending and receiving the measuring signal. Location of a body that mirrors the measuring signal and keeps the same distance from the transducer by a duration of a both-way propagation of a measuring signal forms an ellipse that depends on the transducer-to-medium uniform relative motion and a given distance between the transducer and the body mirroring the signal.*

(Statement N)

Statement 'N' is the *Elliptical Law of a Mirrored signal in a Moving Medium* or (ELM) for any measuring signal moving through any medium. (Zade Allan, 2016)

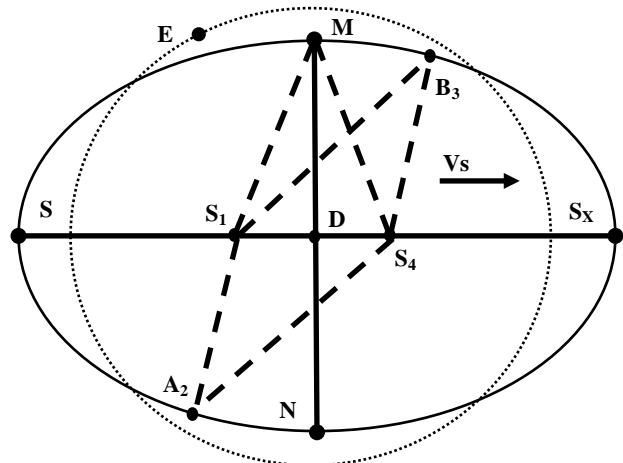

Fig. 9

Figure nine shows that ellipse  $SMS_xN$ . ELM explains the situation with an observer moving in a medium. The observer sends signals to a mirror and rotates mirror around the source of the signal. As a result, both signals (the initial signal and the reflected one) form an ellipse in the observer-bound reference frame. The same signals use way of propagation in the medium-bound reference frame shown in figure eight in case of a variable angle between the direction to a mirror and the direction of motion of the observer.

ELM gives the observer the same duration of any experiment with transmitted and reflected signals in any direction. Therefore,

*In case of constant speed of the observer in the wave reference frame and constant distance between the observer and the object mirroring the signal total duration of the experiment (that consist sending of initial signal and receiving a reflected signal) remains constant despite an angle between direction of observer's motion regarding the medium and the direction to the mirroring object.*

(Statement N)

ELM gives also a mind blowing experience to the observer that conducts such experiment. From the observer's point of view, his motion relative to a medium gives him a constant result that coincides with the result obtained in his motionless location in the medium.

In that case, the observer comprehends the experiment as an experiment in static medium and sees the distance between the observer and the mirror as a constant distance DE in any direction (fig. 9)

In other words, ELM makes the Mirroring Ellipse (ME) and the equivalent Mirroring Circle (MC) determined by the duration of a round-trip experiment indistinguishable from each other.

Is there any physical experiment that shows an application of ELM? That question has many positive answers. One of them comes from Norbert Feist's acoustic experiment.

### VIII. THE NORBERT FEIST EXPERIMENT

An ultrasonic range finder was mounted on a horizontally rotatable rail at fixed distance, S, to a reflector on the top of a car. The change of the distance reading, S, determined the two-way velocity of sound as a function of the car's velocity and direction. As a result of this experiment, the out and back velocity  $C_2$  was determined to be isotropic – as in the optical case of the Michelson-Morley experiment. Within the experimental error, the velocity was found to vary as  $C_2 = (C^2 - V^2)/C$ . (Feist Norbert, 2010).

A range finder sends a signal to an object and waits for a reflected signal. Distance between the range finder and the object determines as

$$S = \frac{1}{2}(VD) \tag{5}$$

Where V is the speed of sound in air and D is the duration of the measurement. The most critical parameter here is V because it should be measured in a lab before a range finder becomes operable. A rangefinder becomes useless without that value.

The next critical aspect is ratio 1/2. It comes from the human suggestion that both elements of measurements (the range finder and the object) remains motionless in the medium (air). That coincides with the old human illusion that only Earth surface can be used as the "right" reference frame. In that case, the measuring signal spends the same duration moving from the range finder to the object and from the object to the range finder. Therefore, the signal covers the distance twice. As a result, distance should be "recalculated" and reduced twice regarding data coming from the measurement (duration of the experiment).

Feist's experiment shows application of ELM in air. The range finder determines the circle E (fig. 9) regardless observer-to medium relative motion.

The experiment shows one more thing. The full duration of the experiment has inverse proportion to the speed of observer-to-medium motion. That is easily explainable by ELM (fig. 9)

There are two constants in the Feist's experiment. Those are sound-to-air speed and the given distance between the range finder and the mirroring object. The speed of observer-to-medium becomes variable.

In that case, distance  $S_1 - S_4$  depends on observer-to-medium relative motion. However, the speed of sound in the wave reference frame remains constant. As a result, wave-front of the signal uses different ways of propagation in the observer-bound reference frame and ratio of  $V/C$  becomes lesser. The figure ten shows that graphically.

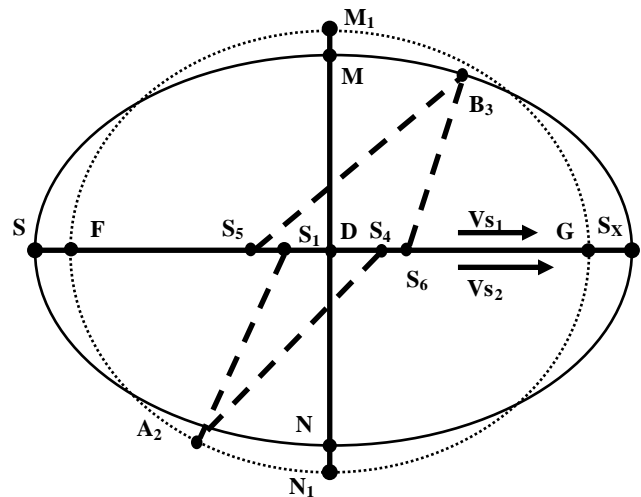

Fig. 10

Suppose an observer conducts two experiments A and B in acoustic environment. The

speed of observer-to-medium (observer-to-air) relative motion has greater value at the second experiment ( $V_{S_2} > V_{S_1}$ ).

Experiment A begins. The observer sends a signal from the point  $S_1$  in the wave reference frame that makes propagation in the medium (air) and meets the mirroring object (a reflector) at the point  $A_2$  in the wave reference frame (the medium-bound reference frame). The signal makes interaction with the reflector and makes backward propagation. The wave-front of the mirrored signal meets the observer at the point  $S_4$  of the wave reference frame. The experiment shows the duration  $D_A$  for that round-trip wave propagation. Rotation of the reflector around the observer does not change the duration of the round-trip experiment because of ELM that makes the Mirroring Ellipse  $N_1FM_1G$ . As a result, the duration remains constant ( $D_A$ ).

After the first experiment, the observer increases his speed of observer-to-medium relative motion to  $V_{S_2}$  and conducts another experiment. The observer sends a signal from the point  $S_5$  in the wave reference frame that makes propagation in the medium (air) and meets the mirroring object (a reflector) at the point  $B_3$  in the wave reference frame (the medium-bound reference frame). The signal makes interaction with the reflector and makes backward propagation. The wave-front of the mirrored signal meets the observer at the point  $S_6$  of the wave reference frame. The experiment shows the duration  $D_B$  for that round-trip wave propagation. Rotation of the reflector around the observer does not change the duration of the round-trip experiment because of ELM that makes the ellipse  $NSMS_x$ . As a result, the duration remains constant ( $D_B$ ).

The increased speed of the observer in the wave reference frame causes greater duration of experiment B because the wave front of the signal covers greater distance to reach the reflector and to come back to the observer. Distance  $S_5S_6$  becomes greater than  $S_1S_4$  because the speed of the signal in WRF (Wave Reference Frame) remains constant, but the speed of observer in the same reference frame increased. That also changes the ratio of the signal to observer speed of motion (equation 3) and the ellipse  $NSMS_x$  becomes more *elongated* than the ellipse  $N_1FM_1G$ .

Despite the increased speed, the observer sees the same ELM that shows *another constant value of duration* of the experiment in any direction ( $D_B$ ). In other words, the observer detects a given duration of a round-trip experiment at any given speed of the observer in the WRF.

Feist's equation

$$C_2 = (C^2 - V^2)/C \quad (6)$$

Shows also this.  $C_2 = C$  in case of  $V = 0$ . In other words,

*The speed of the signal measured by a round-trip experiment become identical in the observer-bound reference frame (OBRF) and the wave reference frame (WRF) only in case of motionless location of the observer in the wave reference frame.*

(Statement O)

Otherwise, "the speed of the signal" measured in the observer-bound reference frame become affected by the speed of observer-to-medium relative motion.

As mentioned above, *the Elliptical Law of a Mirrored signal in a Moving Medium* (ELM) works in any signal-medium combination because Huygens' Principle is applicable to all of them.

Misunderstanding of that law led to a huge problem in 20-th century physics.

## IX. THE MICHELSON-MORLEY EXPERIMENT

That experiment was "an attempt to detect the velocity of the Earth with respect to the hypothetical luminiferous ether, a medium in space proposed to carry light waves. First performed in Berlin in 1881 by the physicist A.A. Michelson, the test was later refined in 1887 by Michelson and E.W. Morley in the United States.

"The procedure depended on a Michelson interferometer, a sensitive optical device that compares *the optical path lengths for light moving in two mutually perpendicular directions*. It was reasoned that, if the speed of light were constant with respect to the proposed ether through which the Earth was moving, that motion could be detected by comparing the speed of light in the direction of the Earth's motion and the speed of light at right angles to the Earth's motion. *No difference was found*. This null result seriously discredited the ether theories and ultimately led to the proposal by Albert Einstein in 1905 that the speed of light is a universal constant." (Michelson-Morley experiment. (2008). Encyclopedia Britannica.)

The initial ideas of the experiment that belong to Michelson and rest on his speculations that a wave moving in a medium regarding an observer moving in the same medium *has a different duration in propagation in different directions*.

Michelson made calculations based on his speculations and built a physical device later to make physical measurements. The device *failed* to show anything close to his thoughts and falsified his point of view with all his predictions and reasoning for the experiment.

Despite that so-called Null result Michelson made two critical mistakes as a researcher. He never conducted the same test in other signal-medium combination. Physically, he had not any restriction to conduct the same experiment in air or water with acoustic signals.

Those experiments (like Feist experiment) show the same so-called “null result” for a constant speed of the observer in Wave Reference Frame (WRF).

The second grave mistake was this. The interferometer he used shows not any theoretically predicted data. In other words, a physical test destroyed the theory and Michelson’s speculations *immediately*. However, Michelson falls under illusion that his thoughts and calculations are correct and the physical device is “wrong” because the interferometer “refused” to show the result he expected.

That is a human mind related problem. Strictly speaking, that problem has not any relationship with science but affects science whenever a researcher puts *his human understanding higher that results of physical tests*. That contradicts the scientific method because that method requires physical tests as support for theories (not vice versa).

In case of Michelson’s experiment, he forgot that he uses a round-trip experiment instead of one-way experiment and the speed of the observer in the medium affects both signals in different ways. As a result, everything that increases the duration of forward propagation of an initial signal reduces the backward propagation of a reflected signal. Mathematics proposed to support his speculation makes support only for his illusion. As a result, physical test destroyed all illusions *immediately*.

Willingly or not, the Michelson interferometer confirmed ELM for light propagation with the best possible precision (as an optical device).

The device also confirms the constant speed of the observer in some reference frame that light uses for propagation (or in Light Wave Reference Frame, LWRF). In that case, ELM gives the observer no chance to detect observer-to-medium motion by a round-trip experiment.

To reach the result, the observer should split a *round-trip experiment for two one-way experiments* and determines the duration of those experiments *separately*. That idea exceeded the imagination of 19-th century researchers because “light has such a great speed of propagation that a one-way experiment is impossible.”

That is another one human-related point of view based on a technical possibility of 19-th century physical devices. Technological progress of the last century offers many devices which exceed the imagination of 19-th century researchers. Atomic clock is one of them.

## X. DE WITTE FINDINGS AND AURORA EFFECT

In 1991 Roland De Witte carried out an experiment in Brussels in which variations in the one-way speed of RF (radio frequency) waves through a coaxial cable were recorded over 178 days. The data from this experiment shows that De Witte had detected

absolute motion of the earth through space (Cahill Reginald, 2006)

In a 1991 research project within Belgacom, the Belgium telecommunications company, another (serendipitous) detection of absolute motion was performed. The study was undertaken by Roland De Witte. This organization had two sets of atomic clocks in two buildings in Brussels separated by 1.5 km and the research project was an investigation of the task of *synchronizing* these two clusters of atomic clocks. To that end 5MHz radio frequency (RF) signals were sent in both directions through two buried coaxial cables linking the two clusters. The atomic clocks were cesium beam atomic clocks, and there were three in each cluster: A1, A2 and A3 in one cluster, and B1, B2, and B3 at the other cluster. In that way the stability of the clocks could be established and monitored. (Cahill Reginald, 2006)

Synchronization of two or more clocks is not an easy task especially when they have high-frequency oscillators. That problem did not exist in ancient times because any pair of sundials were ever “synchronized” by the location of the sun in the sky.

The situation changed dramatically as soon as a man “invented” an escapement clock that uses an internal recurrent physical process *to emulate motion of the Sun in the sky*. Such clocks need not any relationship with the sun. As a result, the humankind faced a full-scale philosophical problem with the meaning of clock indication and “synchronous operation (indication)”.

In common understanding, a clock should have some “right” indication. That indication depends on human imagination about the location of the Sun in the sky regarding the location of the person (the observer). Moreover, such “indication” should “magically coincide” with the indication of a sundial at a given point of the earth surface.

That “right” indication should show the same “indication” of two or more clocks that coincides with the human expectation. Strictly speaking, that point of view *contradicts* the scientific method because a physical device operates by itself without any relationship with the human imagination or thoughts.

They usually make a solution of the problem of clock “synchronization” by sending a signal from one clock to another one. That method has one critical issue. *A signal spends some duration to reach another clock*. Therefore, any attempt to make synchronization that way faces the same problem of a definite duration of signal propagation between “clocks.”

They proposed an easy method of clock synchronization to make a solution of that problem. They claimed this. A signal spends equal duration going from the clock A to the clock B and from the clock B to the clock A because the signal is “very fast.” That method worked perfectly for mechanical clocks synchronized by acoustic or electromagnetic signals. However, precision

atomic clocks faced a serious problem. Figure eleven shows that problem graphically.

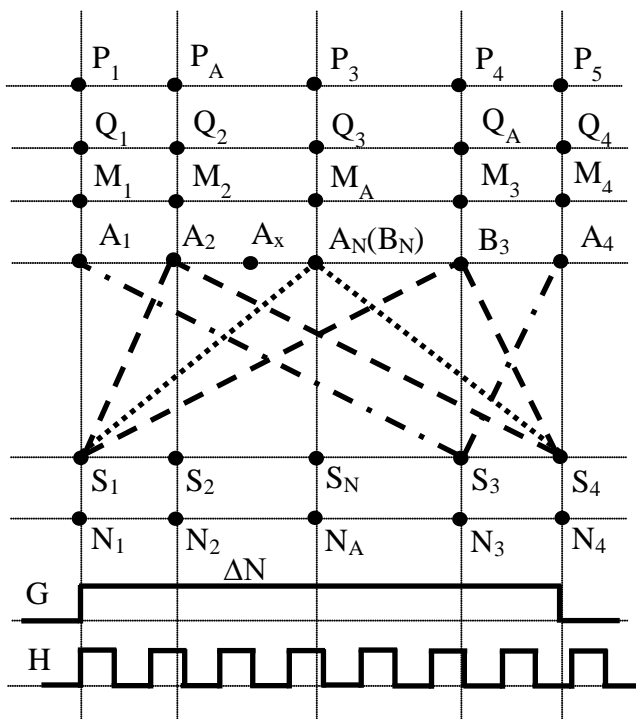

Fig. 11

Suppose an observer likes to make synchronization of two clocks which use high-frequency oscillators. The observer moves with one clock by the straight line  $S_1$ - $S_4$ . He sends the signal toward clock 'A' that moves in a straight line  $A_1$ - $A_4$  and keeps a constant distance from the observer  $L_A = S_1A_1$  (Fig. 8) in the observer-bound reference frame.

The signal meets the clock 'A' at the point  $A_2$  as explained above. That coincides with the line  $S_1A_2$  in both figures (shown in the fig. 11). The clock 'A' sends the signal back immediately. The signal moves in the medium as explained above and meets the observer at the point  $S_4$ . From the observer's point of view, the reflected signal covers the distance  $A_2S_4$  by a straight line. That is the line of propagation of the detectable signal. The full signal forms a sphere in the wave reference frame as explained above.

The observer also has no idea about the duration of forward and backward propagation of a signal. Instead of a detailed investigation of that problem he makes the easiest *postulate* that the duration of signal propagation in both directions has the same value.

As a result, he postulates this. The signal meets the clock A at the point  $A_N$  *simultaneously* with the moment when the observer-bound clock takes location at the point  $S_N$ . Backward propagation of the signal uses the same way, and the observer meets the reflected signal at the point  $S_4$  in the Wave Reference Frame.

That way of Signal-Based Synchronization (SBS) uses a human-made postulate of signal-to-observer propagation. The illusion of such "simultaneity" for a moving observer can be easily seen in any medium including water and air. However, 19-th century scientists paid no attention to them.

The next step of "synchronization" includes some "information to the clock 'A' that the clock should set "the right time" of  $M_A$  as soon as the clock detects the signal from the observer-bound clock.

At the next step of "synchronization" the clock 'A' sets the indication  $M_A$  and waits for the signal from the observer-based clock. That observer-based clock sends a signal toward the clock 'A' from the location  $S_1$  in the wave reference frame. The clock 'A' detects that signal at the point  $A_2$  sets indication  $M_A$  and sends a signal back to the observer-based clock. That signal meets the clock at the point  $S_4$ .

The observer thinks now this. Each clock has the same indication at any given moment. However, that is an *illusion* because the clock 'A' had location  $A_2$  at the moment when the signal reached the clock. From the observer's point of view, the clock 'A' had the location at the point  $A_N$  "because the signal spends the same duration in forward and backward motion." However, the signal "does not know" the observer's point of view and makes propagation by physical interaction with the medium *instead of physical interaction with the observer's mind*.

As a result, the clock 'A' has indication  $P_A$  (Fig. 11, band 'P') shifted to the value  $\Delta N = N_A - N_2$  ( $P_A = N_A - \Delta N = N_2$ ) according to indications of the observer-bound clock.

However, the observer's illusion persists because every round-trip experiment gives the same difference between indications of the clock 'A' and the observer-bound clock.

Suppose now this. The observer likes to conduct synchronization with another clock 'B' equidistant from the observer and stays on the same straight line that connects clocks A, B and the observer (Fig. 8, line  $A_1S_1B_1$ ). The observer uses the same way of signal-based synchronization (SBS).

The observer sends the signal from the point  $S_1$  (Fig 11). The signal meets the clock 'B' at the point  $B_3$  in the wave reference frame. The clock detects the signal and sends the signal back to the observer. The mirrored or retransmitted signal meets the observer at the point  $S_4$  in the wave reference frame.

The next step of "synchronization" includes some "information to the clock 'B' that the clock should set "the right time" of  $M_A$  as soon as the clock detects the signal from the observer-bound clock.

At the next step of "synchronization" the clock 'B' sets the indication  $M_A$  and waits for the signal from the observer-based clock. That observer-based clock

sends a signal toward the clock 'B' from the location  $S_1$  in the wave reference frame. The clock 'B' detects that signal at the point  $B_3$  sets indication  $M_A$  and sends a signal back to the observer-based clock. That signal meets the clock at the point  $S_4$ .

The observer thinks now this. Two clocks have the same indication at any given moment. However, that is an illusion because the clock 'B' had location  $B_3$  at the moment when the signal reached the clock. From the observer's point of view, the clock 'B' had the location at the point  $B_N$  (that coincides with the point  $A_N$  in the fig, 11) "because the signal spends the same duration in forward and backward motion." However, the signal "does not know" the observer's point of view and makes propagation by physical interaction with the medium *instead of physical interaction with the observer's mind*.

As a result, the clock 'B' has indication  $Q_A$  (Fig. 11, band 'Q') shifted to the value  $N_3 - N_A$  according to indications of the observer-bound clock.

However, the full duration of the experiment with the clock 'B' coincides with the full duration of the experiment with the clock 'A.' That *numerical coincidence* puts the observer under the illusion that both experiments are identical and all three clocks have the same indications *simultaneously*.

Everything looks fine until the observer tries to make synchronization of clocks in backward direction sending the signal from the clock 'A' to the observer-bound clock.

At the previous step of signal-based synchronization the clock 'A' possessed the indication  $P = N_A - \Delta P = N_A - (N_A - N_2)$  as explained above. The clock 'A' sends the signal to the observer-based clock from the point  $A_2$  of the wave reference frame. The signal meets the observer at the point  $S_4$ . The duration of signal propagation by  $A_2S_4$  has the same value ever because of the equidistant location of clocks 'A' from the observer in the observer-based reference frame and constant speed of propagation of the signal in the wave reference frame.

The observer detects the signal at the point  $S_4$ . After that, the observer analyses information about the indication of the clock 'A' at the moment of signal emission. The observer expects the value  $M_A$  equal to  $N_A$  that he was set *artificially* in the previous circle of synchronization. To his surprise, he takes  $P_A = N_A - \Delta N = N_2$ .

The presence of stable deviation  $\Delta N$  put the observer to nonplus. From his point of view, two clocks lost their synchronous operation. However, another attempt of *forward synchronization* shows a perfectly synchronous operation of both clocks.

The observer thinks for some time and tries the experiment of backward synchronization again. To his surprise deviation  $\Delta N$  changes its value and shows another stable value. The observer cannot explain such "strange" behaviors of clocks from his point of view

based on his imagination about observer-bound reference frame.

However, the explanation is easy in the wave reference frame. As soon as the observer-bound inertial reference frame (IRF) change its *orientation* regarding the wave reference frame (WRF), ELM changes the duration of one-way propagation of the signal. As a result, full duration of a round-trip propagation of the signal between clocks keeps the same constant value, but each one-way propagation changes its value.

In that case, the observer tries to make a comparison of *his imagination and a physical process*. From the observer's point of view, the signal emitted from him at the point  $S_1$  meets the clock 'A' at the point  $A_N$  because that point coincides the location of the observer at the point  $S_N$ . As a result,

*Deviation of the physical location of a remotely located clock from image location of the same clock based on the observer's point of view causes physical deviation of signal based synchronization of two clocks.*

(Statement P)

In other words, a physical experiment of signal based synchronization shows the mistake of observer's imagination, and value of  $\Delta N$  appears as the difference between the physical location of the clock 'A' and image location of the same clock from the observer's point of view during the experiment. That is the measurement of "illusion in hand."

Deviation  $\Delta N$  has zero value in one condition for an observer moving in wave reference frame. It happens when the observer orientates the line  $A_1B_1$  perpendicular the direction of his motion in WRF (Fig. 7). It is only a particular case. In general case, that deviation persists and becomes observable in every experiment in any signal-medium combination.

The numerical result of the experiment depends on a few aspects:

- The speed of observer-to-medium relative motion
- The speed of the signal in the WRF
- The orientation of inertial reference frame (IRF) (observer bound reference frame) in wave reference frame (WRF).

The last aspect shows significant influence in case of rotation of the observer bound reference frame. In that case, deviation  $\Delta N$  depends on the orientation of the observer-bound reference frame regarding direction of motion of the observer in WRF.

Therefore, deviation  $\Delta N$  should show a solid circle of changes from the maximal to the minimal value that coincides with the duration of the full revolution of the observer bound reference frame in WRF.

Here and later deviation  $\Delta N$  referred as Mutual Signal Based Synchronization Deviation (MSBSD) or *Aurora Effect (AE)*. In case of an Earth-bound observer, that phenomenon leads to detection of *sidereal rotation of the Earth* as a result of any attempt of *backward*

synchronization of two or more atomic clock clusters. That is *White Aurora Effect* that shows the phenomenon immediately.

Sidereal period is the time required for a celestial body within the solar system to complete one revolution with respect to the fixed stars—i.e., as observed from some fixed point outside the system. (Sidereal period. (2008). Encyclopedia Britannica.)

There is one more observable phenomenon in case of forward synchronization. Suppose the observer conducts synchronization of an observer-bound clock and the clock 'A' as described above.

The observer starts observation of both clocks indications after their signal-based synchronization. To his surprise those clocks show some strange phenomenon. Both clocks belong to the observer-bound reference frame that changes orientation regarding the direction of observer-to-medium relative motion because of rotation of the Earth.

As a result, duration of one-way propagation of signals between the observer-bound clock and the clock 'A' changes ratio of a duration of forward and backward propagation. From the observer's point of view, that motion changes a location of the clock 'A' regarding the observer-bound clock from  $A_2$  to  $B_3$  (Fig. 11).

Therefore, rotation of the Earth causes slow deviation of indication of previously "synchronized" clocks. That deviation has zero value immediately after clock "synchronization" and changes slowly during Sidereal Period. In general case, each Sidereal Period gives two zero values, the maximum, and the minimum values. The appearance of those values to the observer during Sidereal Period depends on the orientation of the straight line connecting two clocks regarding the direction of their motion in WRF.

For example, the clock 'A' has location  $A_x$  (Fig. 11) at the moment of "synchronization." In that case, the observer sees "synchronous indication" of both clocks only in that orientation. However, the orientation is not static because of rotation of the Earth. That process slowly changes the orientation of two clocks (regarding the direction of their motion in WRF). That coincides with motion of the point A in figure eleven. As long as the point A moves from the point  $A_2$  to  $B_3$  the observer sees that the indication of the clock 'A' looks like "going faster and faster." The clock 'A' goes before the observer-bound clock more and more (between points  $A_x$  and  $B_3$ ) until it reaches the maximal positive deviation at the point  $B_3$ .

As long as the clock 'A' moves from the point  $B_3$  to the point  $A_2$  the observer sees that the indication of the clock 'A' looks like "going slower and slower." The clock 'A' goes after the observer-bound clock more and more (between points  $A_x$  and  $A_2$ ) until it reaches the maximal negative deviation at the point  $A_2$ .

Positive deviation mentioned above means *Blue Aurora Effect*; negative one means *Red Aurora Effect*.

Suppose now this. There is one more observer (the observer 'B') with two more clocks (local and remotely located one) with another orientation regarding the direction of motion of his IRF in WRF. The observer 'B' makes signal-based "synchronization" a bit later (or sooner) than the observer 'A.' It gives him another location of a remotely located clock (for example, location  $A_N$ , Fig. 11) regarding the orientation of *his IRF in WRF*. In that case, he detects "synchronous" indications of his clocks when the observer 'A' sees some *deviation* of indication of a remotely located clock. That coincides some distance  $A_x - A_N$  in figure eleven.

That situation means "synchronous" indication of one pair of signal-based synchronized clocks and some deviation from "synchronous indication" of another pair of signal-based synchronized clocks. That difference means *Green Aurora Effect*.

Strictly speaking,

*Aurora Effect eliminates any possibility to see the continuously synchronous operation of two or more clocks after signal-based synchronization (SBS).*

(Statement Q)

Moreover,

*Aurora Effect gives independent prove of rotation of the planet without optical observation of the sky.*

(Statement R)

There is one more critical aspect here. An observer should have an oscillator with enough frequency to detect Aurora Effect (MSBSD). In case of a low-frequency oscillator (Fig. 11, band G) duration of one oscillation is higher than entire process of signal propagation in both directions (duration of a round-trip experiment).

In case of a high-frequency oscillator (Fig. 11, band H) the observer detects the phenomena because the signal spends the duration of two oscillations in forward motion ( $N_1N_2$ ) and duration of five oscillations in backward motion ( $N_2N_4$ ).

Therefore, *an oscillator can be recognized under given circumstances as a high-frequency one if a physical measurement device based on that oscillator becomes able to detect Aurora Effect.*

That phenomenon with critical importance for physics was detected by De Witte because he fulfills *essential requirements* of the experiment mentioned above. He had high-frequency oscillators and enough distance to send signals between measurement devices.

## XI. THE EINSTEIN'S ILLUSIONS

Einstein, Albert was born March 14, 1879, Ulm, Württemberg, Ger. died April 18, 1955, Princeton, N.J., U.S. German-born physicist who developed the special and general theories of relativity and won the Nobel Prize for Physics in 1921 for his explanation of the

photoelectric effect. Einstein is generally considered the most influential physicist of the 20th century. (Einstein, Albert. (2008). Encyclopedia Britannica)

The most critical word of the citation given above is *Influence*. Influence (by Merriam-Webster Dictionary) can be recognized as

1. an ethereal fluid held to flow from the stars and to affect the actions of humans
2. an emanation of spiritual or moral force
3. the act or power of producing an effect without apparent exertion of force or direct exercise of command

The second definition is the best one for application to a result of scientist's actions or research. Suppose now this. There are two persons A and B. The person A spent all his life in Amazon jungles. The person B served NASA all his life.

They meet each other on the Bermuda Islands and share their life experience with each other. The person B understands everything that the person A tells him because he has seen a lot of satellite images of Amazon jungles. However, person A does not understand the person B because categories shown by that person like rocketry, thrust, jet engines, space navigation, Apollo Program and many others have no meaning for the person A.

That happens because the person B uses categories which stay beyond the Comprehension Horizon (CH) of the person A. As a result, the person A cannot comprehend any of them because he is unable to make any link between categories known for him and a category shown by the person B.

Strictly speaking, the humankind face the Comprehension Horizon Problem (CHP) throw-out all history of the civilization. Every idea that can be recognized as a meaningful should stay inside the Comprehension Horizon. Everything coming from the outside of the Comprehension Horizon looks like a weird idea and usually rejected by the general population.

Science has some relationship with that problem. They usually tell this. A researcher should explain his point of view in "their language" because other categories are not usually understandable for them. That way leads to serious distortion of basic categories in the mind of other people who like to understand something but *do not like to build new categories in their mind*.

The result of such situation appears as some influential people give an explanation of a problem in categories familiar to people looking for such explanation. Therefore, Einstein gave some explanations of "unexplainable experiments" in categories acceptable for scientists of 19-th century.

In Maxwell's time, a mechanistic view of the universe held sway. Sound was interpreted as an undulatory motion of the air, while light and other electromagnetic waves were regarded as undulatory

motions of an intangible medium called ether. The question arose as to whether the velocity of light measured by an observer moving relative to ether would be affected by his motion. Albert Abraham Michelson and Edward W. Morley of the United States had demonstrated in 1887 that light in a vacuum on Earth travels at a constant speed which is independent of the direction of the light relative to the direction of the Earth's motion through the ether. (Electromagnetism. (2008). Encyclopedia Britannica.)

As mentioned above, later experiments in other signal-medium combinations show the same so-called "null" results because of ELM *unknown* in 19-th and 20-th centuries. Einstein used the same mechanistic view of the universe to create his theory widely known as the theory of Relativity. He was unable to explain some critical aspects of physical phenomena like constant speed of light in the observer-bound reference frame in case of the constant speed of that reference frame in wave reference frame and produced a lot of postulates to avoid questions to his explanations. He started his speculations with "the basic and the most certain aspects known for the people of the 19-th century."

"Let us take a system of co-ordinates in which the equations of Newtonian mechanics hold good. In order to render our presentation more precise and to distinguish this system of co-ordinates verbally from others which will be introduced hereafter, we call it the "stationary system."

"If a *material point* is at rest relatively to this system of co-ordinates, its position can be defined relatively thereto by the employment of rigid standards of measurement and the methods of Euclidean geometry, and can be expressed in Cartesian co-ordinates.

"If we wish to describe the motion of a material point, we give the values of its co-ordinates as functions of the time." (Einstein Albert, 1923)

In other words, Einstein associates the observer a-priory with some coordinate system and try to describe motion of other things (including waves) in that reference frame.

Einstein as a man grown in 19-th century shared scientific paradigm of that time. That paradigm requires a mathematical description of motion in Inertial Reference Frames proposed by Newton to his explanation of celestial mechanics based on the gravitational interaction between all celestial bodies.

In other words, Einstein thinks in categories of inertial reference frames associated with physical bodies and denies any further research in that area. Therefore, the idea that a signal can be recognized as a reference frame (WRF, as explained above) looks weird for him as well as for any other person from 19-th century.

From their point of view, there is the only one possibility to describe motion. That is an inertial reference frame like shown in figures two and three. That



inertial reference frame (IRF) has one particular aspect mentioned above. A physical interaction of elements inside IRF keeps the same duration of experiment with a moving body (a bullet) in any direction. That duration keeps the same value for all possible IRF as explained above (see section five)

That phenomenon has an easy explanation. In case of gun-bullet experiment mentioned above, a gun and a bullet exist before the experiment, during acceleration, and after acceleration when all elements come back again to inertial elements in reference to their reciprocal motion.

The notion of acceleration is a critical one in the understanding of IRF. To make (or create) motion in IRF *an inertial object* should apply some force to *another inertial object*. That force according to the second law of Newton produces an *acceleration* of both bodies in inverse proportion to their masses. As a result, a body with lesser mass has greater acceleration. For the same reason of practical application, a bullet is *ever lighter than a gun*.

Unlike object-to-object interaction, object-to-wave and wave-to-wave interaction have a significant difference:

- A wave does not exist before an experiment. Therefore, motion (or the speed) of a wave before the experiment does not exist also.
- A wave needs not any application of force to make acceleration after creation to reach a constant speed in a medium.
- A wave uses Wave Reference Frame to make propagation in a medium regardless observer-to-medium relative motion.

Misunderstanding of those critical differences of motion of an object and a wave led to great illusions of 19-th century physics. They understand and explain the propagation of light like motion of a bullet. From their point of view, an observer “shoots” light in some direction like a gunner firing a bullet. As a result, observer-to-light speed of relative motion becomes the same in every direction as well as the speed of bullet-to-gun relative motion in a gunman-bound reference frame. Figure three shows that point of view.

Such speculations led to the following point of view coming from Einstein.

*“We have not defined a common “time” for A and B, for the latter cannot be defined at all unless we establish by definition that the “time” required by light to travel from A to B equals the “time” it requires to travel from B to A.”*

(Statement EA)(Einstein Albert, 1923)

That point of view created an illusion in the Einstein’s mind that:

$$T_{ABA} = T_{AB} + T_{BA} \quad (7)$$

$$T_{AB} = T_{BA} = \frac{1}{2}T_{ABA} \quad (8)$$

The transformation from (7) to (8) looks really “logical” to Einstein because those equations work perfectly in an Inertial Reference Frame. However, light is a wave. Einstein knew that but applied the law of Inertial Reference Frame to Wave Reference Frame (that was unknown to him).

Strictly speaking, Einstein could not think in categories of Wave Reference Frame as a man grown in 19-th century when ideas of Newton were in full power. Einstein saw his task to make a *mathematical explanation* of a particular experiment (Michelson-Morley experiment) in Theoretical Framework proposed by Newton. Quotations from his famous work mentioned above show that problem of his point of view.

As a result, the following transformation was unreachable for his mind.

$$T_{ABA} = T_{AB} + T_{BA} = (T_{AX} + N) + (T_{BX} - N) \quad (9)$$

That happened because Theoretical Framework used in 19-th century required only Inertial Reference Frames in a description of any motion. Moreover, equation (9) gives not any possibility of a mathematical solution. Therefore, Einstein proposed a famous postulate (Statement EA).

Einstein faced here the same problem of physical experiments. Physical tests of propagation of signals in a moving medium contradict statement EA. Strictly speaking, Einstein could make those tests by himself. However, he denied any activity in experimental physics (or in a lab).

Moreover, “Einstein could apply directly to the Eidgenössische Polytechnische Schule (“Swiss Federal Polytechnic School”; in 1911, following expansion in 1909 to full university status, it was renamed the Eidgenössische Technische Hochschule, or “Swiss Federal Institute of Technology”) in Zürich without the equivalent of a high school diploma if he passed its stiff entrance examinations. His marks showed that he excelled in mathematics and physics, but he failed at French, chemistry, and biology. Because of his *exceptional math scores*, he was allowed into the polytechnic on the condition that he first finish his formal schooling.”(Einstein, Albert. (2008). Encyclopedia Britannica).

In other words, his “*exceptional math scores*” formed his point of view on mathematics that mathematical calculations *could save him from any mistake that can appear by another way of thoughts*. Such illusion became the heaviest one in 20-th century physics and turned many researchers from full-scale experiments, thoughts and philosophy to simple “calculations.” However,

*The numerical coincidence of any given values means not a direct prove of researcher’s point of view*

until the researcher gives a step-by-step explanation of a physical process and physical interaction of a measurement device and measuring value.

(Statement S)

Despite Statement 'S', Einstein try to explain the so-called null result of Michelson interferometer by pure thought experiments and pure mathematical calculations. That happened because he had not permission to enter a lab because Einstein was not a successful scientist after graduation.

"After graduation in 1900, Einstein faced one of the greatest crises in his life. Because he studied advanced subjects on his own, he often cut classes; this earned him the animosity of some professors, especially Heinrich Weber. Unfortunately, Einstein asked Weber for a letter of recommendation. Einstein was subsequently turned down for every academic position that he applied to." (Einstein, Albert. (2008). Encyclopedia Britannica)

The result of such situation appeared almost immediately. "In 1902 Einstein reached perhaps the lowest point in his life. He could not marry Maric and support a family without a job, and his father's business went bankrupt. Desperate and unemployed, Einstein took lowly jobs tutoring children, but he was fired from even these jobs.

"The turning point came later that year, when the father of his lifelong friend, Marcel Grossman, was able to recommend him for a position as a clerk in *the Swiss patent office in Bern*. About then Einstein's father became seriously ill and, just before he died, gave his blessing for his son to marry Maric. For years, Einstein would experience enormous sadness remembering that his father had died thinking him a failure." (Einstein, Albert. (2008). Encyclopedia Britannica).

"With a small but steady income for the first time, Einstein felt confident enough to marry Maric, which he did on Jan. 6, 1903. Their children, Hans Albert and Eduard, were born in Bern in 1904 and 1910, respectively. In hindsight, Einstein's job at the patent office was a blessing. He would quickly finish analyzing patent applications, leaving him time to *daydream about the vision that had obsessed him since he was 16: What will happen if you race alongside a light beam?* While at the polytechnic school he had studied Maxwell's equations, which describe the nature of light, and discovered a fact unknown to James Clerk Maxwell himself—namely, that the speed of light remained the same no matter how fast one moved. This violated Newton's laws of motion, however, because there is no absolute velocity in Isaac Newton's theory. This insight led Einstein to formulate the principle of relativity: "the speed of light is a constant in any inertial frame (constantly moving frame).

"During 1905, often called Einstein's "miracle year," he published four papers in the *Annalen der Physik*" (Einstein, Albert. (2008). Encyclopedia Britannica).

The quotation given above explains the core illusion of 19-th century physics. "The speed of light remained the same no matter how fast one moved," that is correct for any signal in any medium as explained above. However, that law is applicable only in Wave Reference Frame instead of Inertial Reference Frame (or an observer-bound reference frame).

The situation when Einstein mistakes a Wave Reference Frame with an Inertial Reference Frame caused the greatest problem and controversy in 20-th century science.

"This violated Newton's laws of motion, however, because there is no absolute velocity in Isaac Newton's theory." That statement is incorrect. Newton's laws of motion are applicable only in an Inertial Reference Frame (IRF). An observer should apply some *force* to change any motion in IRF. Otherwise, a Reference Frame cannot be called or used as *inertial one*.

As mentioned above, a signal has no "acceleration" by any force in a WRF. Therefore, that frame is entirely different from any IRF, and Newton's laws of motion have no meaning in that RF.

"(Einstein) discovered a fact unknown to James Clerk Maxwell himself—namely, that the speed of light remained the same no matter how fast one moved". That is also incorrect because Maxwell's equations describe propagation of EM radiation. They have not any "connection" to a Reference Frame in which that speed does appear.

From Einstein's point of view, that should be only the Inertial Reference frame bound to the observer. However, there is nothing in experimental physics that shows that way of light propagation. That mistake led him to the incorrect formulation of his "principle of relativity" mentioned above that "the speed of light is a constant in any inertial frame (constantly moving frame)." The right statement is this.

*The duration of a round-trip experiment with a signal keeps constant value in the observer-bound Inertial Reference Frame as long as an observer keeps a constant speed in the Wave Reference Frame regardless direction of signal propagation in the observer-bound Inertial Reference Frame.*

(Statement T)

That is a transformation of ELM (Statement N) for an observer with a constant speed of motion in the Wave Reference Frame that makes measurements by a round-trip experiment.

In other words, all postulates of Einstein were understandable for physicists grew in 19-th century. As a result, no one of them put any physical counter arguments against them, and newer conducted Michelson type experiments in a different medium until *Norbert Feist made them himself in 21-th century*.

Is it possible to make counterarguments to basic postulates of relativity by a physical device that

makes physical measurements instead of speculations? Is it possible to make a universal device that changes the human mind forever and give independent physical prove for all experiments and phenomena mentioned above? Such device was proposed in the form of a Signal Medium Motion Measurement Apparatus or SMA (International Patent Application WO/2015/040505).

## XII. THE SIGNAL MEDIUM MOTION MEASUREMENT APPARATUS

The apparatus uses no human assumptions of any kind. In other words, it is a pure apparatus that makes operation by itself regardless any illusion that a human being likes to put in a measurement device.

The core of the apparatus comprises an Oscillating Device (OD) and a Counting Device (CD). The oscillating device keeps internal recurrent physical process that makes oscillations. Oscillations make pulses. The counting device counts pulses coming from the oscillating device. All measurements appear as a number of oscillations counted by the counting device. There is no room for any illusion inside that interaction of the devices. There are also two more devices for emitting (ED) and detecting (DD) a signal. Those devices make physical interaction with the Measurement Channel (MC).

To make experiment possible, an observer should use at least two apparatuses. They form a Linear Detector that way. The apparatuses use one more device called Distance Measurement Device (DMD) that give the apparatuses information about the distance that separates them in the observer bound Inertial Reference Frame. That distance can be changed by one apparatus that moves back and forth regarding the other apparatus. The apparatuses have a link in the form of a communication channel (CC).

To make apparatuses ready to work the observer should make synchronization of Counting Devices of the apparatuses that depend on *the purpose of the experiment*. If the observer likes to make measurements of IRF motion in WRF, he uses the Local Synchronization and Remote Operation Method (LSROM).

In that case, the apparatus B goes next to the apparatus A. The apparatus A picks up any suitable value of further indication (N) of its CD and sends that indication to the apparatus B by the Communication Channel (CC). The apparatus B sets that value on its CD and waits for the next signal from the apparatus A by the Measurement Channel (MC). As soon as the indication of the Counting Device of the apparatus A reaches the value N the apparatus emits a signal by the Emitting Device (ED). The signal goes via the Measurement Channel (MC) to the apparatus B. The apparatus B detects the signal by its Detecting Device and connects its Oscillating Device to the Counting Device. In that

case, an indication of both Counting Devices become equal to each other because of zero distance between the apparatuses during the procedure of Local Synchronization.

After Local Synchronization, every oscillation coming from the Oscillating Device of the apparatus changes the indication of the Counting Device of the same apparatus. That physical process is identical in both apparatuses. Therefore, the indication of the Counting Device of a given apparatus changes *simultaneously* with the indication of the other apparatus. That means *physical simultaneity* because a signal spends zero duration to cover zero distance in any medium. Therefore, Counting Devices of the apparatuses show the identical indication ever and change them simultaneously with every pulse coming from Oscillating Devices.

After Local Synchronization, the observer separates those apparatuses by a given distance, and they become able to determine a duration of any physical process including motion of anything between them by the right measurement based on physical simultaneity. As a result, the full method that includes synchronization and operation becomes the Local Synchronization and Remote Operation Method (LSROM). Therefore,

*Physical simultaneity gives a possibility to conduct a one-way experiment in any medium.*

(Statement U)

The Comprehension Horizon of 19-th century physicists blocks their attempts to conduct one-way experiments. They used the equation (1) with the one clock and electrical signal coming from the start and the finish points of a moving thing. Actually, the speed of an electrical pulse in a wire many times greater than the speed of other inertial objects and experiments with one clock and two wires give good results for any inertial objects and physical signals except electromagnetic signals (EMS).

In case of EMS, duration of propagation of a signal in a medium (vacuum) becomes equal to the duration of propagation of the same signal in a wire. Figure twelve shows that problem.

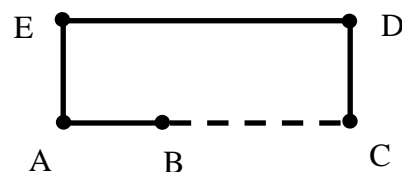

Fig. 12

Suppose an observer likes to measure a duration of light propagation between points B and C. The 19-th century observer puts a clock at the point A and connects a light emitter B to a clock A and light detector C to the same clock by a wire CDEA.

The experiment begins. The observer sends a signal to the light emitter B from the point A and waits the signal coming back by the wire CDEA. To his surprise, the duration of that experiment becomes constant despite variable distance BC and constant distance AC. In that case, the observer should make a controversial decision that a beam of light covers *any distance by the same "time"* because the experiment shows constant duration regardless distance BC.

The 21-th century researcher understands this. The experiment involves propagation of the signal by round path ABCDE. Each element of that path affects the full duration. *Each element of that path follows ELM.* Therefore, full duration of the experiment shows a constant value regardless of any combination of those elements or their orientation.

To make pure measurements the observer should have two measurements devices that show the same values of duration during the experiment simultaneously at the points B and C. That task was impossible in 19-th century. However, further engineering and technological progress offer the possible solution of that problem.

Two SMAs mentioned above after procedure of Local Synchronization show identical readings and change them simultaneously with every pulse of the Oscillating Device. Therefore, the observer can leave one apparatus at a given place and set another one at a remote location. An indication of counting devices of those apparatuses keeps *physical simultaneity* regardless any distance that separates the apparatuses.

Therefore, the observer has two measurement devices with ever equal indications of counting devices separated by a given distance. That is the best condition to make measurements of one-way signal propagation. In other words, Local Synchronization and Remote Operation Method (LSROM) lead to one-way experiments in *any medium*. In case of LSROM, the apparatuses need not any information about medium or its physical condition. They make physical measurements and give the result to the observer. That destroys a 19-sentury point of view that "a device" can be synchronized only by a signal (signal-based synchronization, SBS).

In case of the experiment with light, apparatus B moves away from the apparatus A to any distance that the observer likes to use in the experiment. After that, the apparatus A sends a signal to the apparatus B and registers the indication of the counting device of the apparatus A ( $CD_A$ ).

The apparatus B waits for the signal and registers the upcoming signal by the reading of the counting device of the apparatus B ( $CD_B$ ). The full duration of the experiment can be determined now by difference if indications of their counting devices at the moment of sending the signal from one apparatus and receiving the same signal by the other apparatus. The

full duration of one-way experiment becomes calculable by the following equation.

$$D_{AB} = D_F = CD_A - CD_B \quad (10)$$

Where  $D_{AB}$  is the duration of the one-way experiment (forward propagation,  $D_F$ ) in oscillations of the oscillating devices of the apparatuses,  $CD_A$  and  $CD_B$  are indications of counting devices of the apparatus A and B accordingly.

The same way of measurements is applicable for any signal-medium combination. As a result, the patent application describes all experiments from the same point of view without *any exception*.

At the next step of the experiment, the apparatus B sends the signal back to the apparatus A. The apparatuses make the same measurement described above and determined the full duration of the signal propagation in another direction. From the Inertial Reference Frame bound observer's point of view, those are experiments of forward and backward signal propagation in his reference frame (IRF).

$$D_{BA} = D_B = CD_B - CD_A \quad (11)$$

Comparison of duration of the signal propagation in both directions gives the observer enough information to determine his motion in WRF. As long as the duration of propagation of the signal remains the same value in both directions despite orientation of the apparatuses, the Observer-Bound Inertial Reference Frame (OBIRF) remains motionless location in Wave Reference Frame (WRF). Otherwise, the observer detects and determines motion of IRF in WRF *by any calculation he likes*. In that case, the observer determines velocity of his motion in WRF.

"To determine a magnitude of the vector, SMA makes easy calculations. It determines two velocities (of forward and backward motion) of the measuring signal  $V_F$  (velocity of forward motion) and  $V_B$  velocity of backward motion along the straight line connecting the apparatuses (AB-line) by the following way.

$$V_F = \frac{L}{D_F} \quad (12)$$

$$V_B = \frac{L}{D_B} \quad (13)$$

"There, L is the length of the measurement line (AB distance),  $D_F$  is a duration of forward motion of the measuring signal,  $D_B$  is a duration of backward motion of the measuring signal.

"By basic equations of the velocities, there are two elements in each case. Those are the speed of signal-to-medium motion (E, or Electromagnetic Signal Space Speed) and the speed of SMA-to-medium motion (observer-to-medium motion) (V)

$$V_F = E + V \quad (14)$$

$$V_B = E - V \quad (15)$$

“Therefore,

$$V_F = E + V ; V = V_F - E ; V_B = E - (V_F - E) = 2E - V_F ; 2E = V_F + V_B ; \tag{16}$$

$$E = (V_F + V_B)/2 \tag{17}$$

“The same way gives the following value of V.

$$V_B = E - V ; E = V_B + V ; V_F = (V_B + V) + V = 2V + V_B ; 2V = V_F - V_B ; \tag{18}$$

$$V = (V_F - V_B)/2 \tag{19}$$

“Equation (17) shows this. The speed of signal-to-medium motion (E) equals to the speed of observer-to-signal motion (C) only in one case then  $V_F = V_B$ . That means equal duration of forward and backward motion of a measuring signal ( $D_F = D_B$ ) *in every direction* and coincides with the Einstein’s postulate mentioned above. However, that is only a particular case. In general case,  $D_F \neq D_B$  and  $V_F \neq V_B$ , and the same postulate becomes *wrong*.”(Zade Allan, 2016)

SMA’s confirm their experimental data of motion of IRF in WRF by some consequent experiments with various distances between apparatuses. Variation of distance L leads to increasing (or decreasing) duration of signal propagation on every element of the experiment. However, the result of measurements remains constant because all elements affected equally *by the same motion of IRF in WRF* that SMA determines. That physical motion cannot be affected by measurements of SMA.

There is one more application of SMA that shows the Wave Reference Frame of Light (LWRF) or the Ghost Reference Frame (GRF) that makes distortion of the human mind and affects badly human philosophy throughout the 20-th century.

### XIII. THE TRIDENT EXPERIMENT

This experiment shows the same law of signal propagation for various signals in various signal-medium combinations. Figure thirteen shows that experiment graphically.

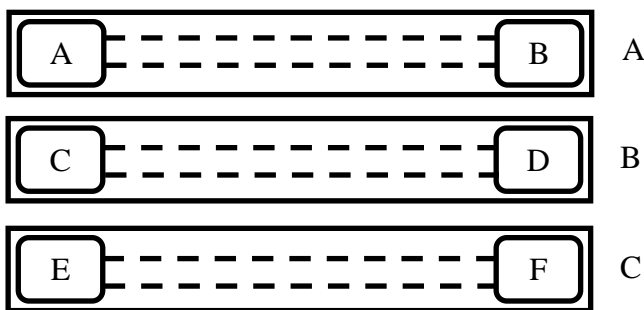

Fig. 13

There are three containers with a couple of SMA’s in each of them. All SMA’s synchronized by LSROM and keep synchronous changes of their CD

during the experiment. All containers isolated from any influence from the outside.

The container A has water as the substance surrounding the SMA A and the SMA B. Those apparatuses use acoustic transducers to send and receive acoustic signals.

The container B has water as the substance surrounding the SMA C and the SMA D. Those apparatuses use optical emitters to send signals and optical detectors to detect optical signals.

The container C has the vacuum as the substance surrounding the SMA E and the SMA F. Those apparatuses use optical emitters to send signals and optical detectors to detect optical signals.

The experiment begins. Each apparatus sends a signal to another apparatus and receives a signal coming from another apparatus as explained above.

Apparatuses A and B detect their zero motion regarding a given WRF (water) because the duration of propagation of the forward signal equals to the duration of propagation of the backward signal. Therefore, apparatuses keep motionless location in the given medium (water). The full duration of the experiment coincides with other experiments with reflected acoustic signals in water measured by other devices.

Apparatuses C and D detect some motion regarding WRF because the duration of the forward signal becomes unequal to the duration of the backward signal. The full duration of the experiment coincides with other experiments with reflected light signals in water measured by other devices. Therefore, apparatuses detect their motion regarding *the given medium*.

The observer who associates himself with physical objects thinks this. The optical signal in water moves regarding that substance to cover the distance between apparatuses. However, apparatuses C and D shows that illusion for the observer. They detect some constant motion (velocity V, equation 19) regarding some other medium because they keep their motionless location in the physical medium comprehensible for the observer. Therefore, despite observer’s speculations, a *light signal uses another reference frame of motion*.

Apparatuses E and F detect some motion regarding WRF because the duration of the forward signal becomes *unequal* to the duration of the backward signal. The full duration of the experiment coincides with

other experiments with reflected light signals measured by other devices in the vacuum. Therefore, apparatuses detect their motion regarding the given medium (vacuum) when “there is nothing to be removed”.

Magnitude and direction of velocity  $V$  (the speed of IRF in WRF) determined by the apparatuses E and F coincide with magnitude and direction of velocity determined by the apparatuses C and D. Therefore, those apparatuses (C, D, E and F) determine the same medium for light propagation. That is vacuum or pure space because pure space implicitly exists everywhere including all containers of the Trident Experiment.

Despite observer’s misunderstanding of that medium, apparatuses detect it without any problem. In other words, despite human’s point of view, light make propagation in space making physical interaction with pure space like any other wave in another medium.

An observer can change that speed by variation of fundamental properties of space that affect light propagation. Those are the permittivity and the magnetic permeability known for the modern observer. To detect other aspects which possibly influence the propagation of light, the observer should conduct experiments with SMA in some other place that have some deviation in those parameters.

As mentioned above, “ $\epsilon_0$ , the permittivity of free space, has an experimentally determined value of  $8.85 \times 10^{-12}$  square coulomb per newton square meter, and  $\mu_0$ , the magnetic permeability of free space, has a value of  $1.26 \times 10^{-6}$  newton square seconds per square coulomb.”

In other words, those known parameters have specific values. They are not zero, and they are not infinite. Therefore, they cause a limited speed of light by its physical interaction with pure space. Deviation of those parameters makes a variation in the speed of light in space.

#### XIV. AFTERMATH

SMA as a physical device destroys all postulates of relativity. A big number of postulates becomes a significant problem of any postulate-based theory. Destruction of one postulate leads to a consequent destruction of other postulates and the entire theory. Moreover, destruction of a theory leads to a consequent destruction of *all theories based on a given one*. That means cascade falsification of all dependent theories.

For example, “Einstein expressed these ideas in his deceptively simple principle of equivalence, which is the basis of General Relativity: *on a local scale—meaning within a given system, without looking at other systems—it is impossible to distinguish between physical effects due to gravity and those due to acceleration.*” (Relativity. (2008). Encyclopedia Britannica)

In case of SMA, the same observer uses two apparatuses in an isolated laboratory to determine his motion in space or in Light Wave Reference Frame (LWRF). Those are B or C elements of the Trident Experiment mentioned above and the linear mode of SMA. Two apparatuses determine the projection of observer-to-space velocity on the line connecting those apparatuses.

As long as the observer has the same ridings from SMA (a constant observer-to-space velocity) the observer understands this. *The force of gravity in the lab caused by some gravitational field instead of acceleration*. In other words, “principle of equivalence” becomes wrong for the lab with SMA. That experiment puts “principle of equivalence” to the category of postulates and destroys that postulate.

Therefore, SMA (and every element of technology that it uses) becomes the primary device of 21-th century physics because physical measurements of SMA cannot be reached by any other measurement device known ever before.

#### REFERENCES RÉFÉRENCES REFERENCIAS

1. Encyclopedia Britannica Deluxe Edition, Chicago, 2008.
2. Feist Norbert, “Acoustic Michelson-Morley Experiment with an Ultrasonic Range Finder”, *proceedings of the NPA*, Vol. 6, No. 2, (2010).
3. Cahill Reginald T., “The Roland De Witte 1991 Detection of Absolute Motion and Gravitational Waves”, *Progress in Physics* 3, 60-65, (2006).
4. Zade, Allan. “Philosophy, physics and mathematics of relative and absolute motion”. *International Journal of Physical Research*[Online], 4.2 (2016): 27-36. Web. 9 Jun. 2016
5. Einstein Albert, “On the electrodynamics of moving bodies”, published in a book *The Principle of Relativity*, Methuen and Company, Ltd., London, 1923.

# GLOBAL JOURNALS INC. (US) GUIDELINES HANDBOOK 2016

---

[WWW.GLOBALJOURNALS.ORG](http://WWW.GLOBALJOURNALS.ORG)

# FELLOWS

## FELLOW OF ASSOCIATION OF RESEARCH SOCIETY IN SCIENCE (FARSS)

Global Journals Incorporate (USA) is accredited by Open Association of Research Society (OARS), U.S.A and in turn, awards “FARSS” title to individuals. The 'FARSS' title is accorded to a selected professional after the approval of the Editor-in-Chief/Editorial Board Members/Dean.



- The “FARSS” is a dignified title which is accorded to a person’s name viz. Dr. John E. Hall, Ph.D., FARSS or William Walldroff, M.S., FARSS.

FARSS accrediting is an honor. It authenticates your research activities. After recognition as FARSS, you can add 'FARSS' title with your name as you use this recognition as additional suffix to your status. This will definitely enhance and add more value and reputation to your name. You may use it on your professional Counseling Materials such as CV, Resume, and Visiting Card etc.

*The following benefits can be availed by you only for next three years from the date of certification:*



FARSS designated members are entitled to avail a 40% discount while publishing their research papers (of a single author) with Global Journals Incorporation (USA), if the same is accepted by Editorial Board/Peer Reviewers. If you are a main author or co-author in case of multiple authors, you will be entitled to avail discount of 10%.

Once FARSS title is accorded, the Fellow is authorized to organize a symposium/seminar/conference on behalf of Global Journal Incorporation (USA). The Fellow can also participate in conference/seminar/symposium organized by another institution as representative of Global Journal. In both the cases, it is mandatory for him to discuss with us and obtain our consent.



You may join as member of the Editorial Board of Global Journals Incorporation (USA) after successful completion of three years as Fellow and as Peer Reviewer. In addition, it is also desirable that you should organize seminar/symposium/conference at least once.

We shall provide you intimation regarding launching of e-version of journal of your stream time to time. This may be utilized in your library for the enrichment of knowledge of your students as well as it can also be helpful for the concerned faculty members.







The FARSS can go through standards of OARS. You can also play vital role if you have any suggestions so that proper amendment can take place to improve the same for the benefit of entire research community.

As FARSS, you will be given a renowned, secure and free professional email address with 100 GB of space e.g. [johnhall@globaljournals.org](mailto:johnhall@globaljournals.org). This will include Webmail, Spam Assassin, Email Forwarders, Auto-Responders, Email Delivery Route tracing, etc.

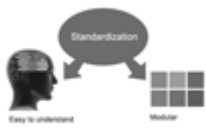

The FARSS will be eligible for a free application of standardization of their researches. Standardization of research will be subject to acceptability within stipulated norms as the next step after publishing in a journal. We shall depute a team of specialized research professionals who will render their services for elevating your researches to next higher level, which is worldwide open standardization.

The FARSS member can apply for grading and certification of standards of their educational and Institutional Degrees to Open Association of Research, Society U.S.A. Once you are designated as FARSS, you may send us a scanned copy of all of your credentials. OARS will verify, grade and certify them. This will be based on your academic records, quality of research papers published by you, and some more criteria. After certification of all your credentials by OARS, they will be published on your Fellow Profile link on website <https://associationofresearch.org> which will be helpful to upgrade the dignity.



The FARSS members can avail the benefits of free research podcasting in Global Research Radio with their research documents. After publishing the work, (including published elsewhere worldwide with proper authorization) you can upload your research paper with your recorded voice or you can utilize chargeable services of our professional RJs to record your paper in their voice on request.



The FARSS member also entitled to get the benefits of free research podcasting of their research documents through video clips. We can also streamline your conference videos and display your slides/ online slides and online research video clips at reasonable charges, on request.





The FARSS is eligible to earn from sales proceeds of his/her researches/reference/review Books or literature, while publishing with Global Journals. The FARSS can decide whether he/she would like to publish his/her research in a closed manner. In this case, whenever readers purchase that individual research paper for reading, maximum 60% of its profit earned as royalty by Global Journals, will be credited to his/her bank account. The entire entitled amount will be credited to his/her bank account exceeding limit of minimum fixed balance. There is no minimum time limit for collection. The FARSS member can decide its price and we can help in making the right decision.

The FARSS member is eligible to join as a paid peer reviewer at Global Journals Incorporation (USA) and can get remuneration of 15% of author fees, taken from the author of a respective paper. After reviewing 5 or more papers you can request to transfer the amount to your bank account.



## MEMBER OF ASSOCIATION OF RESEARCH SOCIETY IN SCIENCE (MARSS)

The ' MARSS ' title is accorded to a selected professional after the approval of the Editor-in-Chief / Editorial Board Members/Dean.

The “MARSS” is a dignified ornament which is accorded to a person’s name viz. Dr. John E. Hall, Ph.D., MARSS or William Walldroff, M.S., MARSS.



MARSS accrediting is an honor. It authenticates your research activities. After becoming MARSS, you can add 'MARSS' title with your name as you use this recognition as additional suffix to your status. This will definitely enhance and add more value and repute to your name. You may use it on your professional Counseling Materials such as CV, Resume, Visiting Card and Name Plate etc.

*The following benefits can be availed by you only for next three years from the date of certification.*



MARSS designated members are entitled to avail a 25% discount while publishing their research papers (of a single author) in Global Journals Inc., if the same is accepted by our Editorial Board and Peer Reviewers. If you are a main author or co-author of a group of authors, you will get discount of 10%.

As MARSS, you will be given a renowned, secure and free professional email address with 30 GB of space e.g. [johnhall@globaljournals.org](mailto:johnhall@globaljournals.org). This will include Webmail, Spam Assassin, Email Forwarders, Auto-Responders, Email Delivery Route tracing, etc.





We shall provide you intimation regarding launching of e-version of journal of your stream time to time. This may be utilized in your library for the enrichment of knowledge of your students as well as it can also be helpful for the concerned faculty members.

The MARSS member can apply for approval, grading and certification of standards of their educational and Institutional Degrees to Open Association of Research, Society U.S.A.



Once you are designated as MARSS, you may send us a scanned copy of all of your credentials. OARS will verify, grade and certify them. This will be based on your academic records, quality of research papers published by you, and some more criteria.

It is mandatory to read all terms and conditions carefully.



# AUXILIARY MEMBERSHIPS

## Institutional Fellow of Global Journals Incorporation (USA)-OARS (USA)

Global Journals Incorporation (USA) is accredited by Open Association of Research Society, U.S.A (OARS) and in turn, affiliates research institutions as “Institutional Fellow of Open Association of Research Society” (IFOARS).



The “FARSC” is a dignified title which is accorded to a person’s name viz. Dr. John E. Hall, Ph.D., FARSC or William Walldroff, M.S., FARSC.

The IFOARS institution is entitled to form a Board comprised of one Chairperson and three to five board members preferably from different streams. The Board will be recognized as “Institutional Board of Open Association of Research Society”-(IBOARS).

*The Institute will be entitled to following benefits:*



The IBOARS can initially review research papers of their institute and recommend them to publish with respective journal of Global Journals. It can also review the papers of other institutions after obtaining our consent. The second review will be done by peer reviewer of Global Journals Incorporation (USA) The Board is at liberty to appoint a peer reviewer with the approval of chairperson after consulting us.

The author fees of such paper may be waived off up to 40%.

The Global Journals Incorporation (USA) at its discretion can also refer double blind peer reviewed paper at their end to the board for the verification and to get recommendation for final stage of acceptance of publication.



The IBOARS can organize symposium/seminar/conference in their country on behalf of Global Journals Incorporation (USA)-OARS (USA). The terms and conditions can be discussed separately.

The Board can also play vital role by exploring and giving valuable suggestions regarding the Standards of “Open Association of Research Society, U.S.A (OARS)” so that proper amendment can take place for the benefit of entire research community. We shall provide details of particular standard only on receipt of request from the Board.



The board members can also join us as Individual Fellow with 40% discount on total fees applicable to Individual Fellow. They will be entitled to avail all the benefits as declared. Please visit Individual Fellow-sub menu of GlobalJournals.org to have more relevant details.



We shall provide you intimation regarding launching of e-version of journal of your stream time to time. This may be utilized in your library for the enrichment of knowledge of your students as well as it can also be helpful for the concerned faculty members.

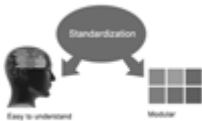

After nomination of your institution as “Institutional Fellow” and constantly functioning successfully for one year, we can consider giving recognition to your institute to function as Regional/Zonal office on our behalf. The board can also take up the additional allied activities for betterment after our consultation.

**The following entitlements are applicable to individual Fellows:**

Open Association of Research Society, U.S.A (OARS) By-laws states that an individual Fellow may use the designations as applicable, or the corresponding initials. The Credentials of individual Fellow and Associate designations signify that the individual has gained knowledge of the fundamental concepts. One is magnanimous and proficient in an expertise course covering the professional code of conduct, and follows recognized standards of practice.



Open Association of Research Society (US)/ Global Journals Incorporation (USA), as described in Corporate Statements, are educational, research publishing and professional membership organizations. Achieving our individual Fellow or Associate status is based mainly on meeting stated educational research requirements.

Disbursement of 40% Royalty earned through Global Journals : Researcher = 50%, Peer Reviewer = 37.50%, Institution = 12.50% E.g. Out of 40%, the 20% benefit should be passed on to researcher, 15 % benefit towards remuneration should be given to a reviewer and remaining 5% is to be retained by the institution.



We shall provide print version of 12 issues of any three journals [as per your requirement] out of our 38 journals worth \$ 2376 USD.

**Other:**

**The individual Fellow and Associate designations accredited by Open Association of Research Society (US) credentials signify guarantees following achievements:**

- The professional accredited with Fellow honor, is entitled to various benefits viz. name, fame, honor, regular flow of income, secured bright future, social status etc.



- In addition to above, if one is single author, then entitled to 40% discount on publishing research paper and can get 10% discount if one is co-author or main author among group of authors.
- The Fellow can organize symposium/seminar/conference on behalf of Global Journals Incorporation (USA) and he/she can also attend the same organized by other institutes on behalf of Global Journals.
- The Fellow can become member of Editorial Board Member after completing 3yrs.
- The Fellow can earn 60% of sales proceeds from the sale of reference/review books/literature/publishing of research paper.
- Fellow can also join as paid peer reviewer and earn 15% remuneration of author charges and can also get an opportunity to join as member of the Editorial Board of Global Journals Incorporation (USA)
- • This individual has learned the basic methods of applying those concepts and techniques to common challenging situations. This individual has further demonstrated an in-depth understanding of the application of suitable techniques to a particular area of research practice.

**Note :**

//

- In future, if the board feels the necessity to change any board member, the same can be done with the consent of the chairperson along with anyone board member without our approval.
- In case, the chairperson needs to be replaced then consent of 2/3rd board members are required and they are also required to jointly pass the resolution copy of which should be sent to us. In such case, it will be compulsory to obtain our approval before replacement.
- In case of “Difference of Opinion [if any]” among the Board members, our decision will be final and binding to everyone.

//



## PROCESS OF SUBMISSION OF RESEARCH PAPER

---

The Area or field of specialization may or may not be of any category as mentioned in 'Scope of Journal' menu of the GlobalJournals.org website. There are 37 Research Journal categorized with Six parental Journals GJCST, GJMR, GJRE, GJMBR, GJSFR, GJHSS. For Authors should prefer the mentioned categories. There are three widely used systems UDC, DDC and LCC. The details are available as 'Knowledge Abstract' at Home page. The major advantage of this coding is that, the research work will be exposed to and shared with all over the world as we are being abstracted and indexed worldwide.

The paper should be in proper format. The format can be downloaded from first page of 'Author Guideline' Menu. The Author is expected to follow the general rules as mentioned in this menu. The paper should be written in MS-Word Format (\*.DOC,\*.DOCX).

The Author can submit the paper either online or offline. The authors should prefer online submission.Online Submission: There are three ways to submit your paper:

**(A) (I) First, register yourself using top right corner of Home page then Login. If you are already registered, then login using your username and password.**

**(II) Choose corresponding Journal.**

**(III) Click 'Submit Manuscript'. Fill required information and Upload the paper.**

**(B) If you are using Internet Explorer, then Direct Submission through Homepage is also available.**

**(C) If these two are not convenient, and then email the paper directly to dean@globaljournals.org.**

Offline Submission: Author can send the typed form of paper by Post. However, online submission should be preferred.



# PREFERRED AUTHOR GUIDELINES

## MANUSCRIPT STYLE INSTRUCTION (Must be strictly followed)

Page Size: 8.27" X 11"

- Left Margin: 0.65
- Right Margin: 0.65
- Top Margin: 0.75
- Bottom Margin: 0.75
- Font type of all text should be Swis 721 Lt BT.
- Paper Title should be of Font Size 24 with one Column section.
- Author Name in Font Size of 11 with one column as of Title.
- Abstract Font size of 9 Bold, "Abstract" word in Italic Bold.
- Main Text: Font size 10 with justified two columns section
- Two Column with Equal Column with of 3.38 and Gaping of .2
- First Character must be three lines Drop capped.
- Paragraph before Spacing of 1 pt and After of 0 pt.
- Line Spacing of 1 pt
- Large Images must be in One Column
- Numbering of First Main Headings (Heading 1) must be in Roman Letters, Capital Letter, and Font Size of 10.
- Numbering of Second Main Headings (Heading 2) must be in Alphabets, Italic, and Font Size of 10.

**You can use your own standard format also.**

### Author Guidelines:

1. General,
2. Ethical Guidelines,
3. Submission of Manuscripts,
4. Manuscript's Category,
5. Structure and Format of Manuscript,
6. After Acceptance.

### 1. GENERAL

Before submitting your research paper, one is advised to go through the details as mentioned in following heads. It will be beneficial, while peer reviewer justify your paper for publication.

### Scope

The Global Journals Inc. (US) welcome the submission of original paper, review paper, survey article relevant to the all the streams of Philosophy and knowledge. The Global Journals Inc. (US) is parental platform for Global Journal of Computer Science and Technology, Researches in Engineering, Medical Research, Science Frontier Research, Human Social Science, Management, and Business organization. The choice of specific field can be done otherwise as following in Abstracting and Indexing Page on this Website. As the all Global



Journals Inc. (US) are being abstracted and indexed (in process) by most of the reputed organizations. Topics of only narrow interest will not be accepted unless they have wider potential or consequences.

## 2. ETHICAL GUIDELINES

Authors should follow the ethical guidelines as mentioned below for publication of research paper and research activities.

Papers are accepted on strict understanding that the material in whole or in part has not been, nor is being, considered for publication elsewhere. If the paper once accepted by Global Journals Inc. (US) and Editorial Board, will become the copyright of the Global Journals Inc. (US).

**Authorship: The authors and coauthors should have active contribution to conception design, analysis and interpretation of findings. They should critically review the contents and drafting of the paper. All should approve the final version of the paper before submission**

The Global Journals Inc. (US) follows the definition of authorship set up by the Global Academy of Research and Development. According to the Global Academy of R&D authorship, criteria must be based on:

- 1) Substantial contributions to conception and acquisition of data, analysis and interpretation of the findings.
- 2) Drafting the paper and revising it critically regarding important academic content.
- 3) Final approval of the version of the paper to be published.

All authors should have been credited according to their appropriate contribution in research activity and preparing paper. Contributors who do not match the criteria as authors may be mentioned under Acknowledgement.

Acknowledgements: Contributors to the research other than authors credited should be mentioned under acknowledgement. The specifications of the source of funding for the research if appropriate can be included. Suppliers of resources may be mentioned along with address.

**Appeal of Decision: The Editorial Board's decision on publication of the paper is final and cannot be appealed elsewhere.**

**Permissions: It is the author's responsibility to have prior permission if all or parts of earlier published illustrations are used in this paper.**

Please mention proper reference and appropriate acknowledgements wherever expected.

If all or parts of previously published illustrations are used, permission must be taken from the copyright holder concerned. It is the author's responsibility to take these in writing.

Approval for reproduction/modification of any information (including figures and tables) published elsewhere must be obtained by the authors/copyright holders before submission of the manuscript. Contributors (Authors) are responsible for any copyright fee involved.

## 3. SUBMISSION OF MANUSCRIPTS

Manuscripts should be uploaded via this online submission page. The online submission is most efficient method for submission of papers, as it enables rapid distribution of manuscripts and consequently speeds up the review procedure. It also enables authors to know the status of their own manuscripts by emailing us. Complete instructions for submitting a paper is available below.

Manuscript submission is a systematic procedure and little preparation is required beyond having all parts of your manuscript in a given format and a computer with an Internet connection and a Web browser. Full help and instructions are provided on-screen. As an author, you will be prompted for login and manuscript details as Field of Paper and then to upload your manuscript file(s) according to the instructions.



To avoid postal delays, all transaction is preferred by e-mail. A finished manuscript submission is confirmed by e-mail immediately and your paper enters the editorial process with no postal delays. When a conclusion is made about the publication of your paper by our Editorial Board, revisions can be submitted online with the same procedure, with an occasion to view and respond to all comments.

Complete support for both authors and co-author is provided.

#### 4. MANUSCRIPT'S CATEGORY

Based on potential and nature, the manuscript can be categorized under the following heads:

Original research paper: Such papers are reports of high-level significant original research work.

Review papers: These are concise, significant but helpful and decisive topics for young researchers.

Research articles: These are handled with small investigation and applications

Research letters: The letters are small and concise comments on previously published matters.

#### 5. STRUCTURE AND FORMAT OF MANUSCRIPT

The recommended size of original research paper is less than seven thousand words, review papers fewer than seven thousands words also. Preparation of research paper or how to write research paper, are major hurdle, while writing manuscript. The research articles and research letters should be fewer than three thousand words, the structure original research paper; sometime review paper should be as follows:

**Papers:** These are reports of significant research (typically less than 7000 words equivalent, including tables, figures, references), and comprise:

(a) Title should be relevant and commensurate with the theme of the paper.

(b) A brief Summary, "Abstract" (less than 150 words) containing the major results and conclusions.

(c) Up to ten keywords, that precisely identifies the paper's subject, purpose, and focus.

(d) An Introduction, giving necessary background excluding subheadings; objectives must be clearly declared.

(e) Resources and techniques with sufficient complete experimental details (wherever possible by reference) to permit repetition; sources of information must be given and numerical methods must be specified by reference, unless non-standard.

(f) Results should be presented concisely, by well-designed tables and/or figures; the same data may not be used in both; suitable statistical data should be given. All data must be obtained with attention to numerical detail in the planning stage. As reproduced design has been recognized to be important to experiments for a considerable time, the Editor has decided that any paper that appears not to have adequate numerical treatments of the data will be returned un-refereed;

(g) Discussion should cover the implications and consequences, not just recapitulating the results; conclusions should be summarizing.

(h) Brief Acknowledgements.

(i) References in the proper form.

Authors should very cautiously consider the preparation of papers to ensure that they communicate efficiently. Papers are much more likely to be accepted, if they are cautiously designed and laid out, contain few or no errors, are summarizing, and be conventional to the approach and instructions. They will in addition, be published with much less delays than those that require much technical and editorial correction.



The Editorial Board reserves the right to make literary corrections and to make suggestions to improve brevity.

It is vital, that authors take care in submitting a manuscript that is written in simple language and adheres to published guidelines.

## Format

*Language: The language of publication is UK English. Authors, for whom English is a second language, must have their manuscript efficiently edited by an English-speaking person before submission to make sure that, the English is of high excellence. It is preferable, that manuscripts should be professionally edited.*

Standard Usage, Abbreviations, and Units: Spelling and hyphenation should be conventional to The Concise Oxford English Dictionary. Statistics and measurements should at all times be given in figures, e.g. 16 min, except for when the number begins a sentence. When the number does not refer to a unit of measurement it should be spelt in full unless, it is 160 or greater.

Abbreviations supposed to be used carefully. The abbreviated name or expression is supposed to be cited in full at first usage, followed by the conventional abbreviation in parentheses.

Metric SI units are supposed to generally be used excluding where they conflict with current practice or are confusing. For illustration, 1.4 l rather than  $1.4 \times 10^{-3} \text{ m}^3$ , or 4 mm somewhat than  $4 \times 10^{-3} \text{ m}$ . Chemical formula and solutions must identify the form used, e.g. anhydrous or hydrated, and the concentration must be in clearly defined units. Common species names should be followed by underlines at the first mention. For following use the generic name should be constricted to a single letter, if it is clear.

## Structure

All manuscripts submitted to Global Journals Inc. (US), ought to include:

Title: The title page must carry an instructive title that reflects the content, a running title (less than 45 characters together with spaces), names of the authors and co-authors, and the place(s) wherever the work was carried out. The full postal address in addition with the e-mail address of related author must be given. Up to eleven keywords or very brief phrases have to be given to help data retrieval, mining and indexing.

*Abstract, used in Original Papers and Reviews:*

### Optimizing Abstract for Search Engines

Many researchers searching for information online will use search engines such as Google, Yahoo or similar. By optimizing your paper for search engines, you will amplify the chance of someone finding it. This in turn will make it more likely to be viewed and/or cited in a further work. Global Journals Inc. (US) have compiled these guidelines to facilitate you to maximize the web-friendliness of the most public part of your paper.

### Key Words

A major linchpin in research work for the writing research paper is the keyword search, which one will employ to find both library and Internet resources.

One must be persistent and creative in using keywords. An effective keyword search requires a strategy and planning a list of possible keywords and phrases to try.

Search engines for most searches, use Boolean searching, which is somewhat different from Internet searches. The Boolean search uses "operators," words (and, or, not, and near) that enable you to expand or narrow your affords. Tips for research paper while preparing research paper are very helpful guideline of research paper.

Choice of key words is first tool of tips to write research paper. Research paper writing is an art. A few tips for deciding as strategically as possible about keyword search:



- One should start brainstorming lists of possible keywords before even begin searching. Think about the most important concepts related to research work. Ask, "What words would a source have to include to be truly valuable in research paper?" Then consider synonyms for the important words.
- It may take the discovery of only one relevant paper to let steer in the right keyword direction because in most databases, the keywords under which a research paper is abstracted are listed with the paper.
- One should avoid outdated words.

Keywords are the key that opens a door to research work sources. Keyword searching is an art in which researcher's skills are bound to improve with experience and time.

Numerical Methods: Numerical methods used should be clear and, where appropriate, supported by references.

*Acknowledgements: Please make these as concise as possible.*

#### References

References follow the Harvard scheme of referencing. References in the text should cite the authors' names followed by the time of their publication, unless there are three or more authors when simply the first author's name is quoted followed by et al. unpublished work has to only be cited where necessary, and only in the text. Copies of references in press in other journals have to be supplied with submitted typescripts. It is necessary that all citations and references be carefully checked before submission, as mistakes or omissions will cause delays.

References to information on the World Wide Web can be given, but only if the information is available without charge to readers on an official site. Wikipedia and Similar websites are not allowed where anyone can change the information. Authors will be asked to make available electronic copies of the cited information for inclusion on the Global Journals Inc. (US) homepage at the judgment of the Editorial Board.

The Editorial Board and Global Journals Inc. (US) recommend that, citation of online-published papers and other material should be done via a DOI (digital object identifier). If an author cites anything, which does not have a DOI, they run the risk of the cited material not being noticeable.

The Editorial Board and Global Journals Inc. (US) recommend the use of a tool such as Reference Manager for reference management and formatting.

#### Tables, Figures and Figure Legends

*Tables: Tables should be few in number, cautiously designed, uncrowned, and include only essential data. Each must have an Arabic number, e.g. Table 4, a self-explanatory caption and be on a separate sheet. Vertical lines should not be used.*

*Figures: Figures are supposed to be submitted as separate files. Always take in a citation in the text for each figure using Arabic numbers, e.g. Fig. 4. Artwork must be submitted online in electronic form by e-mailing them.*

#### Preparation of Electronic Figures for Publication

Even though low quality images are sufficient for review purposes, print publication requires high quality images to prevent the final product being blurred or fuzzy. Submit (or e-mail) EPS (line art) or TIFF (halftone/photographs) files only. MS PowerPoint and Word Graphics are unsuitable for printed pictures. Do not use pixel-oriented software. Scans (TIFF only) should have a resolution of at least 350 dpi (halftone) or 700 to 1100 dpi (line drawings) in relation to the imitation size. Please give the data for figures in black and white or submit a Color Work Agreement Form. EPS files must be saved with fonts embedded (and with a TIFF preview, if possible).

For scanned images, the scanning resolution (at final image size) ought to be as follows to ensure good reproduction: line art: >650 dpi; halftones (including gel photographs) : >350 dpi; figures containing both halftone and line images: >650 dpi.



Color Charges: It is the rule of the Global Journals Inc. (US) for authors to pay the full cost for the reproduction of their color artwork. Hence, please note that, if there is color artwork in your manuscript when it is accepted for publication, we would require you to complete and return a color work agreement form before your paper can be published.

*Figure Legends: Self-explanatory legends of all figures should be incorporated separately under the heading 'Legends to Figures'. In the full-text online edition of the journal, figure legends may possibly be truncated in abbreviated links to the full screen version. Therefore, the first 100 characters of any legend should notify the reader, about the key aspects of the figure.*

## **6. AFTER ACCEPTANCE**

Upon approval of a paper for publication, the manuscript will be forwarded to the dean, who is responsible for the publication of the Global Journals Inc. (US).

### **6.1 Proof Corrections**

The corresponding author will receive an e-mail alert containing a link to a website or will be attached. A working e-mail address must therefore be provided for the related author.

Acrobat Reader will be required in order to read this file. This software can be downloaded

(Free of charge) from the following website:

[www.adobe.com/products/acrobat/readstep2.html](http://www.adobe.com/products/acrobat/readstep2.html). This will facilitate the file to be opened, read on screen, and printed out in order for any corrections to be added. Further instructions will be sent with the proof.

Proofs must be returned to the dean at [dean@globaljournals.org](mailto:dean@globaljournals.org) within three days of receipt.

As changes to proofs are costly, we inquire that you only correct typesetting errors. All illustrations are retained by the publisher. Please note that the authors are responsible for all statements made in their work, including changes made by the copy editor.

### **6.2 Early View of Global Journals Inc. (US) (Publication Prior to Print)**

The Global Journals Inc. (US) are enclosed by our publishing's Early View service. Early View articles are complete full-text articles sent in advance of their publication. Early View articles are absolute and final. They have been completely reviewed, revised and edited for publication, and the authors' final corrections have been incorporated. Because they are in final form, no changes can be made after sending them. The nature of Early View articles means that they do not yet have volume, issue or page numbers, so Early View articles cannot be cited in the conventional way.

### **6.3 Author Services**

Online production tracking is available for your article through Author Services. Author Services enables authors to track their article - once it has been accepted - through the production process to publication online and in print. Authors can check the status of their articles online and choose to receive automated e-mails at key stages of production. The authors will receive an e-mail with a unique link that enables them to register and have their article automatically added to the system. Please ensure that a complete e-mail address is provided when submitting the manuscript.

### **6.4 Author Material Archive Policy**

Please note that if not specifically requested, publisher will dispose off hardcopy & electronic information submitted, after the two months of publication. If you require the return of any information submitted, please inform the Editorial Board or dean as soon as possible.

### **6.5 Offprint and Extra Copies**

A PDF offprint of the online-published article will be provided free of charge to the related author, and may be distributed according to the Publisher's terms and conditions. Additional paper offprint may be ordered by emailing us at: [editor@globaljournals.org](mailto:editor@globaljournals.org) .



Before start writing a good quality Computer Science Research Paper, let us first understand what is Computer Science Research Paper? So, Computer Science Research Paper is the paper which is written by professionals or scientists who are associated to Computer Science and Information Technology, or doing research study in these areas. If you are novel to this field then you can consult about this field from your supervisor or guide.

#### TECHNIQUES FOR WRITING A GOOD QUALITY RESEARCH PAPER:

**1. Choosing the topic:** In most cases, the topic is searched by the interest of author but it can be also suggested by the guides. You can have several topics and then you can judge that in which topic or subject you are finding yourself most comfortable. This can be done by asking several questions to yourself, like Will I be able to carry our search in this area? Will I find all necessary recourses to accomplish the search? Will I be able to find all information in this field area? If the answer of these types of questions will be "Yes" then you can choose that topic. In most of the cases, you may have to conduct the surveys and have to visit several places because this field is related to Computer Science and Information Technology. Also, you may have to do a lot of work to find all rise and falls regarding the various data of that subject. Sometimes, detailed information plays a vital role, instead of short information.

**2. Evaluators are human:** First thing to remember that evaluators are also human being. They are not only meant for rejecting a paper. They are here to evaluate your paper. So, present your Best.

**3. Think Like Evaluators:** If you are in a confusion or getting demotivated that your paper will be accepted by evaluators or not, then think and try to evaluate your paper like an Evaluator. Try to understand that what an evaluator wants in your research paper and automatically you will have your answer.

**4. Make blueprints of paper:** The outline is the plan or framework that will help you to arrange your thoughts. It will make your paper logical. But remember that all points of your outline must be related to the topic you have chosen.

**5. Ask your Guides:** If you are having any difficulty in your research, then do not hesitate to share your difficulty to your guide (if you have any). They will surely help you out and resolve your doubts. If you can't clarify what exactly you require for your work then ask the supervisor to help you with the alternative. He might also provide you the list of essential readings.

**6. Use of computer is recommended:** As you are doing research in the field of Computer Science, then this point is quite obvious.

**7. Use right software:** Always use good quality software packages. If you are not capable to judge good software then you can lose quality of your paper unknowingly. There are various software programs available to help you, which you can get through Internet.

**8. Use the Internet for help:** An excellent start for your paper can be by using the Google. It is an excellent search engine, where you can have your doubts resolved. You may also read some answers for the frequent question how to write my research paper or find model research paper. From the internet library you can download books. If you have all required books make important reading selecting and analyzing the specified information. Then put together research paper sketch out.

**9. Use and get big pictures:** Always use encyclopedias, Wikipedia to get pictures so that you can go into the depth.

**10. Bookmarks are useful:** When you read any book or magazine, you generally use bookmarks, right! It is a good habit, which helps to not to lose your continuity. You should always use bookmarks while searching on Internet also, which will make your search easier.

**11. Revise what you wrote:** When you write anything, always read it, summarize it and then finalize it.



**12. Make all efforts:** Make all efforts to mention what you are going to write in your paper. That means always have a good start. Try to mention everything in introduction, that what is the need of a particular research paper. Polish your work by good skill of writing and always give an evaluator, what he wants.

**13. Have backups:** When you are going to do any important thing like making research paper, you should always have backup copies of it either in your computer or in paper. This will help you to not to lose any of your important.

**14. Produce good diagrams of your own:** Always try to include good charts or diagrams in your paper to improve quality. Using several and unnecessary diagrams will degrade the quality of your paper by creating "hotchpotch." So always, try to make and include those diagrams, which are made by your own to improve readability and understandability of your paper.

**15. Use of direct quotes:** When you do research relevant to literature, history or current affairs then use of quotes become essential but if study is relevant to science then use of quotes is not preferable.

**16. Use proper verb tense:** Use proper verb tenses in your paper. Use past tense, to present those events that happened. Use present tense to indicate events that are going on. Use future tense to indicate future happening events. Use of improper and wrong tenses will confuse the evaluator. Avoid the sentences that are incomplete.

**17. Never use online paper:** If you are getting any paper on Internet, then never use it as your research paper because it might be possible that evaluator has already seen it or maybe it is outdated version.

**18. Pick a good study spot:** To do your research studies always try to pick a spot, which is quiet. Every spot is not for studies. Spot that suits you choose it and proceed further.

**19. Know what you know:** Always try to know, what you know by making objectives. Else, you will be confused and cannot achieve your target.

**20. Use good quality grammar:** Always use a good quality grammar and use words that will throw positive impact on evaluator. Use of good quality grammar does not mean to use tough words, that for each word the evaluator has to go through dictionary. Do not start sentence with a conjunction. Do not fragment sentences. Eliminate one-word sentences. Ignore passive voice. Do not ever use a big word when a diminutive one would suffice. Verbs have to be in agreement with their subjects. Prepositions are not expressions to finish sentences with. It is incorrect to ever divide an infinitive. Avoid clichés like the disease. Also, always shun irritating alliteration. Use language that is simple and straight forward. put together a neat summary.

**21. Arrangement of information:** Each section of the main body should start with an opening sentence and there should be a changeover at the end of the section. Give only valid and powerful arguments to your topic. You may also maintain your arguments with records.

**22. Never start in last minute:** Always start at right time and give enough time to research work. Leaving everything to the last minute will degrade your paper and spoil your work.

**23. Multitasking in research is not good:** Doing several things at the same time proves bad habit in case of research activity. Research is an area, where everything has a particular time slot. Divide your research work in parts and do particular part in particular time slot.

**24. Never copy others' work:** Never copy others' work and give it your name because if evaluator has seen it anywhere you will be in trouble.

**25. Take proper rest and food:** No matter how many hours you spend for your research activity, if you are not taking care of your health then all your efforts will be in vain. For a quality research, study is must, and this can be done by taking proper rest and food.

**26. Go for seminars:** Attend seminars if the topic is relevant to your research area. Utilize all your resources.



**27. Refresh your mind after intervals:** Try to give rest to your mind by listening to soft music or by sleeping in intervals. This will also improve your memory.

**28. Make colleagues:** Always try to make colleagues. No matter how sharper or intelligent you are, if you make colleagues you can have several ideas, which will be helpful for your research.

**29. Think technically:** Always think technically. If anything happens, then search its reasons, its benefits, and demerits.

**30. Think and then print:** When you will go to print your paper, notice that tables are not be split, headings are not detached from their descriptions, and page sequence is maintained.

**31. Adding unnecessary information:** Do not add unnecessary information, like, I have used MS Excel to draw graph. Do not add irrelevant and inappropriate material. These all will create superfluous. Foreign terminology and phrases are not apropos. One should NEVER take a broad view. Analogy in script is like feathers on a snake. Not at all use a large word when a very small one would be sufficient. Use words properly, regardless of how others use them. Remove quotations. Puns are for kids, not grunt readers. Amplification is a billion times of inferior quality than sarcasm.

**32. Never oversimplify everything:** To add material in your research paper, never go for oversimplification. This will definitely irritate the evaluator. Be more or less specific. Also too, by no means, ever use rhythmic redundancies. Contractions aren't essential and shouldn't be there used. Comparisons are as terrible as clichés. Give up ampersands and abbreviations, and so on. Remove commas, that are, not necessary. Parenthetical words however should be together with this in commas. Understatement is all the time the complete best way to put onward earth-shaking thoughts. Give a detailed literary review.

**33. Report concluded results:** Use concluded results. From raw data, filter the results and then conclude your studies based on measurements and observations taken. Significant figures and appropriate number of decimal places should be used. Parenthetical remarks are prohibitive. Proofread carefully at final stage. In the end give outline to your arguments. Spot out perspectives of further study of this subject. Justify your conclusion by at the bottom of them with sufficient justifications and examples.

**34. After conclusion:** Once you have concluded your research, the next most important step is to present your findings. Presentation is extremely important as it is the definite medium through which your research is going to be in print to the rest of the crowd. Care should be taken to categorize your thoughts well and present them in a logical and neat manner. A good quality research paper format is essential because it serves to highlight your research paper and bring to light all necessary aspects in your research.

## INFORMAL GUIDELINES OF RESEARCH PAPER WRITING

### Key points to remember:

- Submit all work in its final form.
- Write your paper in the form, which is presented in the guidelines using the template.
- Please note the criterion for grading the final paper by peer-reviewers.

### Final Points:

A purpose of organizing a research paper is to let people to interpret your effort selectively. The journal requires the following sections, submitted in the order listed, each section to start on a new page.

The introduction will be compiled from reference matter and will reflect the design processes or outline of basis that direct you to make study. As you will carry out the process of study, the method and process section will be constructed as like that. The result segment will show related statistics in nearly sequential order and will direct the reviewers next to the similar intellectual paths throughout the data that you took to carry out your study. The discussion section will provide understanding of the data and projections as to the implication of the results. The use of good quality references all through the paper will give the effort trustworthiness by representing an alertness of prior workings.





Writing a research paper is not an easy job no matter how trouble-free the actual research or concept. Practice, excellent preparation, and controlled record keeping are the only means to make straightforward the progression.

**General style:**

Specific editorial column necessities for compliance of a manuscript will always take over from directions in these general guidelines.

To make a paper clear

- Adhere to recommended page limits

Mistakes to evade

- Insertion a title at the foot of a page with the subsequent text on the next page
- Separating a table/chart or figure - impound each figure/table to a single page
- Submitting a manuscript with pages out of sequence

In every sections of your document

- Use standard writing style including articles ("a", "the," etc.)
- Keep on paying attention on the research topic of the paper
- Use paragraphs to split each significant point (excluding for the abstract)
- Align the primary line of each section
- Present your points in sound order
- Use present tense to report well accepted
- Use past tense to describe specific results
- Shun familiar wording, don't address the reviewer directly, and don't use slang, slang language, or superlatives
- Shun use of extra pictures - include only those figures essential to presenting results

**Title Page:**

Choose a revealing title. It should be short. It should not have non-standard acronyms or abbreviations. It should not exceed two printed lines. It should include the name(s) and address (es) of all authors.



## Abstract:

The summary should be two hundred words or less. It should briefly and clearly explain the key findings reported in the manuscript-- must have precise statistics. It should not have abnormal acronyms or abbreviations. It should be logical in itself. Shun citing references at this point.

An abstract is a brief distinct paragraph summary of finished work or work in development. In a minute or less a reviewer can be taught the foundation behind the study, common approach to the problem, relevant results, and significant conclusions or new questions.

Write your summary when your paper is completed because how can you write the summary of anything which is not yet written? Wealth of terminology is very essential in abstract. Yet, use comprehensive sentences and do not let go readability for brevity. You can maintain it succinct by phrasing sentences so that they provide more than lone rationale. The author can at this moment go straight to shortening the outcome. Sum up the study, with the subsequent elements in any summary. Try to maintain the initial two items to no more than one ruling each.

- Reason of the study - theory, overall issue, purpose
- Fundamental goal
- To the point depiction of the research
- Consequences, including definite statistics - if the consequences are quantitative in nature, account quantitative data; results of any numerical analysis should be reported
- Significant conclusions or questions that track from the research(es)

## Approach:

- Single section, and succinct
- As an outline of job done, it is always written in past tense
- A conceptual should situate on its own, and not submit to any other part of the paper such as a form or table
- Center on shortening results - bound background information to a verdict or two, if completely necessary
- What you account in an abstract must be regular with what you reported in the manuscript
- Exact spelling, clearness of sentences and phrases, and appropriate reporting of quantities (proper units, important statistics) are just as significant in an abstract as they are anywhere else

## Introduction:

The **Introduction** should "introduce" the manuscript. The reviewer should be presented with sufficient background information to be capable to comprehend and calculate the purpose of your study without having to submit to other works. The basis for the study should be offered. Give most important references but shun difficult to make a comprehensive appraisal of the topic. In the introduction, describe the problem visibly. If the problem is not acknowledged in a logical, reasonable way, the reviewer will have no attention in your result. Speak in common terms about techniques used to explain the problem, if needed, but do not present any particulars about the protocols here. Following approach can create a valuable beginning:

- Explain the value (significance) of the study
- Shield the model - why did you employ this particular system or method? What is its compensation? You strength remark on its appropriateness from a abstract point of vision as well as point out sensible reasons for using it.
- Present a justification. Status your particular theory (es) or aim(s), and describe the logic that led you to choose them.
- Very for a short time explain the tentative propose and how it skilled the declared objectives.

## Approach:

- Use past tense except for when referring to recognized facts. After all, the manuscript will be submitted after the entire job is done.
- Sort out your thoughts; manufacture one key point with every section. If you make the four points listed above, you will need a least of four paragraphs.



- Present surroundings information only as desirable in order hold up a situation. The reviewer does not desire to read the whole thing you know about a topic.
- Shape the theory/purpose specifically - do not take a broad view.
- As always, give awareness to spelling, simplicity and correctness of sentences and phrases.

#### **Procedures (Methods and Materials):**

This part is supposed to be the easiest to carve if you have good skills. A sound written Procedures segment allows a capable scientist to replacement your results. Present precise information about your supplies. The suppliers and clarity of reagents can be helpful bits of information. Present methods in sequential order but linked methodologies can be grouped as a segment. Be concise when relating the protocols. Attempt for the least amount of information that would permit another capable scientist to spare your outcome but be cautious that vital information is integrated. The use of subheadings is suggested and ought to be synchronized with the results section. When a technique is used that has been well described in another object, mention the specific item describing a way but draw the basic principle while stating the situation. The purpose is to text all particular resources and broad procedures, so that another person may use some or all of the methods in one more study or referee the scientific value of your work. It is not to be a step by step report of the whole thing you did, nor is a methods section a set of orders.

#### **Materials:**

- Explain materials individually only if the study is so complex that it saves liberty this way.
- Embrace particular materials, and any tools or provisions that are not frequently found in laboratories.
- Do not take in frequently found.
- If use of a definite type of tools.
- Materials may be reported in a part section or else they may be recognized along with your measures.

#### **Methods:**

- Report the method (not particulars of each process that engaged the same methodology)
- Describe the method entirely
- To be succinct, present methods under headings dedicated to specific dealings or groups of measures
- Simplify - details how procedures were completed not how they were exclusively performed on a particular day.
- If well known procedures were used, account the procedure by name, possibly with reference, and that's all.

#### **Approach:**

- It is embarrassed or not possible to use vigorous voice when documenting methods with no using first person, which would focus the reviewer's interest on the researcher rather than the job. As a result when script up the methods most authors use third person passive voice.
- Use standard style in this and in every other part of the paper - avoid familiar lists, and use full sentences.

#### **What to keep away from**

- Resources and methods are not a set of information.
- Skip all descriptive information and surroundings - save it for the argument.
- Leave out information that is immaterial to a third party.

#### **Results:**

The principle of a results segment is to present and demonstrate your conclusion. Create this part a entirely objective details of the outcome, and save all understanding for the discussion.

The page length of this segment is set by the sum and types of data to be reported. Carry on to be to the point, by means of statistics and tables, if suitable, to present consequences most efficiently. You must obviously differentiate material that would usually be incorporated in a study editorial from any unprocessed data or additional appendix matter that would not be available. In fact, such matter should not be submitted at all except requested by the instructor.



## Content

- Sum up your conclusion in text and demonstrate them, if suitable, with figures and tables.
- In manuscript, explain each of your consequences, point the reader to remarks that are most appropriate.
- Present a background, such as by describing the question that was addressed by creation an exacting study.
- Explain results of control experiments and comprise remarks that are not accessible in a prescribed figure or table, if appropriate.
- Examine your data, then prepare the analyzed (transformed) data in the form of a figure (graph), table, or in manuscript form.

### What to stay away from

- Do not discuss or infer your outcome, report surroundings information, or try to explain anything.
- Not at all, take in raw data or intermediate calculations in a research manuscript.
- Do not present the similar data more than once.
- Manuscript should complement any figures or tables, not duplicate the identical information.
- Never confuse figures with tables - there is a difference.

### Approach

- As forever, use past tense when you submit to your results, and put the whole thing in a reasonable order.
- Put figures and tables, appropriately numbered, in order at the end of the report
- If you desire, you may place your figures and tables properly within the text of your results part.

### Figures and tables

- If you put figures and tables at the end of the details, make certain that they are visibly distinguished from any attach appendix materials, such as raw facts
- Despite of position, each figure must be numbered one after the other and complete with subtitle
- In spite of position, each table must be titled, numbered one after the other and complete with heading
- All figure and table must be adequately complete that it could situate on its own, divide from text

### Discussion:

The Discussion is expected the trickiest segment to write and describe. A lot of papers submitted for journal are discarded based on problems with the Discussion. There is no head of state for how long a argument should be. Position your understanding of the outcome visibly to lead the reviewer through your conclusions, and then finish the paper with a summing up of the implication of the study. The purpose here is to offer an understanding of your results and hold up for all of your conclusions, using facts from your research and generally accepted information, if suitable. The implication of result should be visibly described. Infer your data in the conversation in suitable depth. This means that when you clarify an observable fact you must explain mechanisms that may account for the observation. If your results vary from your prospect, make clear why that may have happened. If your results agree, then explain the theory that the proof supported. It is never suitable to just state that the data approved with prospect, and let it drop at that.

- Make a decision if each premise is supported, discarded, or if you cannot make a conclusion with assurance. Do not just dismiss a study or part of a study as "uncertain."
- Research papers are not acknowledged if the work is imperfect. Draw what conclusions you can based upon the results that you have, and take care of the study as a finished work
- You may propose future guidelines, such as how the experiment might be personalized to accomplish a new idea.
- Give details all of your remarks as much as possible, focus on mechanisms.
- Make a decision if the tentative design sufficiently addressed the theory, and whether or not it was correctly restricted.
- Try to present substitute explanations if sensible alternatives be present.
- One research will not counter an overall question, so maintain the large picture in mind, where do you go next? The best studies unlock new avenues of study. What questions remain?
- Recommendations for detailed papers will offer supplementary suggestions.

### Approach:

- When you refer to information, differentiate data generated by your own studies from available information
- Submit to work done by specific persons (including you) in past tense.
- Submit to generally acknowledged facts and main beliefs in present tense.



## THE ADMINISTRATION RULES

Please carefully note down following rules and regulation before submitting your Research Paper to Global Journals Inc. (US):

**Segment Draft and Final Research Paper:** You have to strictly follow the template of research paper. If it is not done your paper may get rejected.

- The **major constraint** is that you must independently make all content, tables, graphs, and facts that are offered in the paper. You must write each part of the paper wholly on your own. The Peer-reviewers need to identify your own perceptives of the concepts in your own terms. NEVER extract straight from any foundation, and never rephrase someone else's analysis.
- Do not give permission to anyone else to "PROOFREAD" your manuscript.
- **Methods to avoid Plagiarism is applied by us on every paper, if found guilty, you will be blacklisted by all of our collaborated research groups, your institution will be informed for this and strict legal actions will be taken immediately.)**
- To guard yourself and others from possible illegal use please do not permit anyone right to use to your paper and files.



CRITERION FOR GRADING A RESEARCH PAPER (COMPILATION)  
BY GLOBAL JOURNALS INC. (US)

Please note that following table is only a Grading of "Paper Compilation" and not on "Performed/Stated Research" whose grading solely depends on Individual Assigned Peer Reviewer and Editorial Board Member. These can be available only on request and after decision of Paper. This report will be the property of Global Journals Inc. (US).

Topics	Grades		
	A-B	C-D	E-F
<i>Abstract</i>	Clear and concise with appropriate content, Correct format. 200 words or below	Unclear summary and no specific data, Incorrect form  Above 200 words	No specific data with ambiguous information  Above 250 words
<i>Introduction</i>	Containing all background details with clear goal and appropriate details, flow specification, no grammar and spelling mistake, well organized sentence and paragraph, reference cited	Unclear and confusing data, appropriate format, grammar and spelling errors with unorganized matter	Out of place depth and content, hazy format
<i>Methods and Procedures</i>	Clear and to the point with well arranged paragraph, precision and accuracy of facts and figures, well organized subheads	Difficult to comprehend with embarrassed text, too much explanation but completed	Incorrect and unorganized structure with hazy meaning
<i>Result</i>	Well organized, Clear and specific, Correct units with precision, correct data, well structuring of paragraph, no grammar and spelling mistake	Complete and embarrassed text, difficult to comprehend	Irregular format with wrong facts and figures
<i>Discussion</i>	Well organized, meaningful specification, sound conclusion, logical and concise explanation, highly structured paragraph reference cited	Wordy, unclear conclusion, spurious	Conclusion is not cited, unorganized, difficult to comprehend
<i>References</i>	Complete and correct format, well organized	Beside the point, Incomplete	Wrong format and structuring



# INDEX

---

---

## **A**

Adiabatic · 48, 71, 73, 74, 76  
Apastrons, · 56

---

## **C**

Copernicus · 4, 7, 16, 18, 94

---

## **G**

Grotesque · 2

---

## **I**

Ignition · 47, 48, 49  
Inimical · 33

---

## **J**

Javelins · 93

---

## **M**

Mediocre · 17  
Monistic · 2, 8

---

## **P**

Primordial · 19, 36  
Ptolemaic · 1, 4, 5, 6, 7, 17, 18  
Pulsating · 10



save our planet



# Global Journal of Science Frontier Research

Visit us on the Web at [www.GlobalJournals.org](http://www.GlobalJournals.org) | [www.JournalofScience.org](http://www.JournalofScience.org)  
or email us at [helpdesk@globaljournals.org](mailto:helpdesk@globaljournals.org)

ISSN 9755896

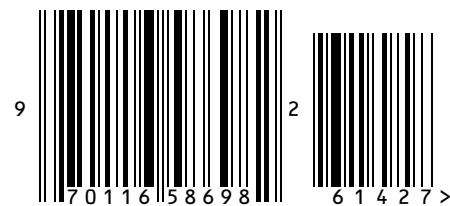

© Global Journals